

STRUCTURE OF THE MICROCARD

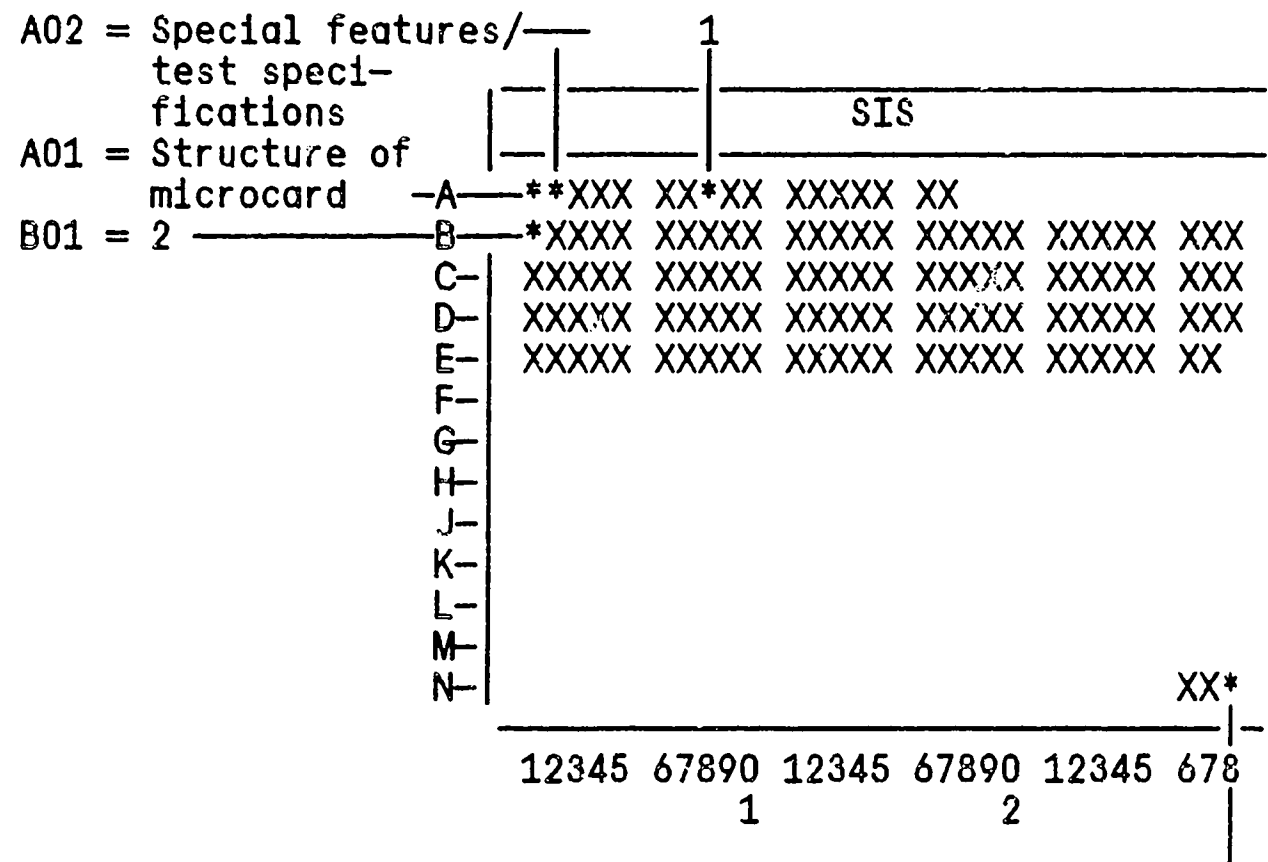

N28 = Table of contents and publication information

- 1 = Tools and devices
- 2 = Complete instructions, divided into test steps (no references)

- a. Read from left to right.
- b. Title of micropicture (appears on each coordinate).

E16	Product/component/test step	
-----	-----------------------------	--

Coordinate

- c. Limits of section

Beginning

Mid-section

End

One-page section

A01		
-----	--	--

SPECIAL FEATURES

These test instructions apply to RSF governors with:

- * Ambient-pressure-dependent full-load stop (ADA)
- * Absolute boost-pressure-dependent full-load stop (ALDA)
- * Start-of-delivery sensor system (FBG)
- * Pneumatic idle increase (PLA)
- * Electronic idle-speed regulation (ELR)
- * Rack position sensor (RWG)
- * Active surge damping (ARD)
- * Positive/negative torque control

TEST SPECIFICATIONS

Idle stage, static M/RSF with and without start-of-delivery sensor system

- * Sliding-sleeve pre-travel (mm), refer to test-specification sheet

If no static data are given on the corresponding test-specification sheet, the following applies to M/RSF with no start-of-delivery sensor system

- * at $n = 1000 \text{ min}^{-1}$, control-rod travel = 1.9...2.0 mm

M/RSF with start-of-delivery sensor system

- * Refer to section on position of idle control lever on test-specification sheet

ADJUSTMENT DIMENSION FOR IDLE AUXILIARY SPRING SHUTOFF (POPPET SHUTOFF)

Basic dimension 1.60...1.65 mm with control lever 47° (add 0.13 mm for every change in control lever position by one degree) e.g. 49 degrees = 1.86...1.91 mm

M/RSFII with ALDA: 2.90...3.00 mm

M/RSFI:
Up to and including FD 044 2.8...3.2 mm
Up to and including FD 045 2.6...2.7 mm

A02		
-----	--	--

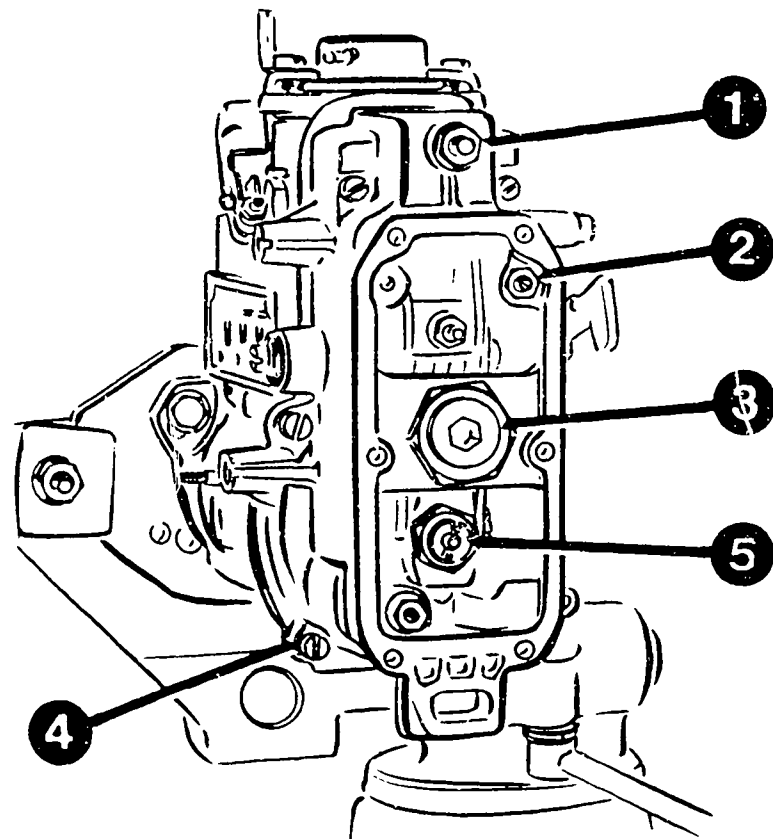

KMK 00922

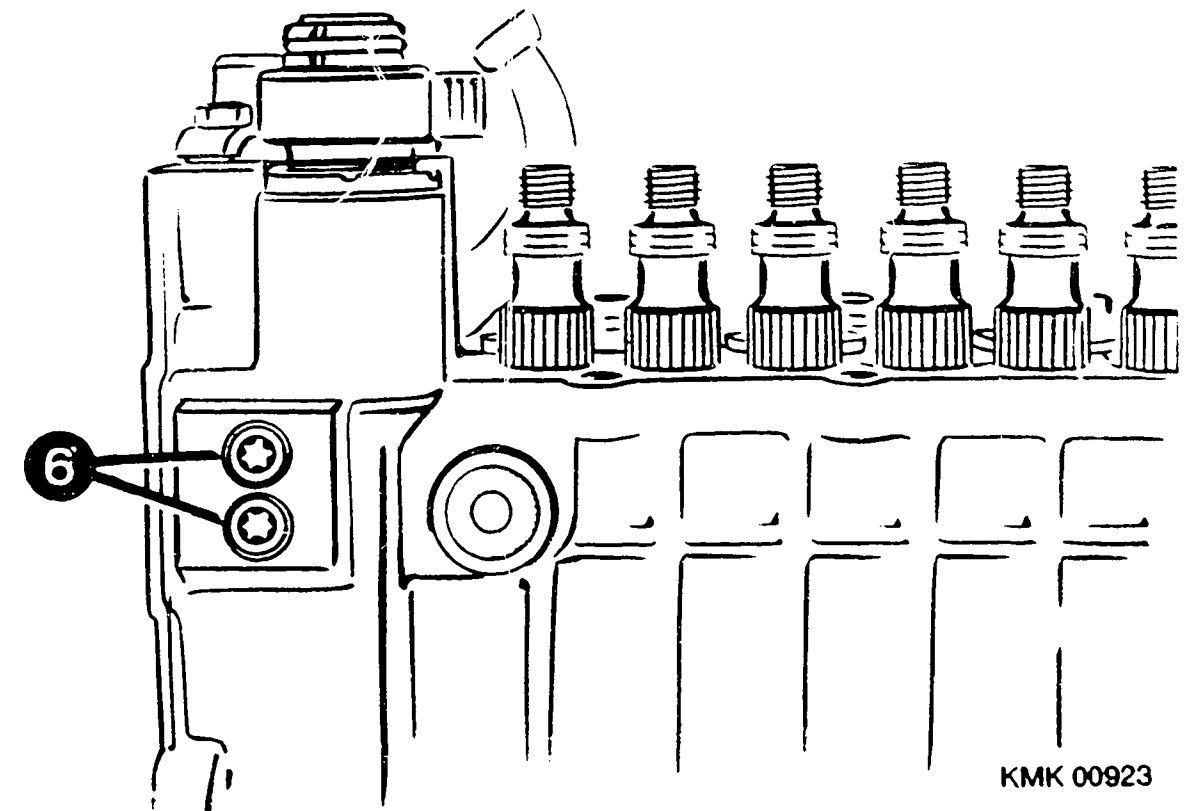

KMK 00923

TIGHTENING TORQUES

The drawings on the following Coordinates contain references for screws, nuts etc. to the subsequent torque-value lists.

TIGHTENING TORQUES

Item No.	Designation	Nm
1	Hexagon nut	17..24
2	Hexagon nut	7...9
3	Hexagon nut	25..45
4	Fillister-head screw	3...5
5	Hexagon nut	15..30

Item No.	Designation	Nm
6	Torx fillister-head screw	7...10

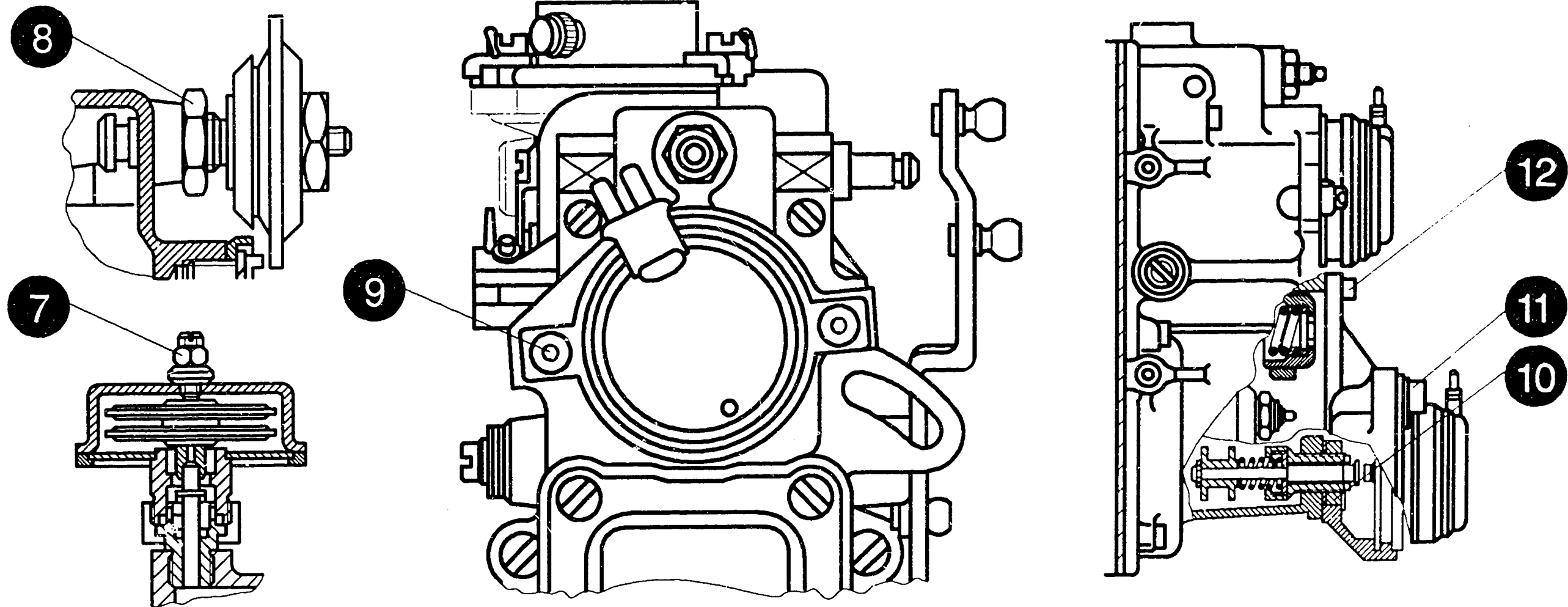

KMK00924

Item No.	Designation	Nm
7	Lock nut	7...10
8	Lock nut	20..40
9	Torx fillister-head screw	10..13

Item No.	Designation	Nm
10	Hexagon nut	35..40
11	Torx fillister-head screw	6...9
12	Torx fillister-head screw	7...9

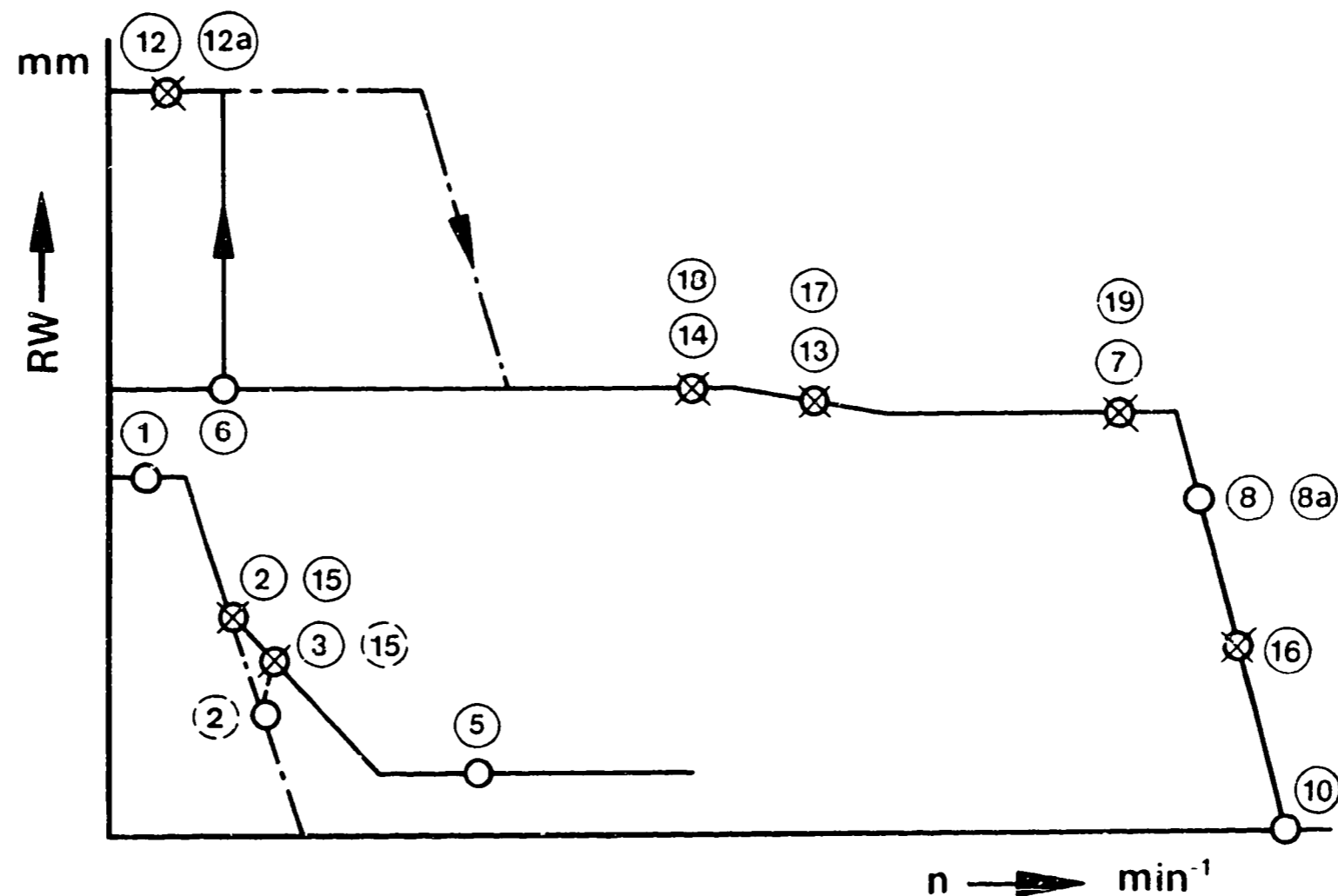

KMK 00925

Governor map

The numbers given in the governor map correspond to the test items of the respective test-specification sheet (not EDP-adapted) in the test-specification microcard for injection-pump equipment.

- RW = Control-rod travel
- n = Fuel-injection-pump speed
- O = Control-rod-travel measurement points
- X = Quantity-injected measurement point

- | | | |
|----------------------------------------|-------------------------------------------|-----------------------------------|
| 1 = Load take-up | 8 = Cont.-rod travel, full-load sp. reg. | 14 = Full-load control-rod travel |
| 2 = Idle control-rod travel | 8a = Delivery, full-load speed regulation | 15 = Low idle quantity |
| 3 = Idle auxiliary spring | 10 = Sliding-sleeve-position test point | 16 = High idle quantity |
| 5 = Unregulated stage | 12 = Starting control-rod travel | 17 = Torque-control quantity |
| 6 = Switching point | 12a = Starting fuel delivery | 18 = Full-load-quantity point |
| 7 = Upper full-load control-rod travel | 13 = Torque-control control-rod travel | 19 = Upper full-load quantity |

INSTRUCTIONS ON TESTING GOVERNORS

General instructions

The test instructions contain all the necessary data and information required for adjusting governors of type RSF. Further details concerning:

- Test equipment and pump test bench
- Calibrating oil

are given in the instructions W 400/0. . .

The sequence of operations described corresponds to the sequence used in the test specifications.

The stated deliveries in each case represent the average value of all plunger-and-barrel assemblies of a fuel-injection pump. The prescribed delivery difference applies to the individual plunger-and-barrel assemblies of a pump.

Prescribed control-rod travels are set and measured with the corresponding control-rod-travel measuring device. Check values for speeds, deliveries and difference are given in brackets.

They apply only in the initial condition of an injection-pump assembly and are **n e v e r** to be used for re-adjustment.

Test specifications

The test specifications for fuel-injection equipment are contained in the test specifications of the microcard WP. . .

Item numbers:

Item numbers used in the text do NOT correspond to the item numbers in the service-parts list.

Note on test specifications:

Testing of the governor necessitates a test-specification microcard which is to be inserted in the second reader slide.

Notes on delivery testing and adjustment:

Testing and adjustment of the governor presupposes that the corresponding fuel-injection pump is in proper mechanical working order and already hydraulically correct in line with test-specification sheet SECTION A - old test-specification sheet or BASIC SETTING - EDP test-specification sheet.

The delivery difference (scatter) outlined in Section A likewise applies - converted to 1000 stroke measurement - to full-load quantity scatter.

Notes on functional test and adjustment:

If the governor is merely checked as to its mechanical serviceability WITHOUT prior REPAIR, it remains fully assembled on the fuel-injection pump. Governor and pump are then installed and checked as a unit on the injection-pump test bench.

If, on the other hand, the governor is NEWLY adjusted and tested FOLLOWING repair, it is installed without closing cover on the fuel-injection pump which is already on the injection-pump test bench.

SAFETY PRECAUTIONS

- Check screw connections of test-pressure lines for leaks (visual inspection).
- Replace damaged lines (kinked, leaking soldered joints, damaged sealing surfaces).
- Make use of the tools, drive components and holding parts prescribed in these instructions.
- Never lean over turning parts (drive coupling, inertia flywheel).
- Before operating fuel-injection pump, ensure that parts cannot be flung out by rotation of injection-pump drive (tommy for inertia flywheel, tools etc.).
- Remove spilt calibrating oil immediately to eliminate danger of slipping. Dispose of calibrating oil and binder.
- The noise level at the test bench may exceed 90 dB(A) during test operation. Protection for the ears is to be worn during test operation.
- Protective goggles are to be worn during test operation.
- Make exclusive use of calibrating oil as per ISO 4113.

Safety precautions (continued)

- Do not apply voltage to injection-pump components (e.g. servo magnet (ELR) supplied with D.C. voltage until component has been connected up. The same sequence applies to disconnection.
- When attaching drive coupling or other drive elements to inertia flywheel of drive, use prescribed torque for tightening the fastening screws. The same applies to the clamping jaws of the drive coupling.
- Test bench may only be operated with drive coupling attached if a test specimen is flanged on.
- Drive coupling must be covered with guard during operation.
- Prior to every test run, all assembly tools are to be removed from fuel-injection pump, clamping bed and coupling area.
- Fuel-injection pumps with damaged housings are not to be tested.
- The test specimen is only to be tested in the prescribed direction of rotation and at the prescribed maximum speed.
- Leak-fuel-free calibrating nozzle-holder assemblies are only to be used on fuel-injection pumps with constant-pressure valves.
- Install test-pressure lines perpendicularly on pipe connections and calibrating nozzle-holder assemblies.

- Safety precautions when handling combustible liquids:
Order Governing Work with Combustible Liquids (Vbf)
as issued by Federal Labor Ministry (BmA).
Safety regulations for handling chlorinated hydrocarbons
 - for companies ZH 1/222
 - for employees ZH 1/129as published by Hauptverband für gewerbliche Berufsgenossenschaften (Zentralverband für Unfallschutz und Arbeitsmedizin), Langwartweg 103, 5300 Bonn 5, Germany. The corresponding local regulations are to be heeded in other countries.

Test conditions

In order to attain the prescribed values for pump adjustment or pump checking, precise attention is to be paid to the test conditions listed on the test-specification sheet, particularly as regards inlet pressure and, if stated, a special overflow valve for suction-chamber flushing.

Delivery measurement

- * Moisten insides of graduates before taking any measurements. To do so, allow calibrating oil to run in and graduates to drip off for 30+/-1 seconds.
- * Following completion of each measurement, allow graduates to drain off for 30+/- 1 seconds before commencing new measurement. Wet graduates again if interval after draining-off is longer than 10 minutes.
- * Keep test temperature constant within stated tolerances whilst measuring pump.

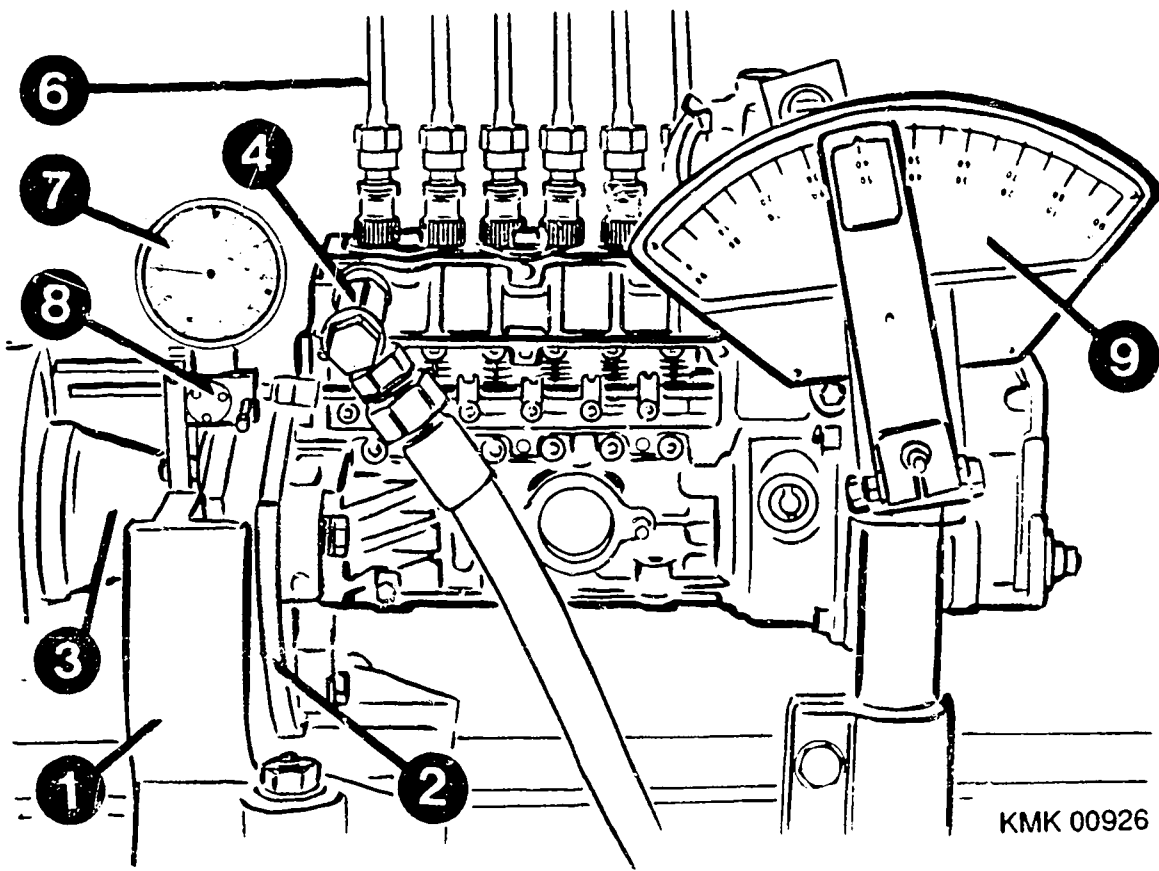

TEST SET-UP

Item	Designation	Part no.
1	Universal clamping bracket	1 688 010 010
2	Clamping flange	1 685 720 208
3	Coupling half M/RSFII	1 686 432 019
4	Fitting	1 683 457 081
5	Calibrating nozzle-holder assembly * e.g. (not visible in picture)	0 681 343 009
6	Test-pressure line 6 X 2 X 600 mm	1 680 750 014
7	Dial indicator	1 687 233 015
8	Measuring device	1 688 130 130
9	Protractor	0 681 440 006 1 688 130 183

* Compare test equipment to test-specification sheet.

TOOLS AND TEST EQUIPMENT

Tools Test equipment	Type desig./ part no.	Application
Measuring device with accessories	1 688 130 130	Measuring control-rod travel
Dial indicator	1 687 233 015	Measuring control-rod travel
Protractor	0 681 440 006 or 1 688 130 183	Setting control-lever angle
Clamping flange	1 685 720 208 or 1 685 720 018	Pilot diameter 77 mm Pilot diameter 68 mm
Coupling half Taper 17 mm or Coupling half with serrations	1 416 430 012 1 686 432 019	Operation of injection pump on test bench
Support clamp	1 688 040 221	Dial-indicator mount
Testing device	1 688 130 075	Vacuum testing

Continued Tools Test equipment	Type desig./ part no.	Application
Pin-type socket wrench	KDEP 2968	Adjusting spring retainer
Puller half	KDEP 2886	Removal of flyweights
Pin-type socket wrench	KDEP 2919	Removing fastening nut of flyweight
Extractor	KDEP 1573	Removing ELR servo magnet
Embossing tool	KDEP 1635	Control-rod closure cap
Ball-type Torx wrench	Commercially available	
Clamping device	KDEP 1545	Fixing control rod
Test cone -Governor with no FBG	KDEP 1045	Leak test Camshaft chamber
Test cone -Governor with FBG	KDEP 1565	

Continued Tools Test equipment	Type desig./ part no.	Application
Pressure- reducing valve with pressure gauge 0...4 hPa	Commercially available	Gauge- pressure testing
Pressure gauge 0...1.6 hPa Quality class 1.0 Scale divisions 0.05	Commercially available	Vacuum testing

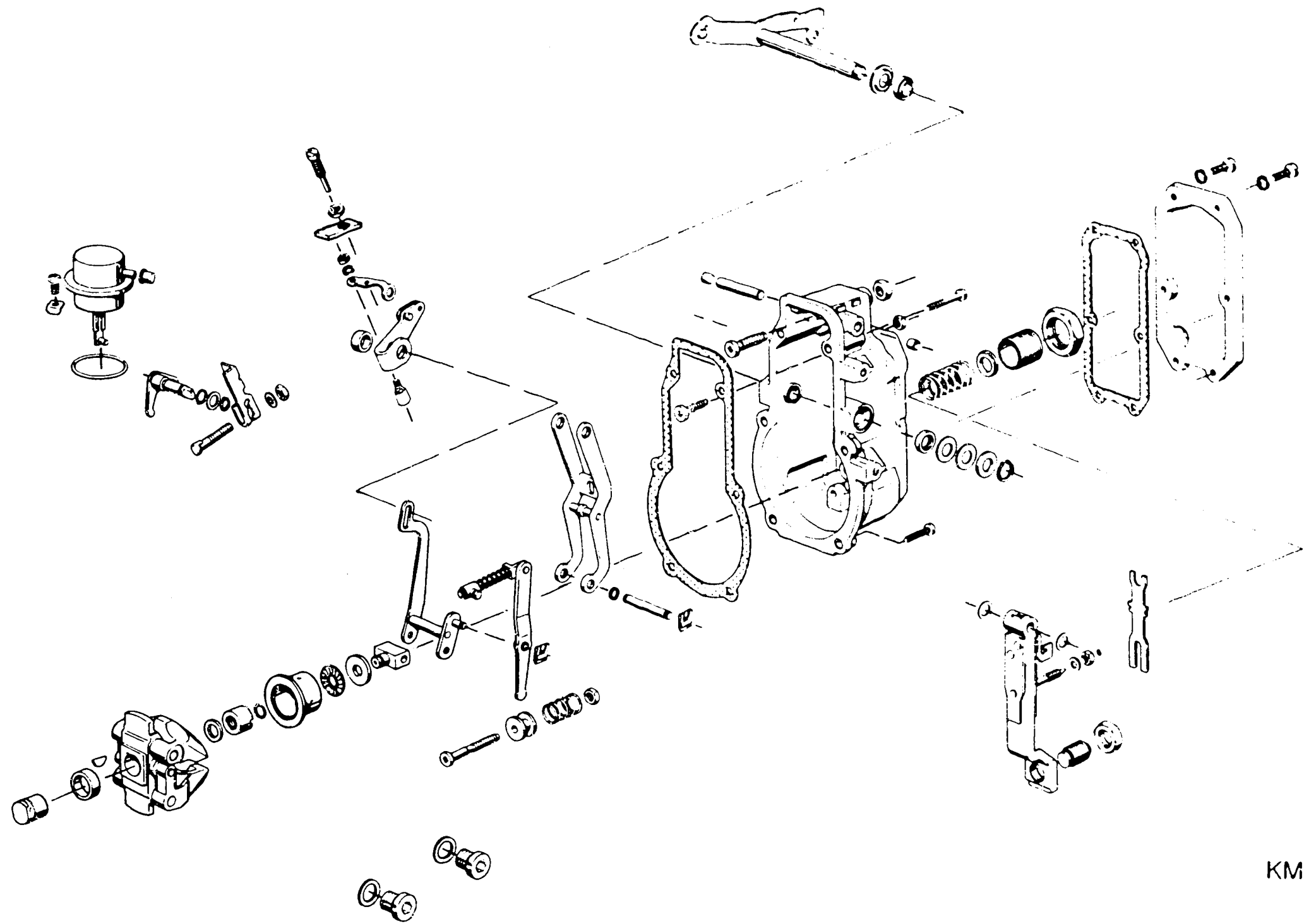

KMK 00927

EXPLODED VIEW

* RSF I governor

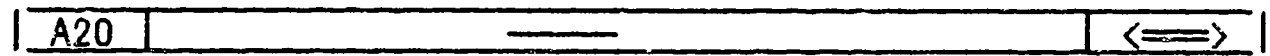
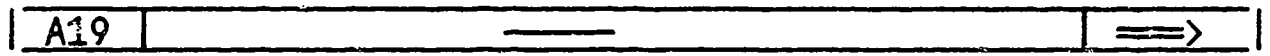

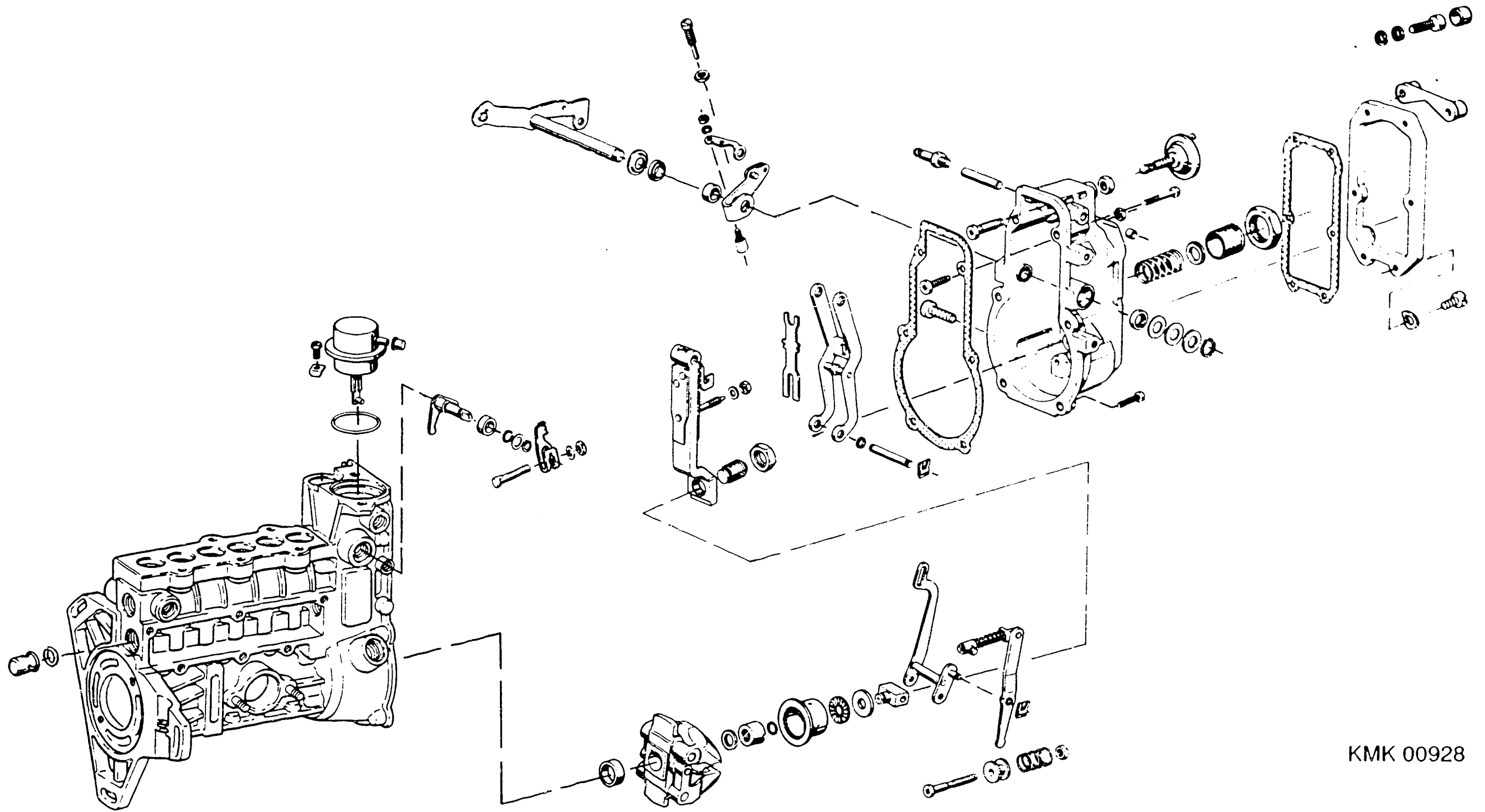

KMK 00928

EXPLODED VIEW OF RSF II GOVERNOR

Special features:

- Vacuum unit for pneumatic idle increase (PIA)

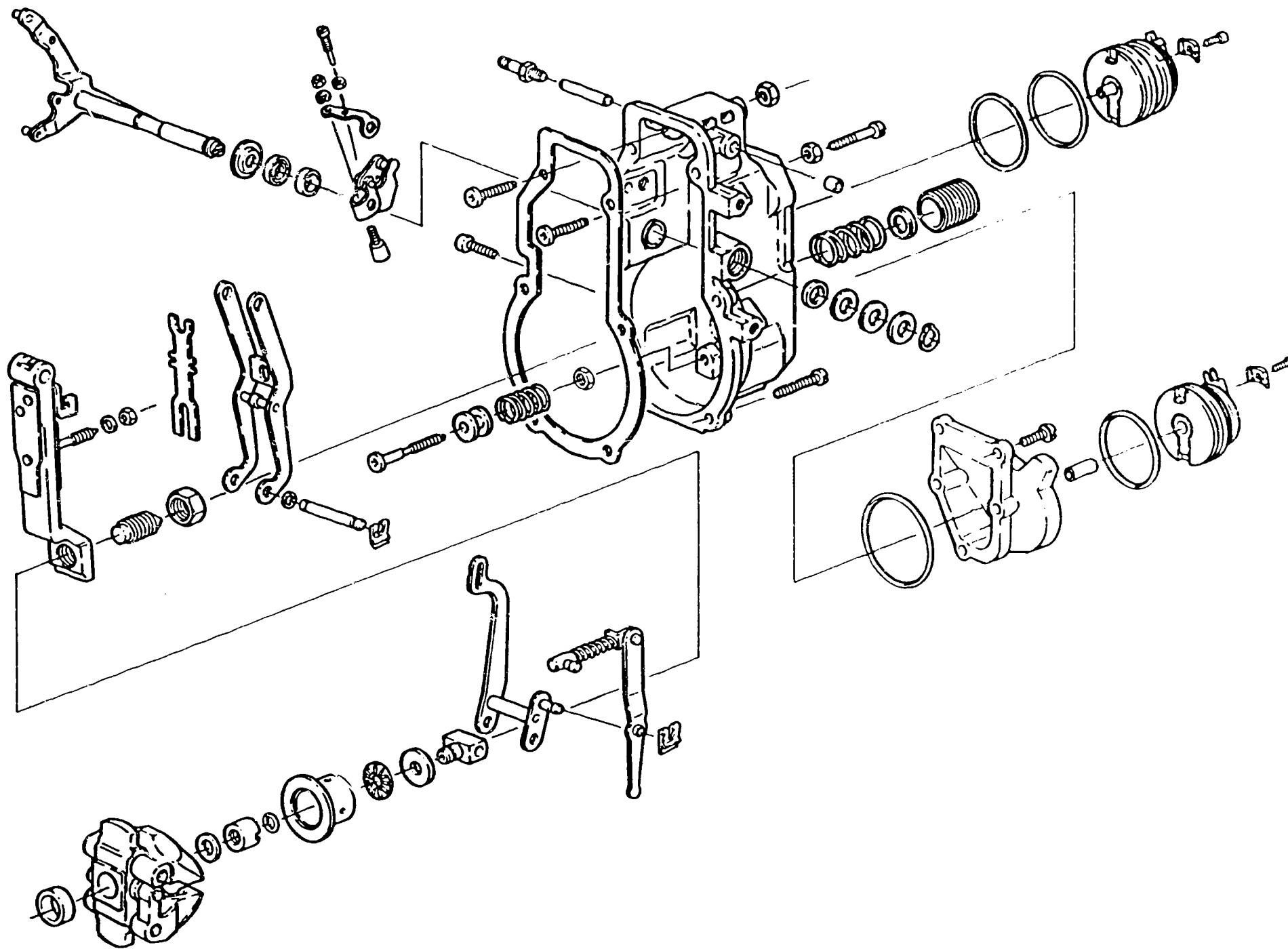

KMK 00929

EXPLODED VIEW OF RSF II GOVERNOR

Special features:

- Servo magnet for electronic idle-speed regulation (ELR)
- Servo magnet for active surge damping (ARD)

A23



A24



TROUBLE-SHOOTING CHART FOR PARTIAL-REPAIR SECTION

If there is no customer complaint or fault characteristic, it is advisable to perform an incoming inspection on the test bench.

Customer complaint (fault characteristic)

- 1. Control rod sticking
- 2. Engine does not shut off or only hesitantly
- 3. Engine doesn't start when cold or only with difficulty
- 4. Bucking whilst driving with pumps M/RSF I
- 5. Transverse vibration at idle
- 6. Engine cuts out after lengthy motorway run

					Cause of problem	Coordinates
*					Check position of control sleeves	B03
*					Renew shutoff stop screw	B04
*					Check freedom of movement of shorting ring of rack position sensor	B05
*					Check vacuum unit	B06
	*				Check pneumatic/electr. idle increase	B07
		*			Renew idle auxiliary spring	B08
			*		Check idle-quantity scatter	B10
				*	Renew flyweight	B11

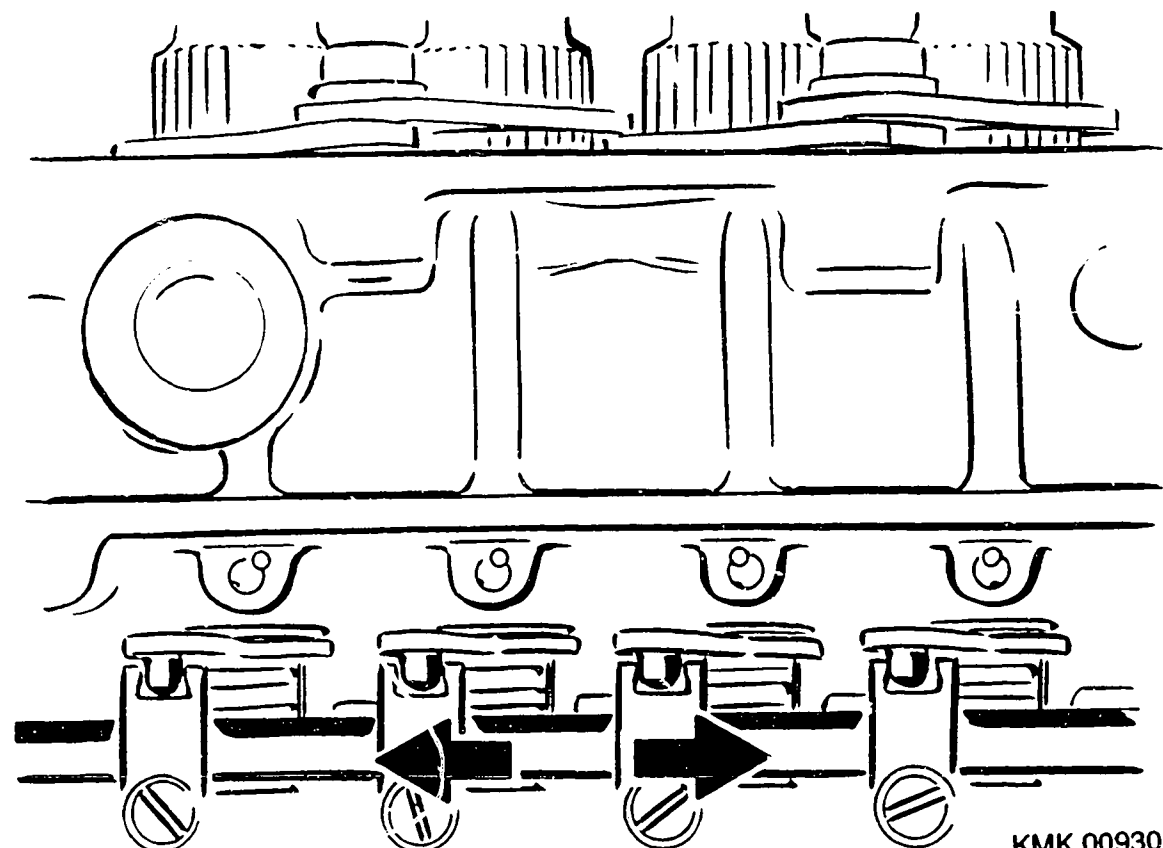

KMK 00930

PARTIAL REPAIR

CHECKING POSITION OF CONTROL SLEEVES

Remove spring-chamber closing cover.

Check control rod for freedom of movement and equal left/right stop.

In control-rod positions "start and shutoff" ensure that linkage levers do not become disengaged or catch on upper spring seat/tappet spring.

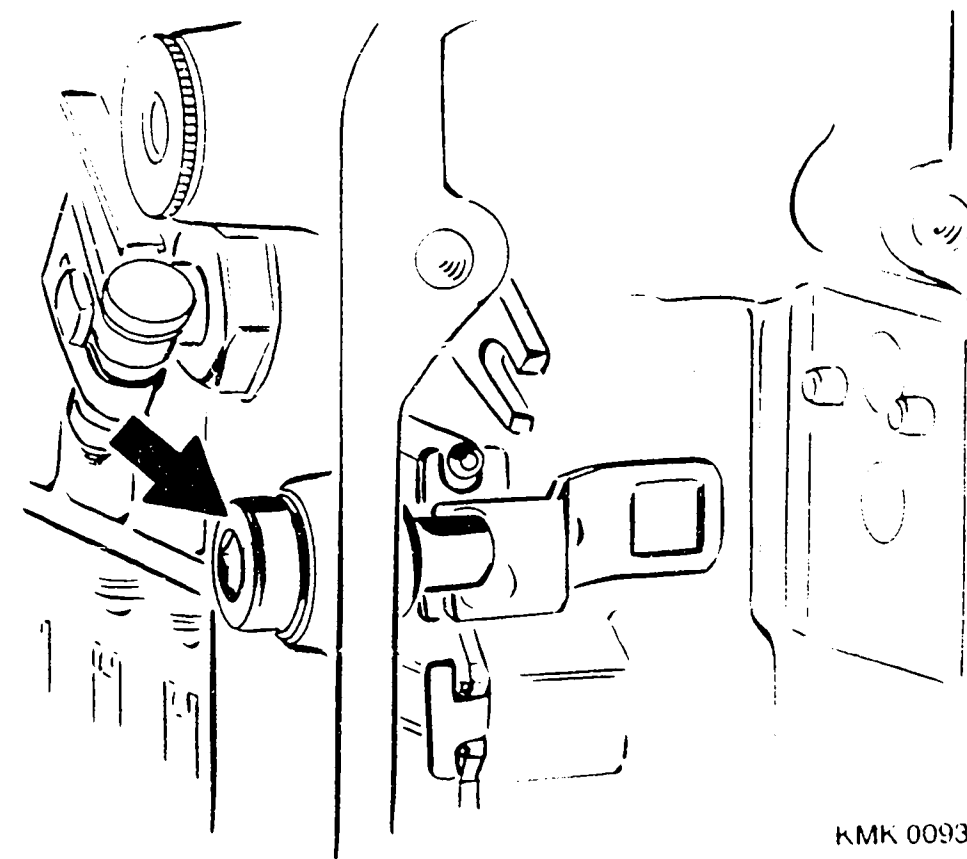

KMK 00931

Arrow = Shutoff stop screw

RENEWING SHUTOFF STOP SCREW

There is a new shutoff stop screw with larger pin diameter as of FD 449

Replacement of shutoff stop screw prior to FD 449 without re-adjustment of pump:

- Screw out old shutoff stop screw.
- Screw in new shutoff stop screw 1 413 414 010. (Characteristic feature: white chromium-plated instead of yellow)

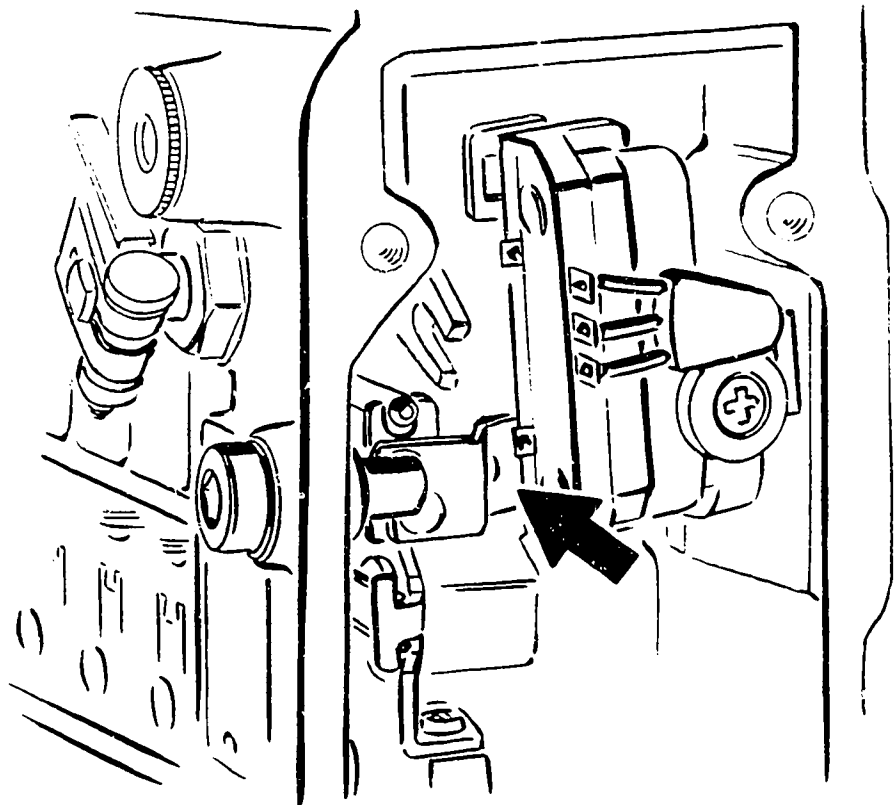

KMK 00932

CHECKING FREEDOM OF MOVEMENT OF SHORTING RING OF RACK POSITION SENSOR

In the adjustment range (control-rod travel 0 - 21 mm), the shorting ring (arrow) must glide past the long arm of the rack position sensor without making contact.

Note:
Pay attention to tilt clearance of control rod.

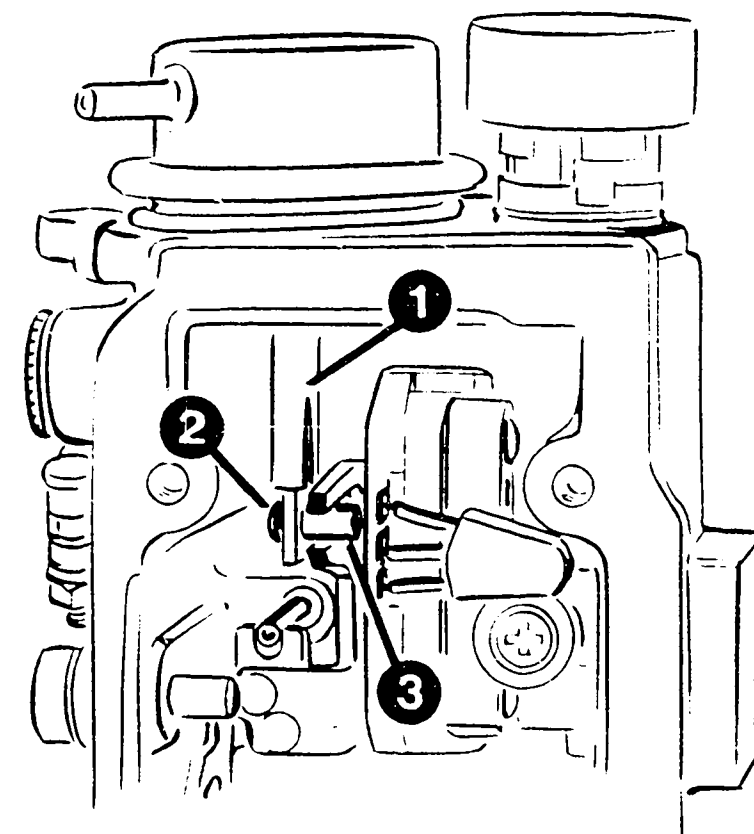

KMK 00933

- 1 = Guide rails
- 2 = Rivet head
- 3 = Drive hub

CHECKING VACUUM UNIT

Possible cause of fault: Defective shutoff unit, i.e. unevenly bent guide rails or excessively large rivet head.

Mechanical testing:
Exert force on side of drive hub. Connecting rod must nevertheless slide smoothly in guide rail.

Leak test:
Apply 500 hPa vacuum to vacuum unit (using for example Mityvac pump).
Control rod must be pulled to shutoff stop.

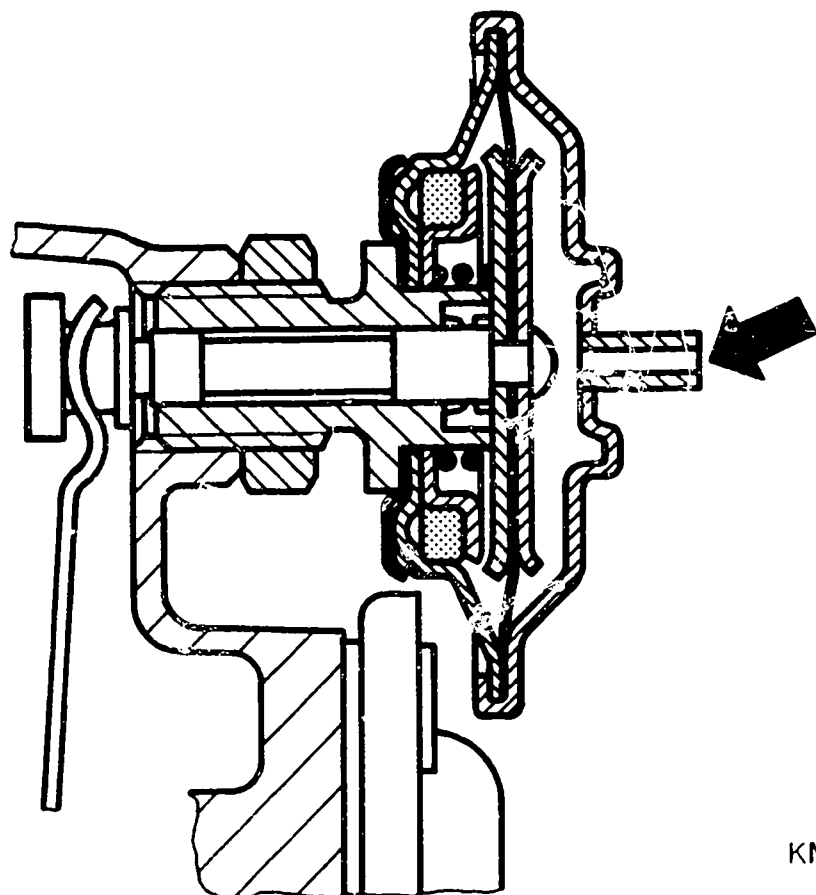

KMK 00934

CHECKING PNEUMATIC IDLE INCREASE (PLA)

Apply 750 hPa vacuum to PLA unit at vacuum connection (arrow) by way of 3-way valve and pressure gauge.

Disconnect vacuum supply from PLA and pressure gauge via 3-way valve.

Permissible drop in pressure 30 hPa in 15 seconds.

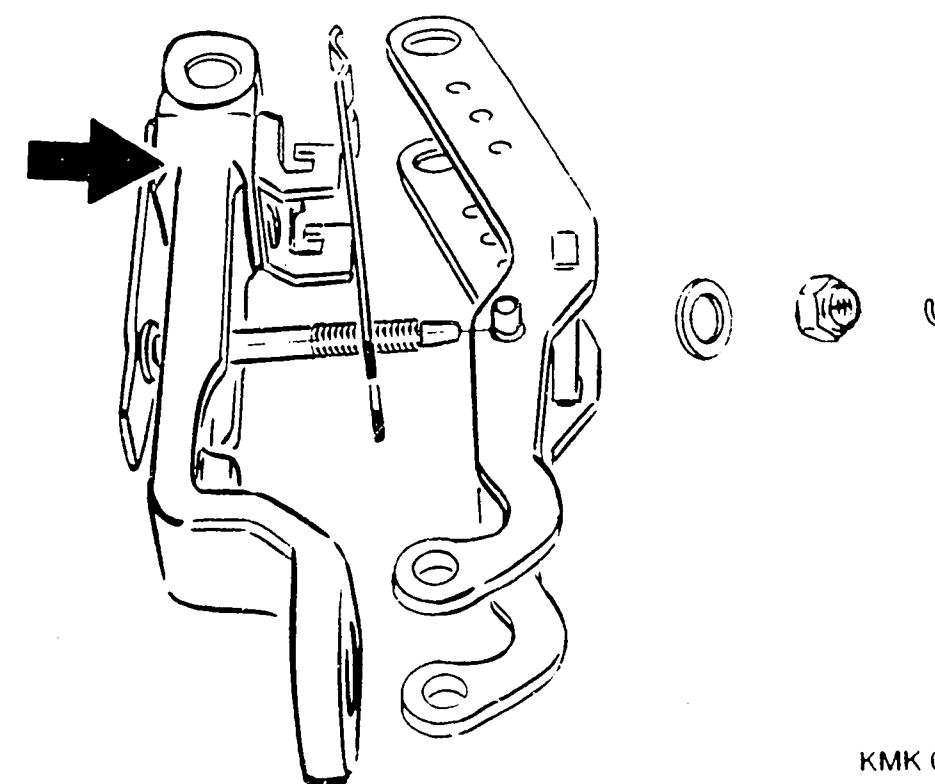

KMK 00935

Arrow = Tensioning lever

RENEWING IDLE AUXILIARY SPRING (POPPET) *(M/RSF with no start-of-delivery sensor system)

Improvement can be achieved by installing a thicker idle auxiliary spring (leaf spring 2.0 instead of 1.5 mm).

- Remove tensioning lever with riveted-on poppet spring as well as adjusting screw.
- Install new tensioning lever with thicker idle auxiliary spring and likewise with larger adjusting screw.
- Following conversion, mark fuel-injection pump with red dot on governor housing (next to pneumatic shutoff unit).

ADJUSTMENT ON PUMP TEST BENCH

Installation of a thicker idle auxiliary spring shifts the speed for the full-load adjustment point

- from $n = 2200 \text{ min}^{-1}$
- to $n = 2100 \text{ min}^{-1}$

and for the idle-control-lever position

- from $n = 1000 \text{ min}^{-1}$
- to $n = 1100 \text{ min}^{-1}$

CHECKING IDLE-QUANTITY SCATTER

A complaint concerning transverse engine vibration may be the result of:

Idle-quantity scatter at pump and engine scatter.

Transverse vibration can be improved in some cases by reducing the idle-quantity scatter to $0.5 \text{ cm}^3 / 1000$ strokes.

RENEWING FLYWEIGHT

Remove flyweight, wash it out and shake it.
Note: Take care not to wash out flyweight bearing.

Hold flyweight link horizontal and induce to-and-fro movement.
Flyweights must move easily.

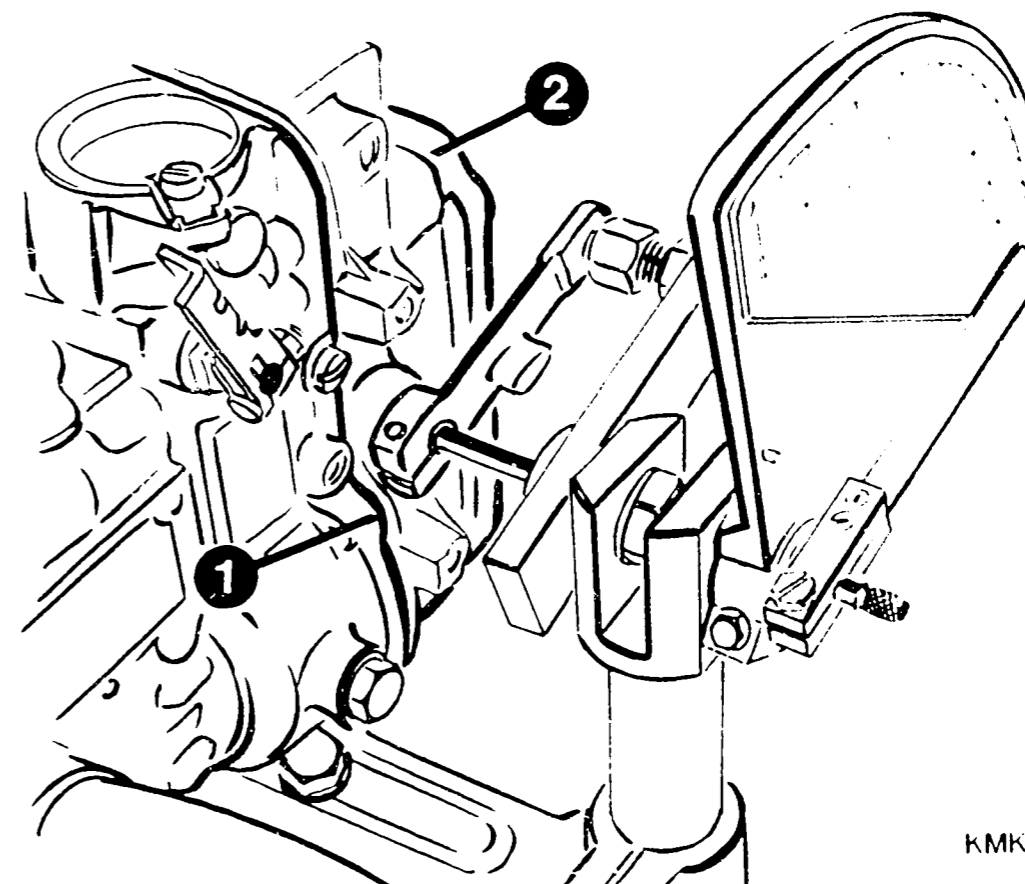

KMK 00936

1 = Seal

2 = Governor cover

ADJUSTING GOVERNOR RSF WITHOUT START-OF-DELIVERY SENSOR SYSTEM (FBG)

- * With FBG as of Coordinate C15
- * With FBG and positive/negative torque control as of Coordinate D24
- * Preparation following pump repair

Add-on modules not attached.
Insert seal between governor cover and pump.
Attach governor with built-in compound lever to fuel-injection pump.
Do not fit governor closing cover.

Attach protractor to control lever such that there is no stress.
Depending on type of test bench, fit auxiliary lever (control lever of RQV governor) if appropriate on opposite side of governor control lever.

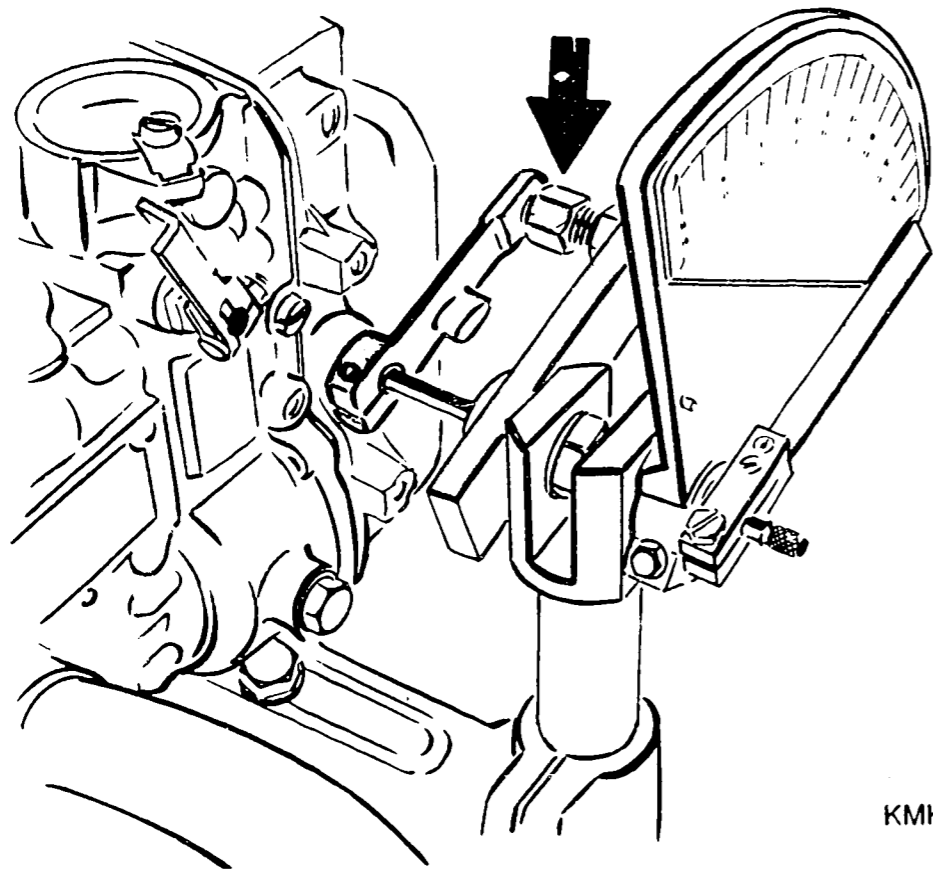

KMK 00960

Attaching swivelling lever to control lever

Pointed pivot of angle indicator must face center of control-lever shaft. The swivel arm of the setting device is attached to the control lever such that there is no stress.

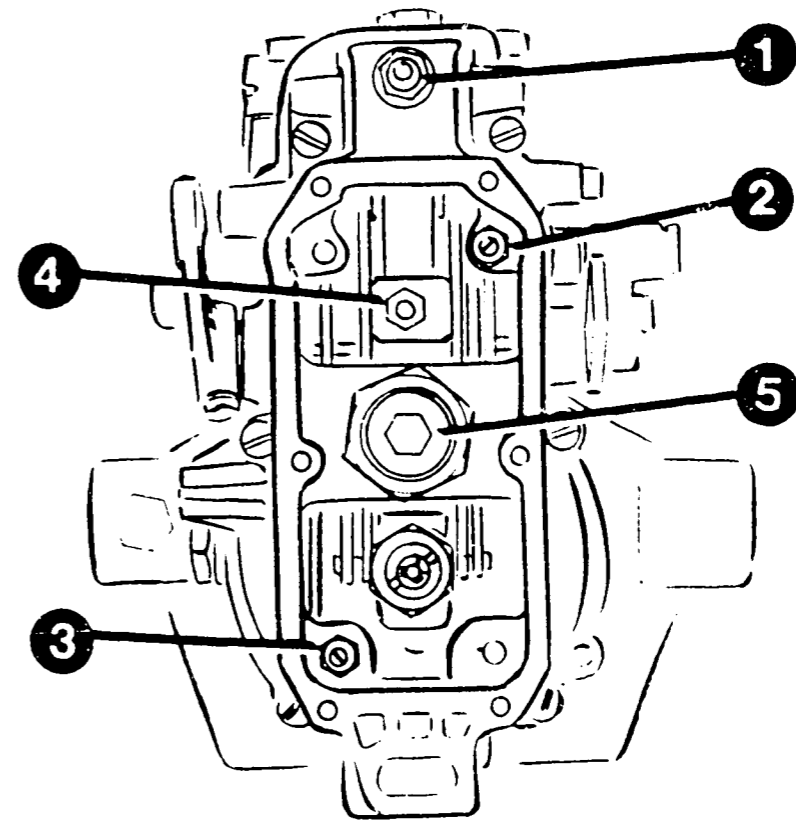

KMK 00937

- 1 = Idle adjusting screw *12.0 mm
- 2 = Idle stop screw * 7.0 mm
- 3 = Adjusting screw for full-load control-rod travel * 6.0 mm

GOVERNOR PRESETTINGS

* Measure distance between stud curvature and hexagon nut.

Note:

If the corresponding test-specification sheet does not indicate the static sliding-sleeve pre-travel, the above governor presettings are to be made. If the sliding-sleeve pre-travel is indicated under "Remarks", all adjusting screws in the governor are to be moved back.

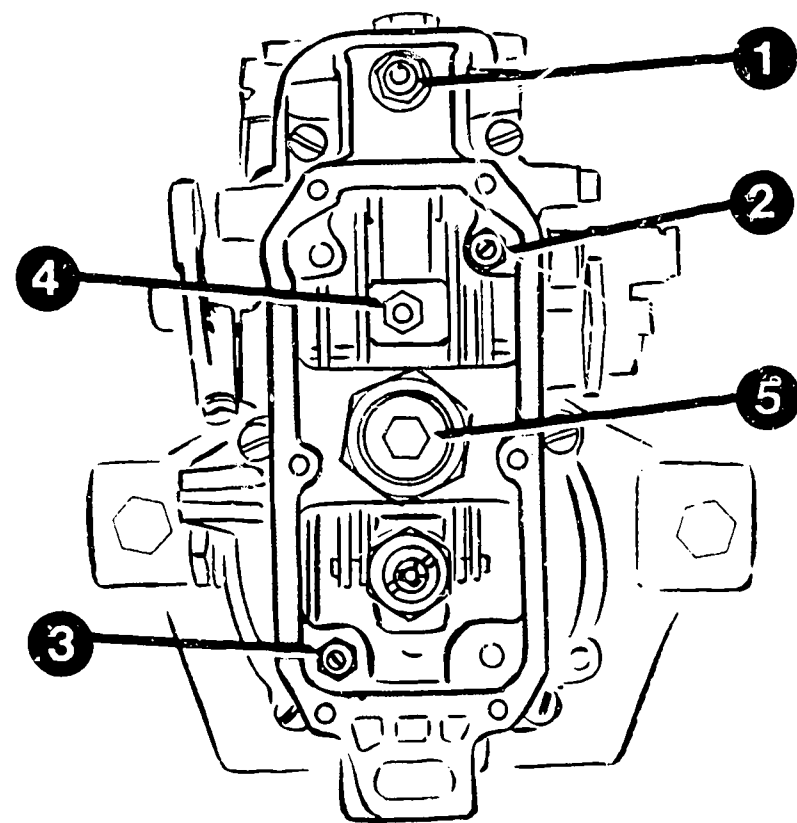

KMK 00937

- 4 = Poppet adjusting nut
- 5 = Threaded sleeve, full-load speed regulation

Screw out poppet adjusting nut as far as retainer (visible at start of thread).

Screw in threaded sleeve, full-load speed regulation until it is flush with hexagon nut.

Pour engine oil into governor and fuel-injection pump (200 cm³ in each case).
Set suction-chamber pressure on test bench to 1 bar.

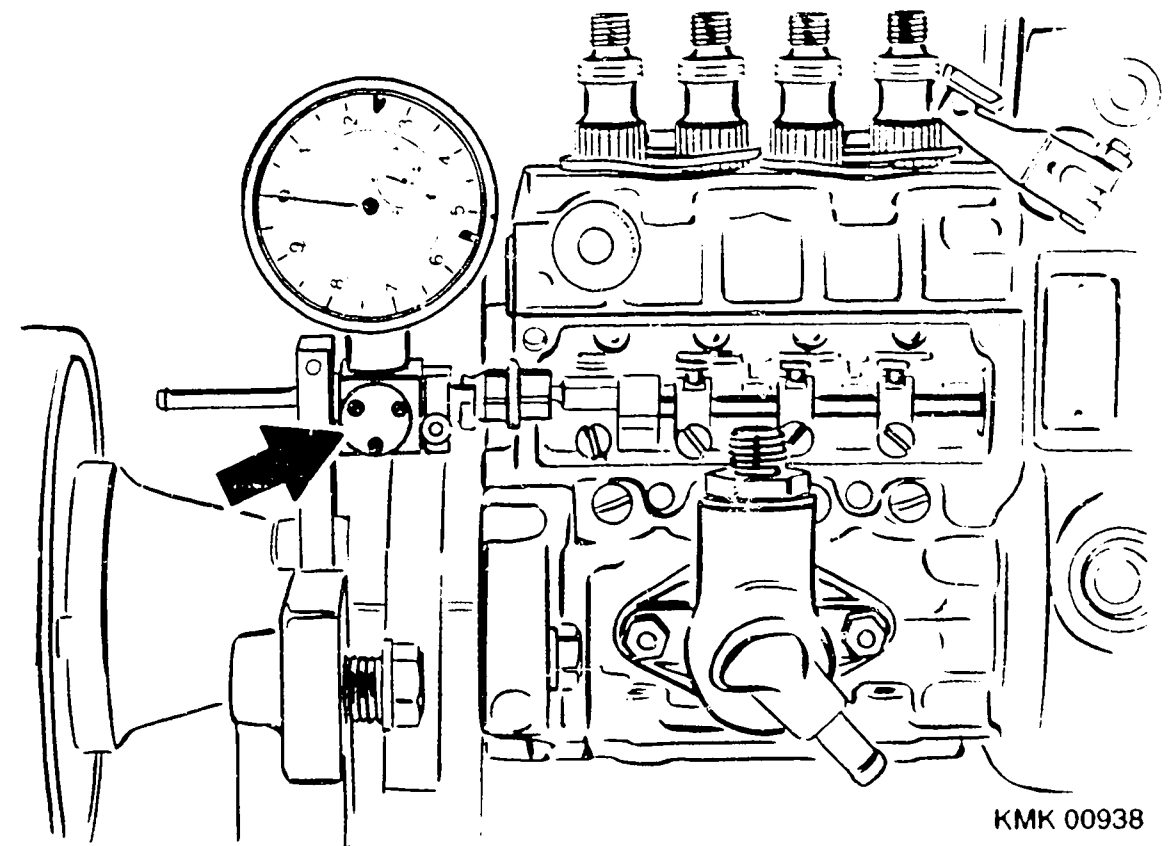

KMK 00938

Arrow = Dial-indicator holder

ADJUSTING CONTROL-ROD-TRAVEL MEASURING DEVICE

Attach control-rod-travel measuring device 1 688 130 130 with accessories.
Set dial-indicator pointer in shutoff position of control rod to "0".

Move control rod from shutoff to full-load stop and check whether pointer of dial indicator shows "0" again in shutoff position.
Set dial-indicator pointer.

In the case of versions WITHOUT thread at control-rod guide bushing, attach support clamp 1 688 040 221.

Position control lever against full-load stop.
Adjust setting device in accordance with test-specification sheet (50°).

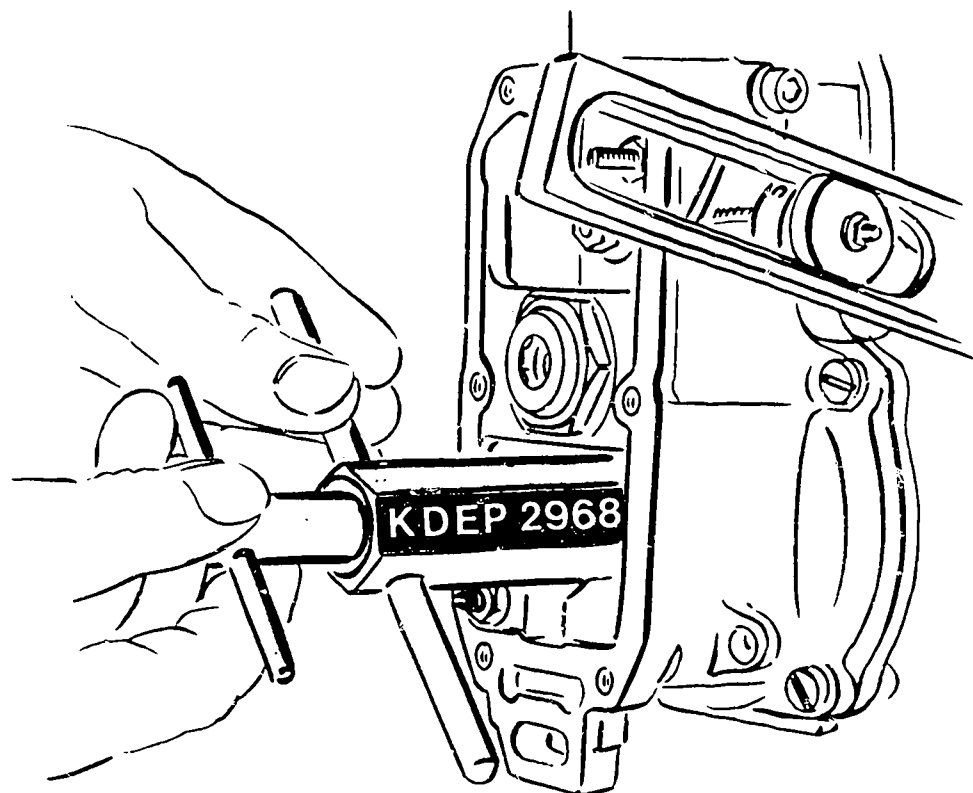

KMK 00961

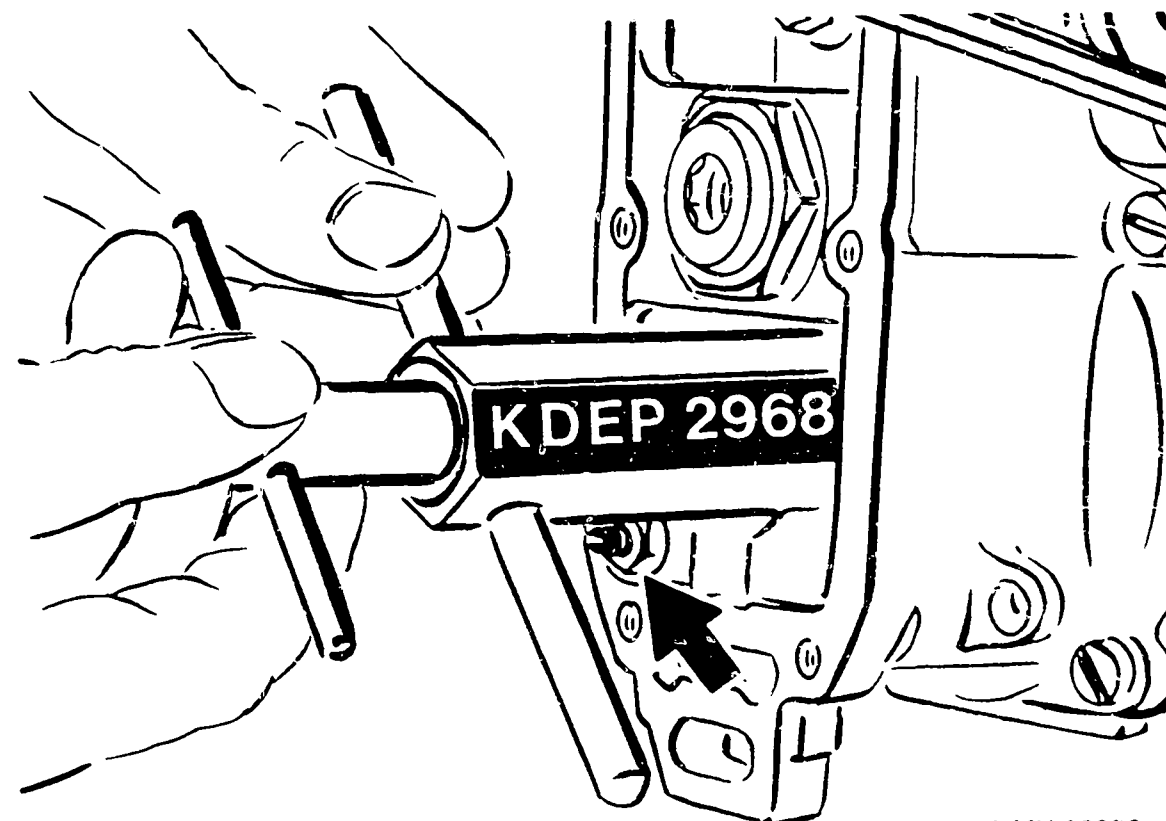

KMK 00939

STATIC IDLE-STAGE ADJUSTMENT

* Refer to back of test-specification sheet for sliding-sleeve pre-travel (mm)

No indication given - continue as of Coordinate B18

Adjust control lever to idle control lever mid-position.

At speed "0", screw in spring retainer (torque-control retainer) with pin-type socket wrench KDEP 2968 until spring retainer makes contact with sliding sleeve.

Take care not to over-compress spring retainer.

Then set sliding-sleeve pre-travel indicated on test-specification sheet by screwing out spring retainer. (1 turn = 1 mm).

Continue as of Coordinate B20

Arrow = Adjusting screw for full-load control-rod travel

DYNAMIC IDLE-STAGE ADJUSTMENT

At speed "0", set control-rod travel of 13.4 mm with control lever.

If control-rod travel of 13.4 mm is not obtained, perform correction at adjusting screw for full-load control-rod travel (arrow).

Fix control lever.

Operate fuel-injection pump at $n = 1000 \text{ min}^{-1}$.
Loosen hexagon nut of spring retainer (torque-control retainer) using pin-type socket wrench KDEP 2968.

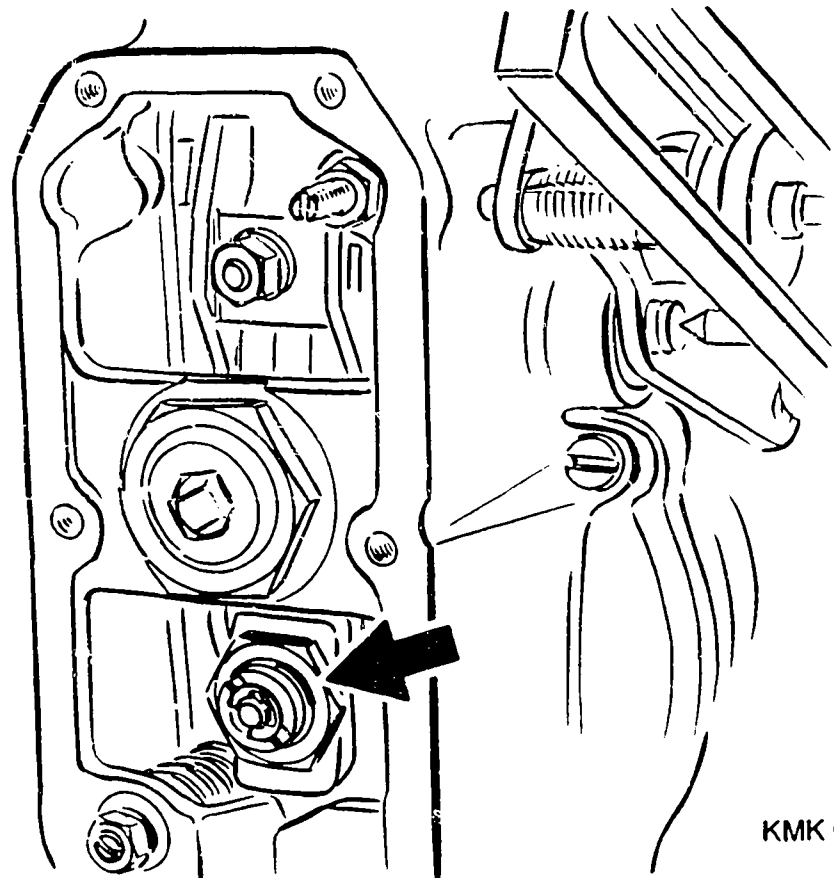

Arrow = Spring retainer

Screw out spring retainer until control-rod travel as per test-specification sheet is attained. Tighten hexagon nut of spring retainer to 30...35 Nm.

Check control-rod travel again.

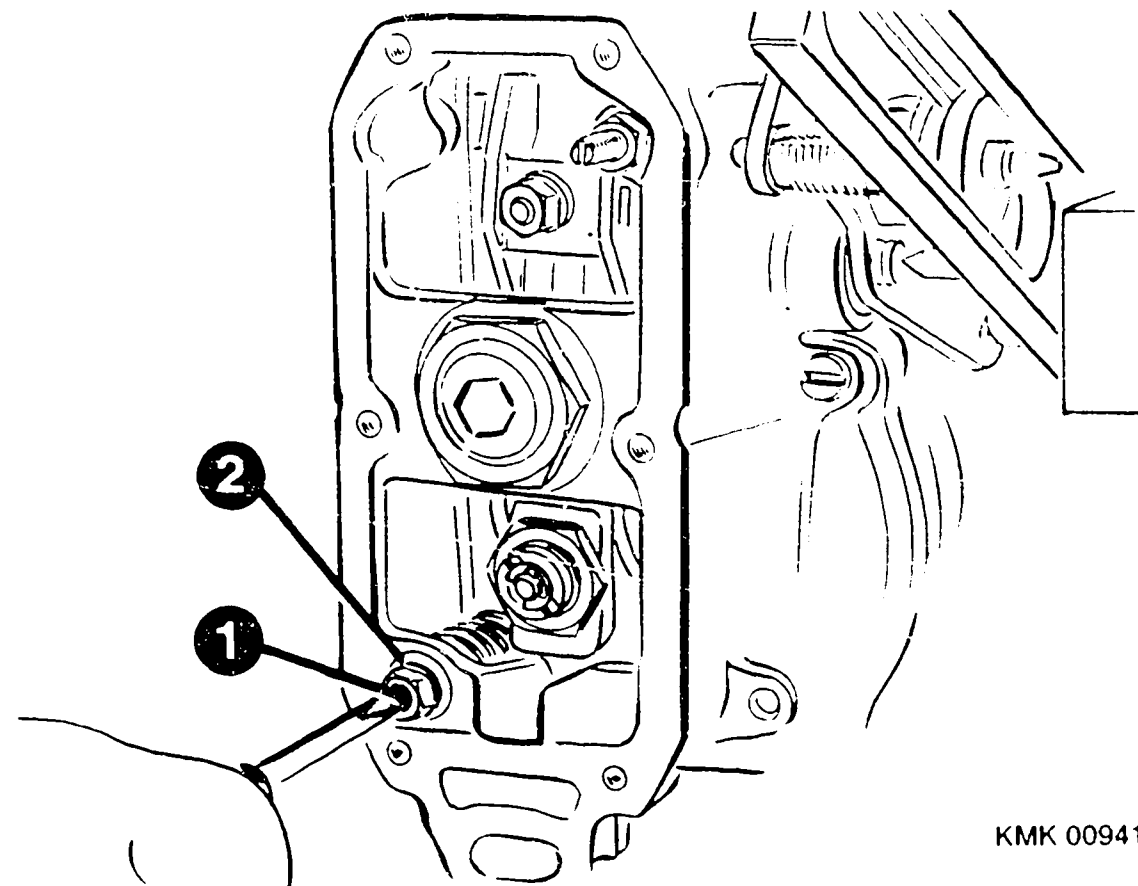

1 = Adjusting screw for full-load control-rod travel
2 = Hexagon nut

ADJUSTING FULL-LOAD CONTROL-ROD TRAVEL AND MEASURING DELIVERY

Loosen control lever and position against full-load stop (head of hexagon-socket-head cap screw on governor-control-lever side)

Operate fuel-injection pump at prescribed speed as per Section B, Item 14. Adjust full-load control-rod travel by means of guide pin. Tighten hexagon nut to 5...7 Nm.

Check delivery as per Section C, Item 18.

If delivery is not obtained, correct control-rod travel within tolerance.

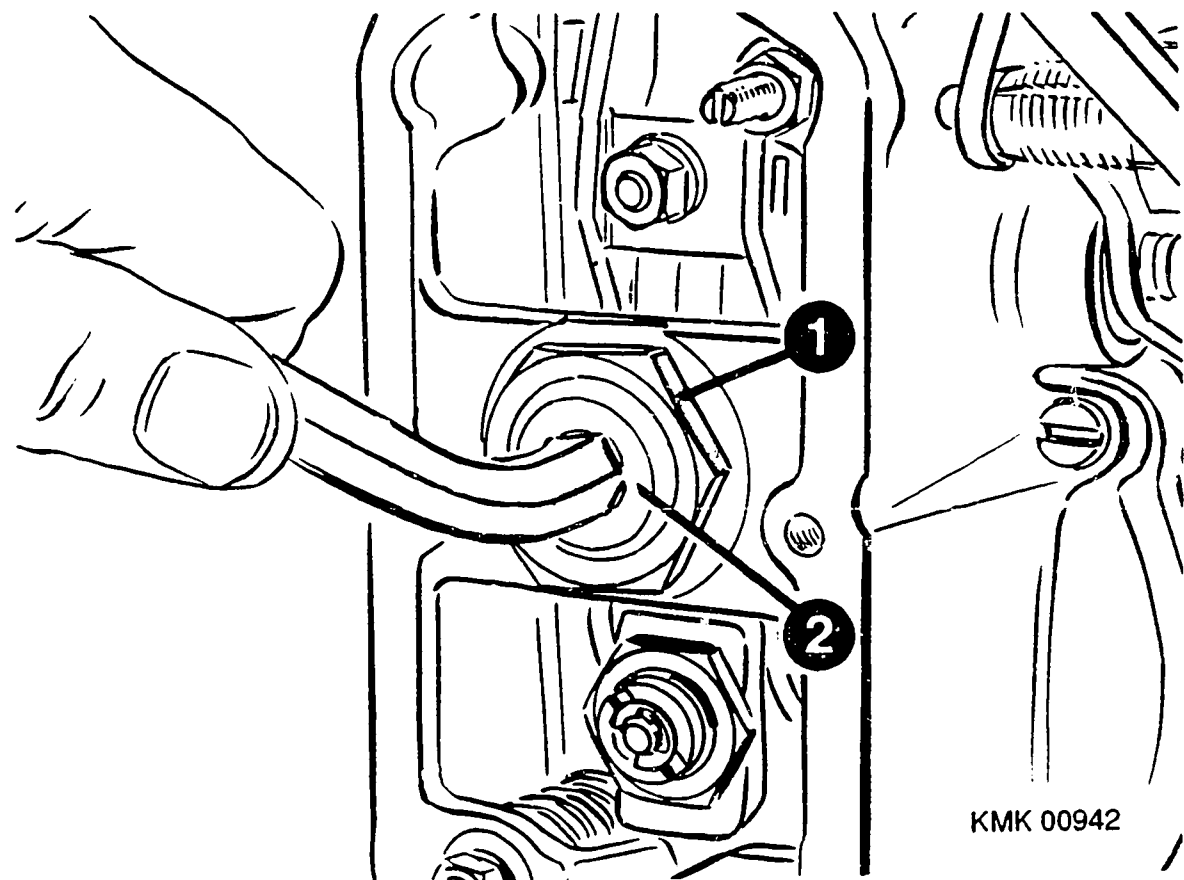

- 1 = Hexagon nut
- 2 = Threaded sleeve

ADJUSTING FULL-LOAD SPEED REGULATION

Section B, Item 8

Operate fuel-injection pump at indicated speed.
Loosen hexagon nut.
Screw out threaded sleeve until stated control-rod travel is attained.

Tighten hexagon nut to 25...45 Nm.

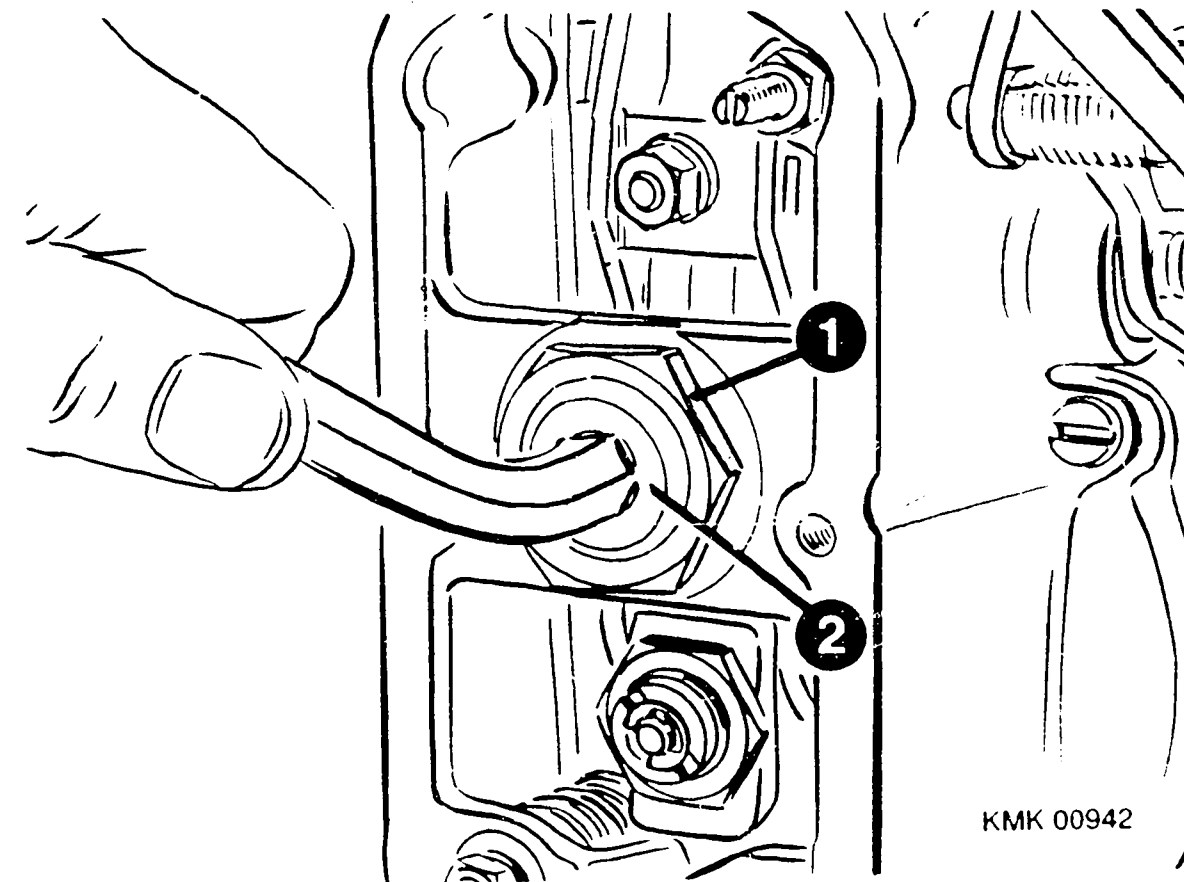

- 1 = Hexagon nut
- 2 = Threaded sleeve

CHECKING HIGH IDLE

Section C, Item 16

Operate fuel-injection pump at stated speed and measure delivery.

The measured delivery must be attained.
If necessary, effect correction at threaded sleeve.
Loosen hexagon nut.
Always comply with control-rod-travel tolerance in line with Section B, Item 8.
After effecting correction, tighten hexagon nut to 25...45 Nm.

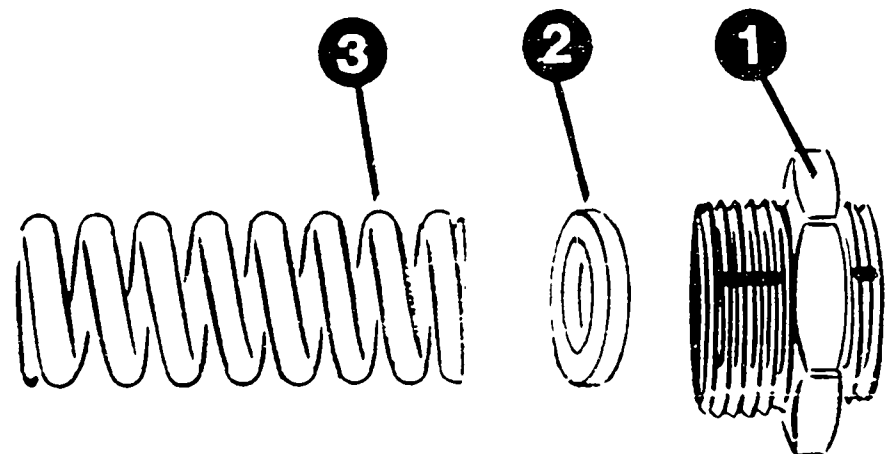

KMK 00943

- 1 = Threaded sleeve with hexagon nut
- 2 = Plain washer
- 3 = Governor spring

If the required delivery is not obtained without exceeding the control-rod-travel tolerance, check freedom of movement of governor linkage; replace governor spring.

Note:

Install teflon-coated side of plain washer facing retainer.

After replacing governor spring, repeat governor adjustment as of Coordinate B17.

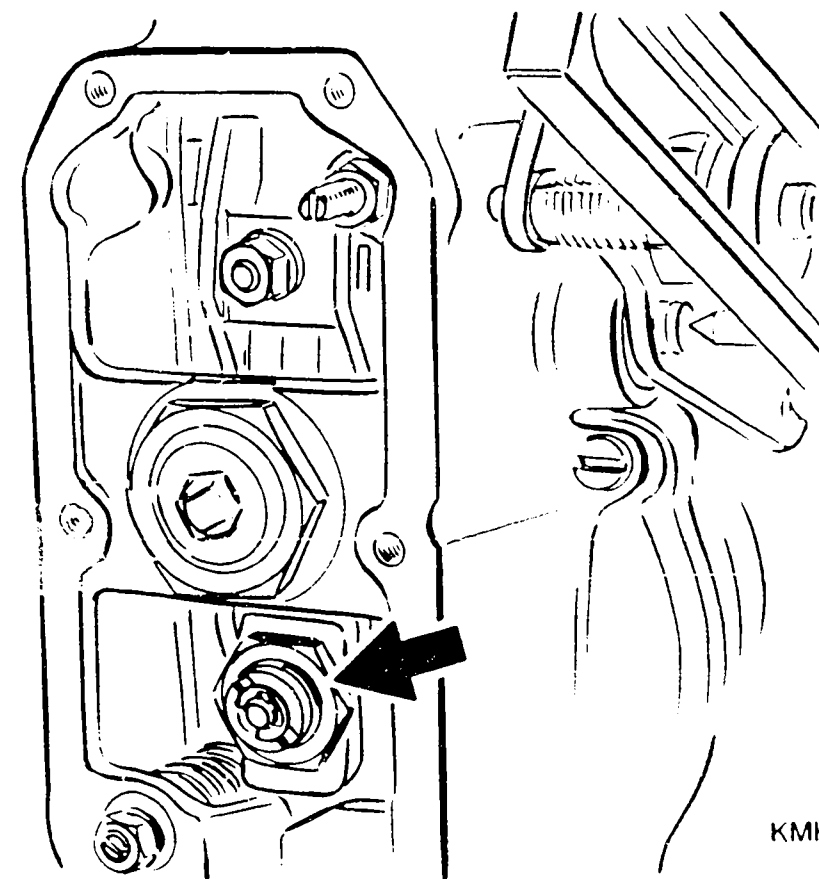

KMK 00940

Arrow = Spring retainer (torque-control retainer)

CHECKING POSITION OF SLIDING SLEEVE

Section B, Item 10

Operate fuel-injection pump at appropriate speed. Control-rod travel as per test-specification sheet must be attained. Correct slight deviations (± 0.3 mm) by adjusting torque-control retainer.

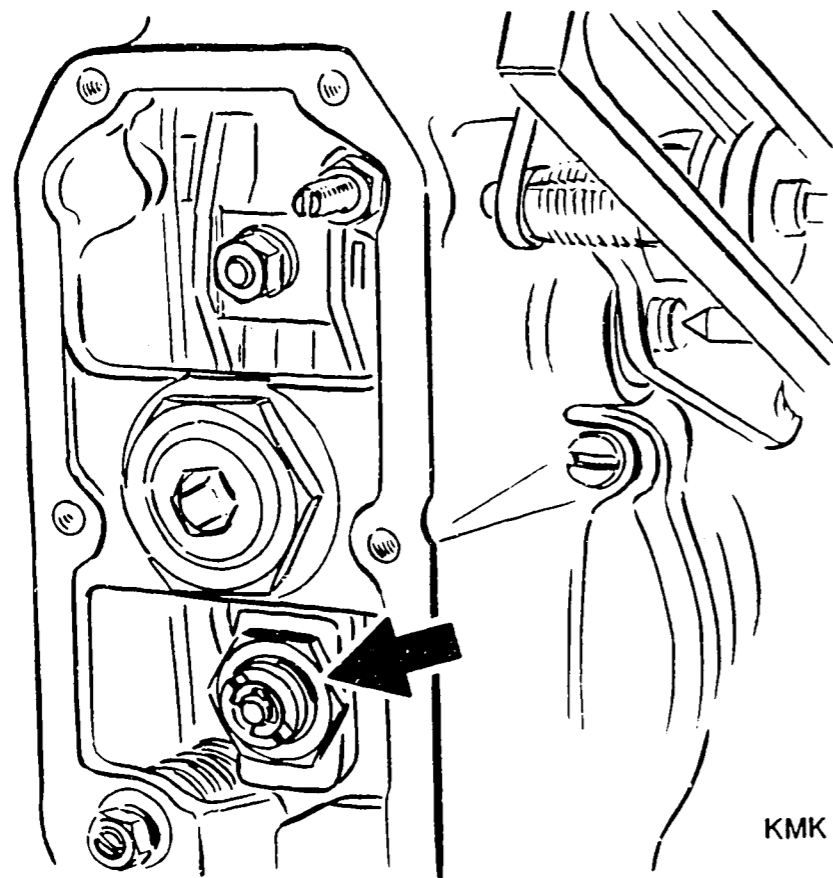

KMK 00940

Arrow = Spring retainer (torque-control retainer)

CHECKING TORQUE-CONTROL PROFILE

Section B, Items 13 and 7
Section C, Items 17 and 19

Operate fuel-injection pump at speed as per Section B, Item 13 and check control-rod travel on dial indicator. Check delivery as per Section C, Item 17 at same speed.

Operate fuel-injection pump at speed as per Section B, Item 7 and check control-rod travel. Check delivery in accordance with Section C, Item 19. In the event of deviations, renew spring retainer (torque-control retainer).

After replacing spring retainer, repeat governor adjustment as of Coordinate B17.

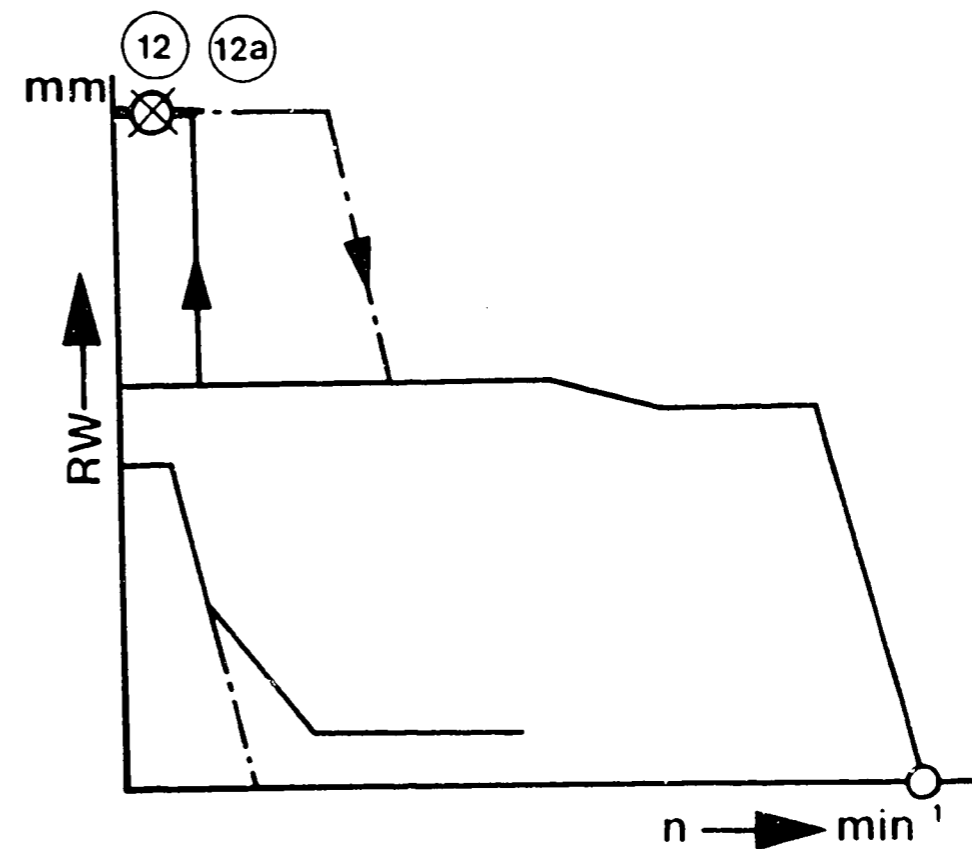

KMK 00944

RW = Control-rod travel
n = Fuel-injection-pump speed

CHECKING STARTING CONTROL-ROD TRAVEL AND MEASURING DELIVERY

Section B, Item 12
Section C, Item 12a

Position control lever of governor against full-load stop (head of hexagon-socket-head cap screw on governor-control-lever side) and fix.

Operate fuel-injection pump at speed as per Section B, Item 12 and check control-rod travel on dial indicator. If control-rod travel is not obtained, check freedom of movement of control rod (e.g. control rod catching).

Check delivery as per Section C, Item 12a at same speed.

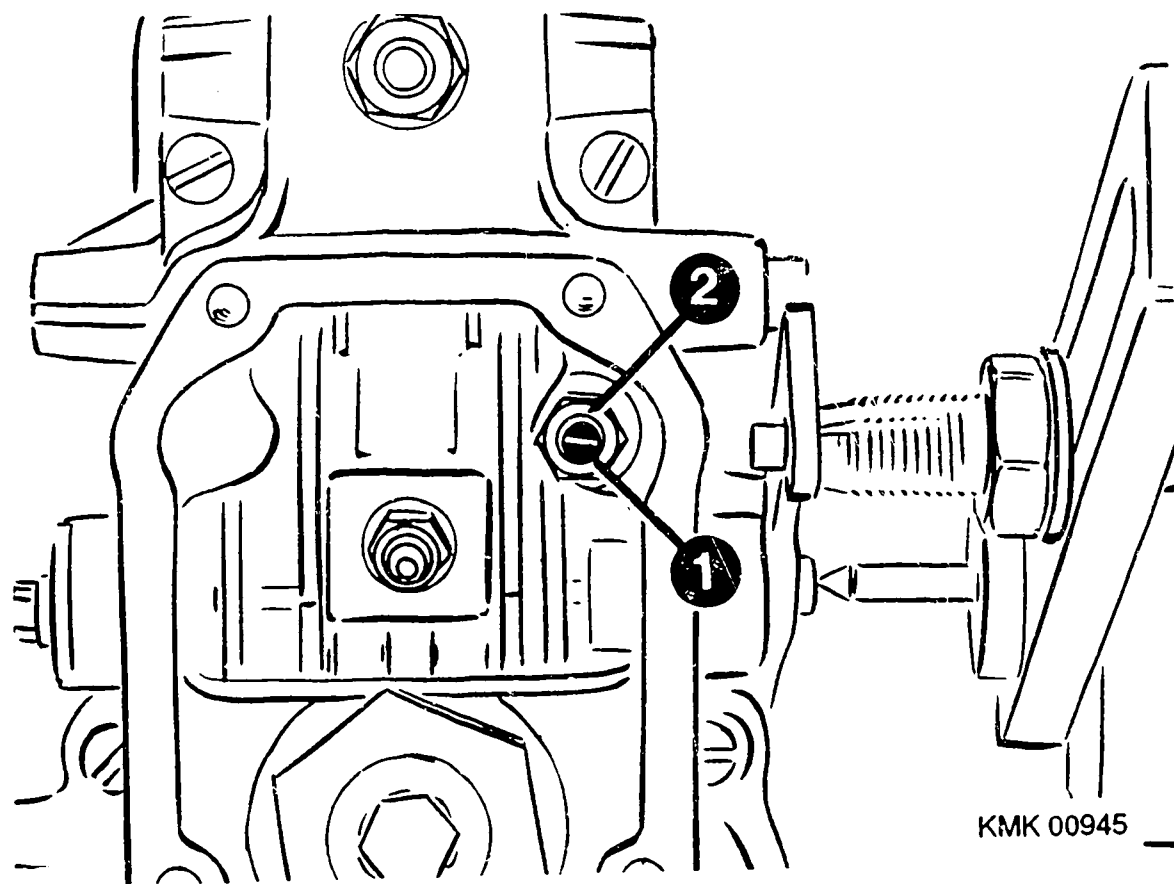

1 = Adjusting screw, idle control lever
 2 = Hexagon nut

ADJUSTING POSITION OF IDLE CONTROL LEVER

(2nd page of test-specification sheet)

Operate fuel-injection pump at speed as per test-specification sheet.
 Release control lever from fixture.
 After loosening hexagon nut, screw in adjusting screw until control-rod travel is obtained.

The resultant control-lever deflection must be within the prescribed tolerance as per Section B, Item 1.

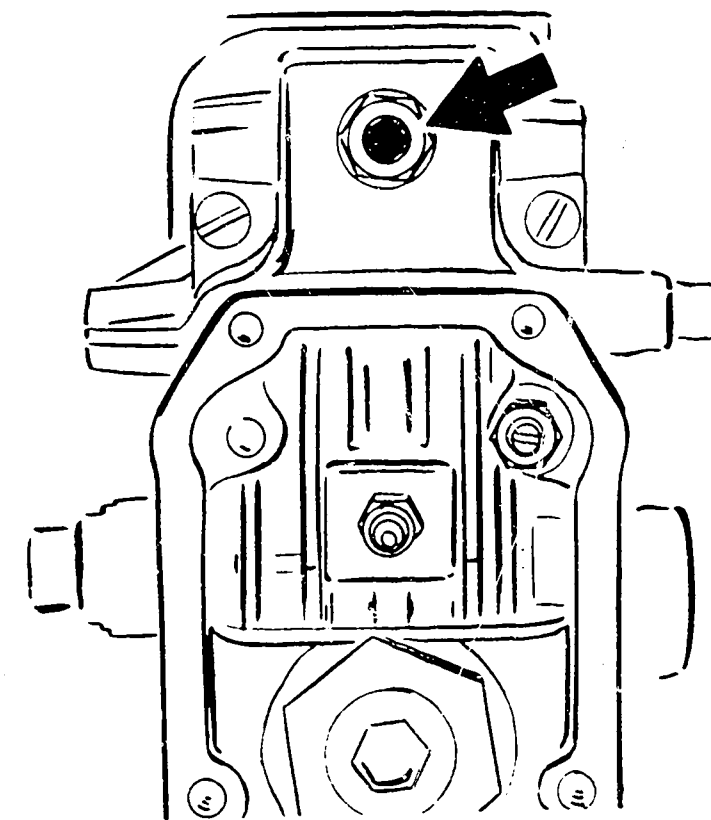

Arrow = Idle adjusting screw

ADJUSTING IDLE CONTROL-ROD TRAVEL AND MEASURING DELIVERY

Section B, Item 2
 Section C, Item 15

Operate fuel-injection pump at speed as per Section B, Item 2.
 Position control lever against idle stop.
 Screw in idle adjusting screw until stated control-rod travel is obtained.

Release control lever from fixture and move it back and forth.
 Fix control lever in idle position.
 Set control-rod travel must be re-attained.
 In the event of deviations, repeat adjustment.
 Measure delivery as per Section C, Item 15.
 If delivery is not attained, correct control-rod travel within tolerance.

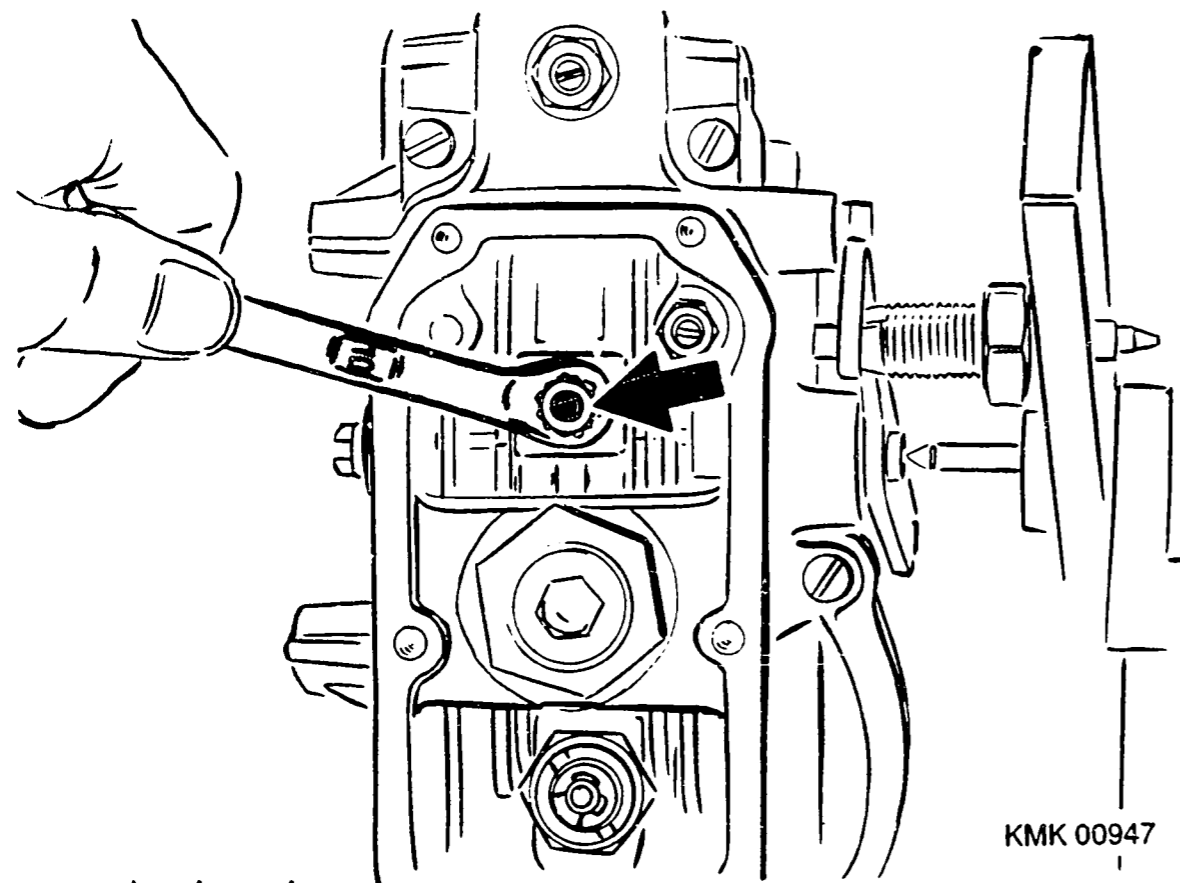

Arrow = Lock nut

ADJUSTING IDLE AUXILIARY SPRING (POPPET)

Section B, Item 3

Operate fuel-injection pump at speed as per Section B, Item 3.

Control lever is in contact with idle stop. Screw lock nut in direction of governor linkage until resultant control-rod travel is exceeded by amount indicated in test-specification sheet (back of sheet); idle control-rod travel increases by this amount.

Loosen control lever whilst retaining set speed and move it back and forth once.

Fix control lever again in idle position. Set control-rod travel must be attained.

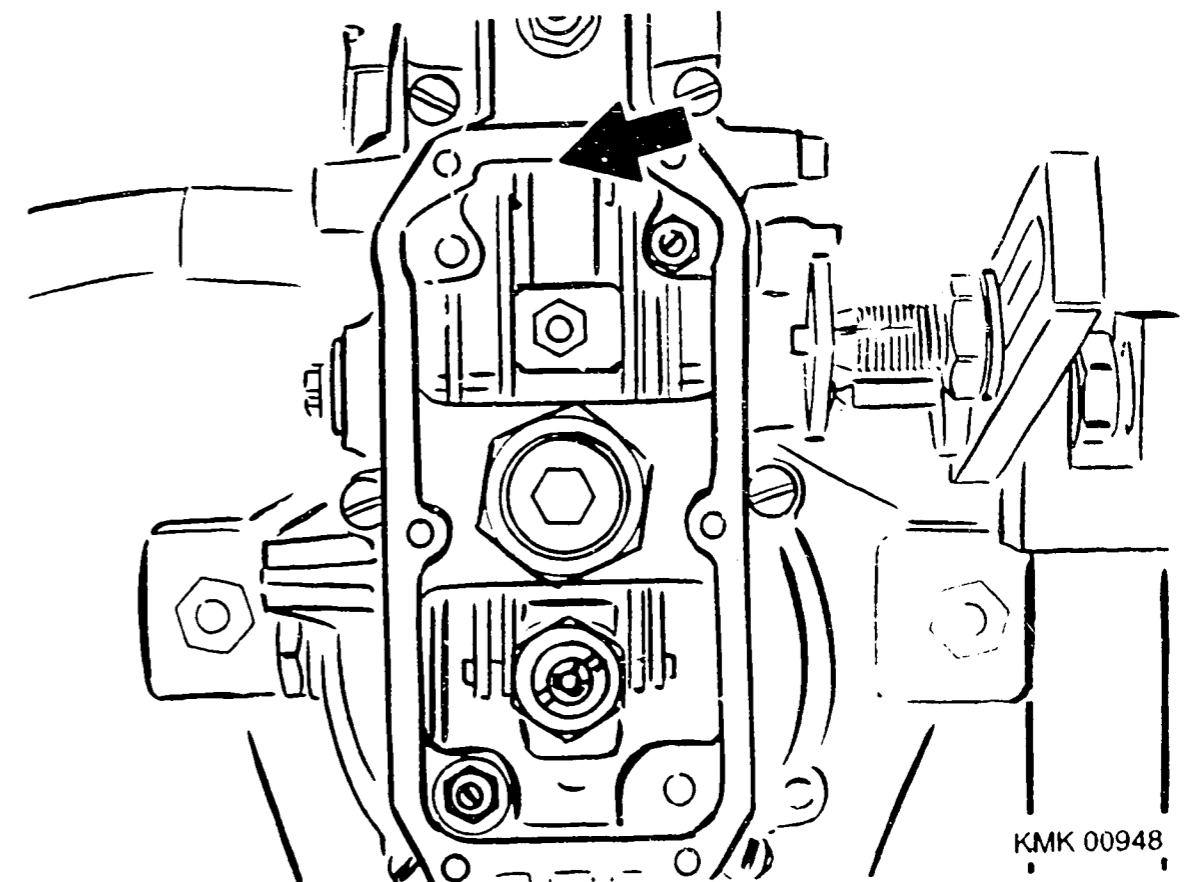

Arrow = Leaf spring

CHECKING LOAD TAKE-UP

Section B, Item 1

Operate fuel-injection pump in accordance with Section B, Item 1.

Check control-rod travel on dial indicator.

In the event of deviations from set value, check governor linkage for freedom of movement.

If necessary, renew leaf spring.

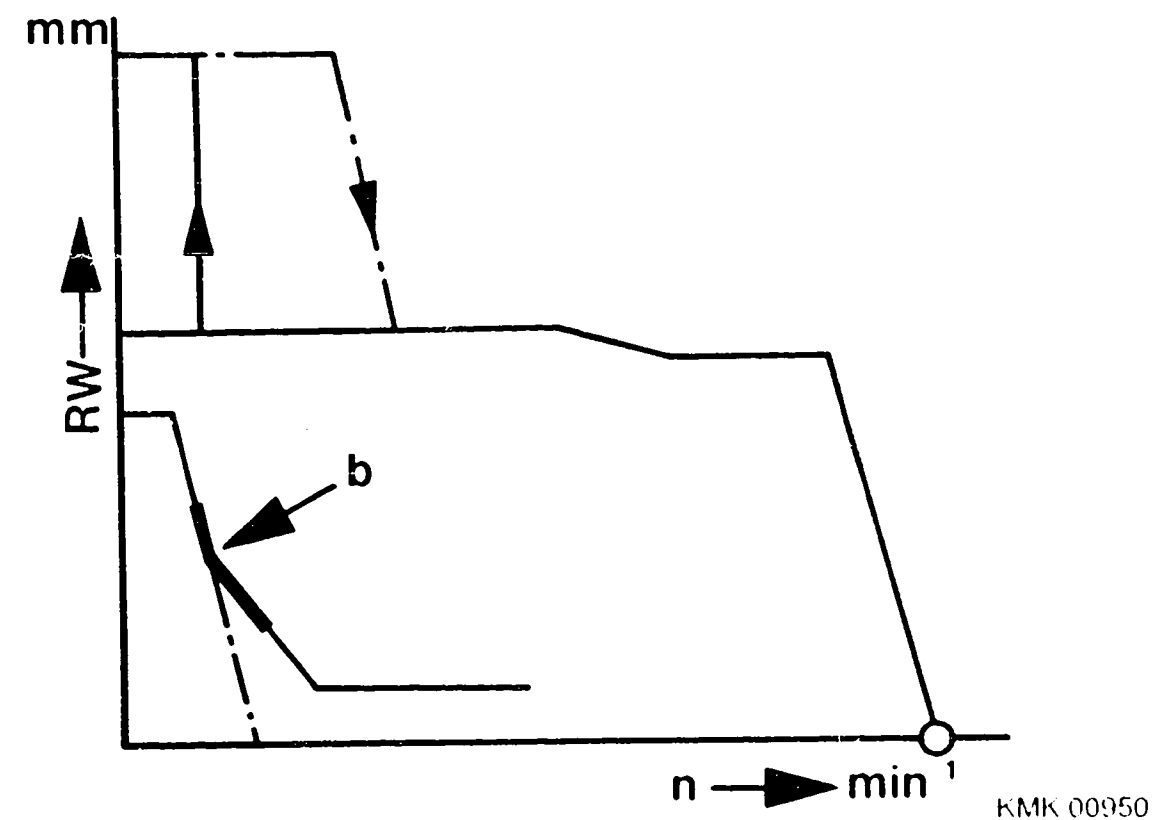
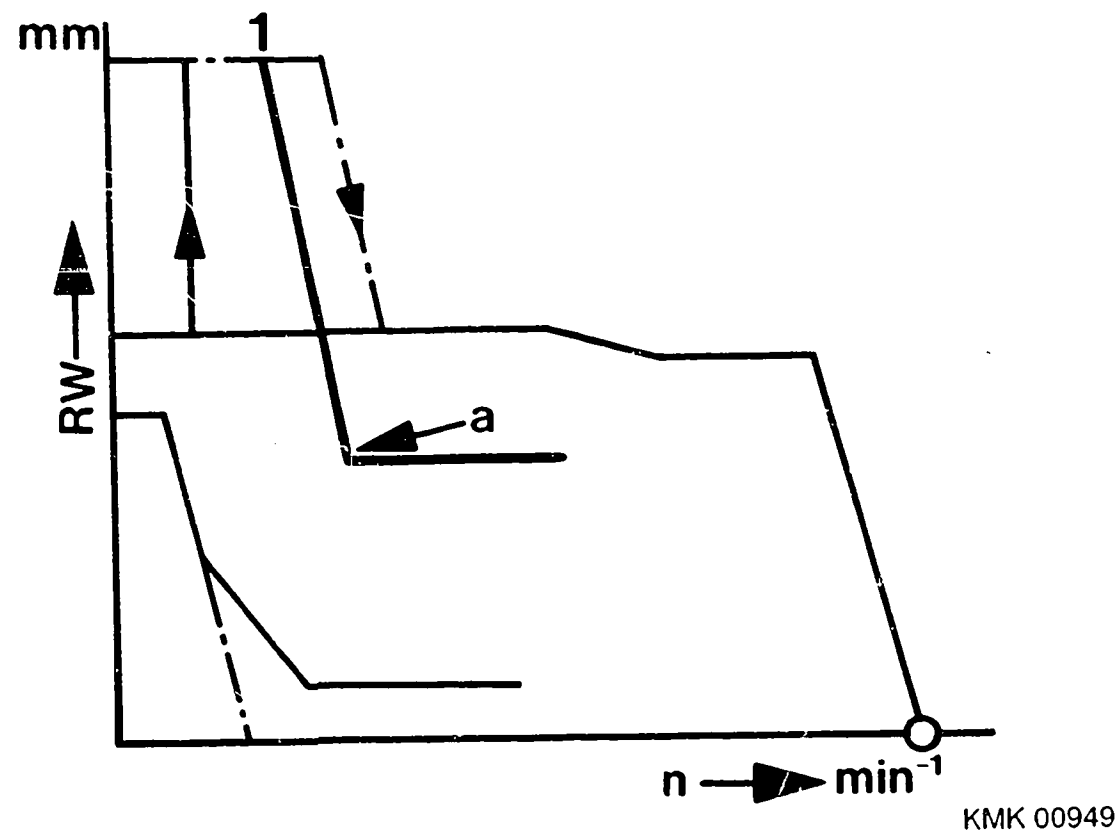

RW = Control-rod travel
 n = Fuel-injection-pump speed

RW = Control-rod travel
 n = Fuel-injection-pump speed

**IDLE AUXILIARY SPRING SHUTOFF
 (CHECKING POPPET SHUTOFF)**

Correct deviations at adjusting screw for poppet shutoff.

2nd page of test-specification sheet

Before effecting correction, check idle auxiliary spring shutoff with smaller angle (2nd control-lever indication on test-specification sheet).
 Fix control lever in accordance with indication given on test-specification sheet (back of sheet).

Fix governor control lever in accordance with indication given in test-specification sheet.
 Uniformly increase drive speed of fuel-injection pump from "0" to speed given in test-specification sheet.

An unregulated stage is not permitted within the stated speed, i.e. the control-rod travel must change continuously with increasing speed (point b).

No change in control-rod travel is permitted up to speed indicated on test-specification sheet following switching point to part-load control-rod travel (point "a" on upper governor curve).

Correct deviations at adjusting screw of poppet shutoff. To do so, remove governor cover.

If there is no deviation, continue as of Coordinate C10

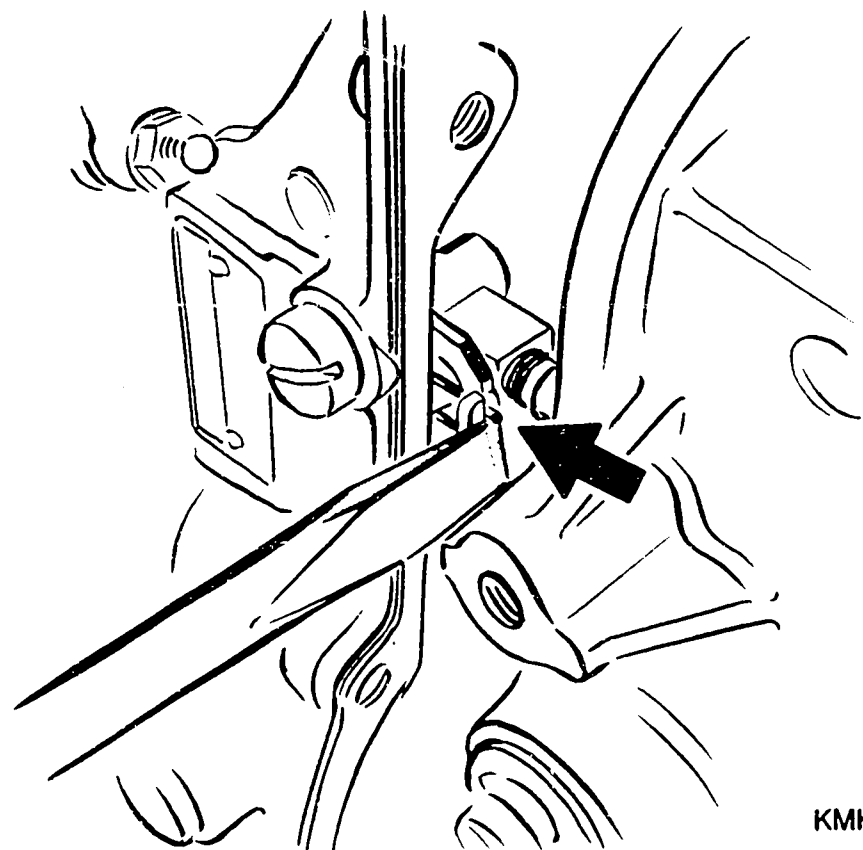

KMK 00951

CHECKING SETTING OF IDLE AUXILIARY SPRING SHUTOFF

Remove timing-advance device.

Remove fastening screws from governor housing.

Pull back governor housing.

Disengage clamping spring from connecting pin of fulcrum lever (arrow).

Detach governor housing from pump housing and clamp in position in vice (make use of protective jaws.)

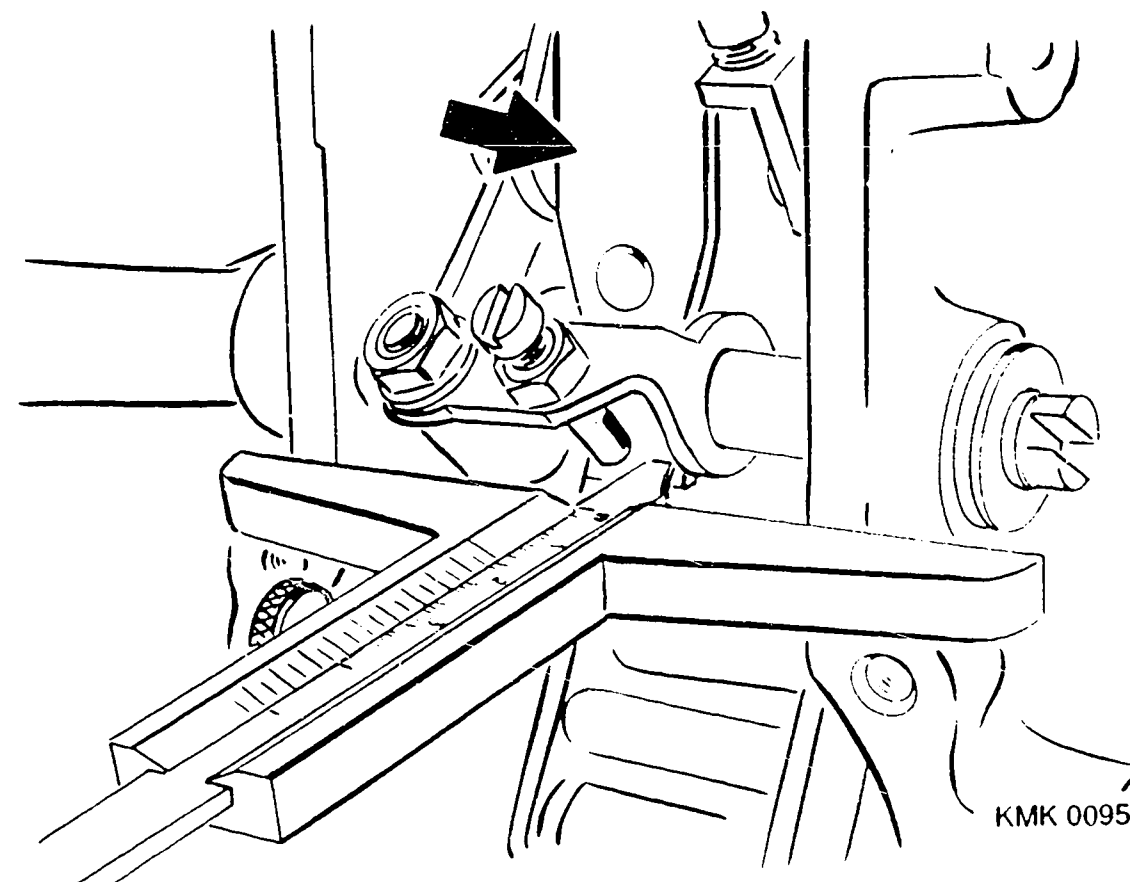

KMK 00952

Move control lever of governor to idle position and hold.

Use depth gauge to determine distance between governor cover and idle auxiliary spring (arrow) at end of spring.

Note down distance "1".

Position control lever against full-load stop and hold.

Measure distance between governor cover and over-compressed idle auxiliary spring.

Note down distance "2".

Subtract dimension 1 from dimension 2.

The difference between the two dimensions must correspond to the set value.

Set value:

up to FD 044 = 2.8...3.2 mm

as of FD 045 = 2.6...2.7 mm

Correct dimensions if necessary.

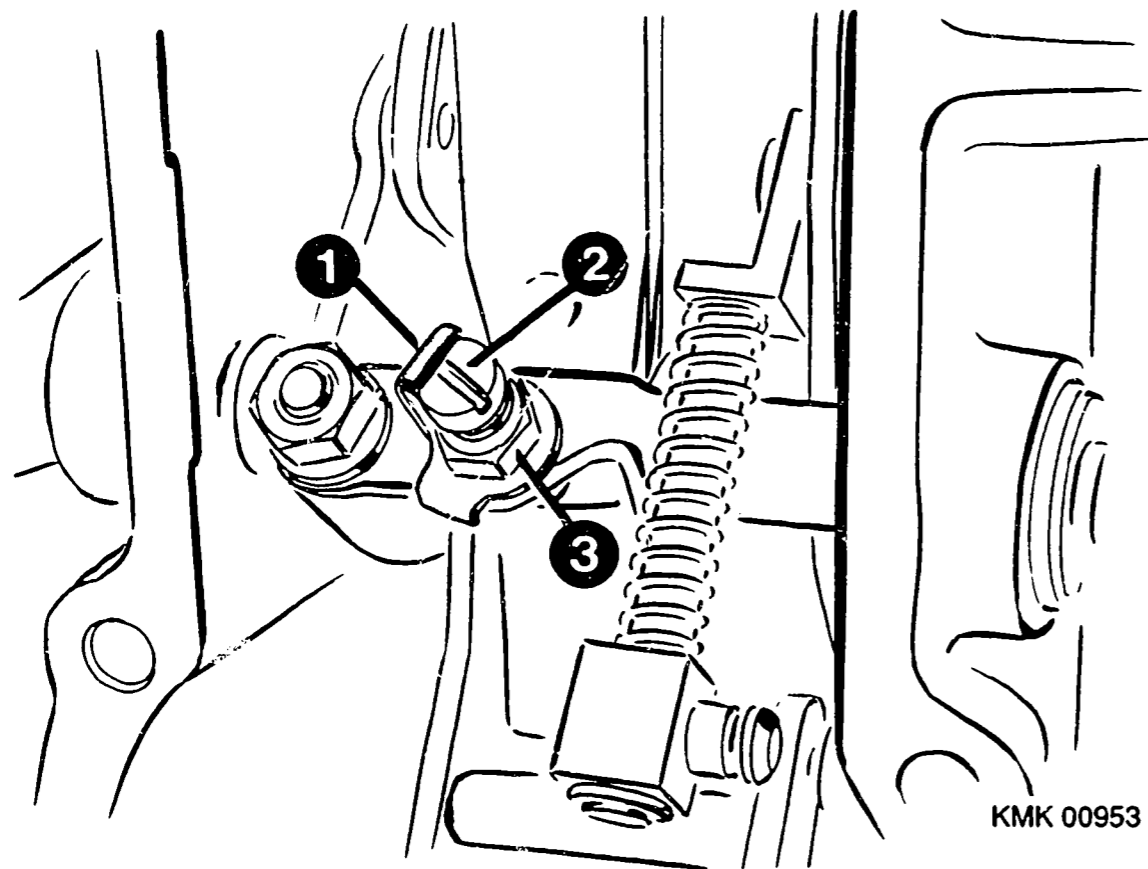

KMK 00953

- 1 = Tab washer
- 2 = Adjusting screw
- 3 = Hexagon nut

CORRECTING IDLE AUXILIARY SPRING SHUTOFF

Bend open tab washer if fitted. Loosen hexagon nut. Screw out adjusting screw and remove tab washer. Degrease adjusting screw and hexagon nut and coat thread with Loctite 601 (green). Fit adjusting screw with hexagon nut.

Move control lever of governor to idle position and hold.

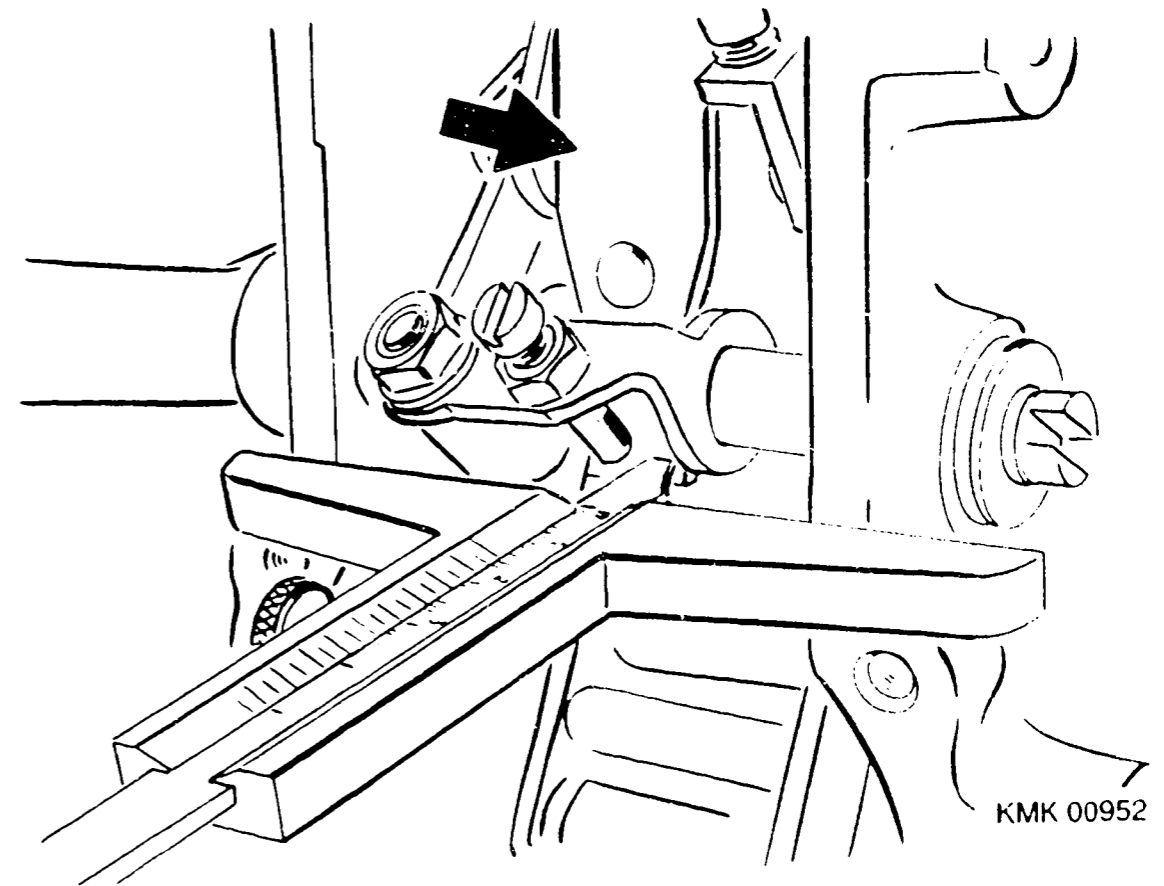

KMK 00952

Arrow = Idle auxiliary spring

Use depth gauge to measure distance between governor cover and idle auxiliary spring. Measurement point at end of spring. Note down dimension "1".

Position control lever of governor against full-load stop and hold.

Measure distance between governor cover and over-compressed idle auxiliary spring. Note down dimension "2".

Turn adjusting screw until difference between dimensions 1 and 2 corresponds to set value.

Set value:
 up to FD 044 = 2.8...3.2 mm
 as of FD 045 = 2.6...2.7 mm

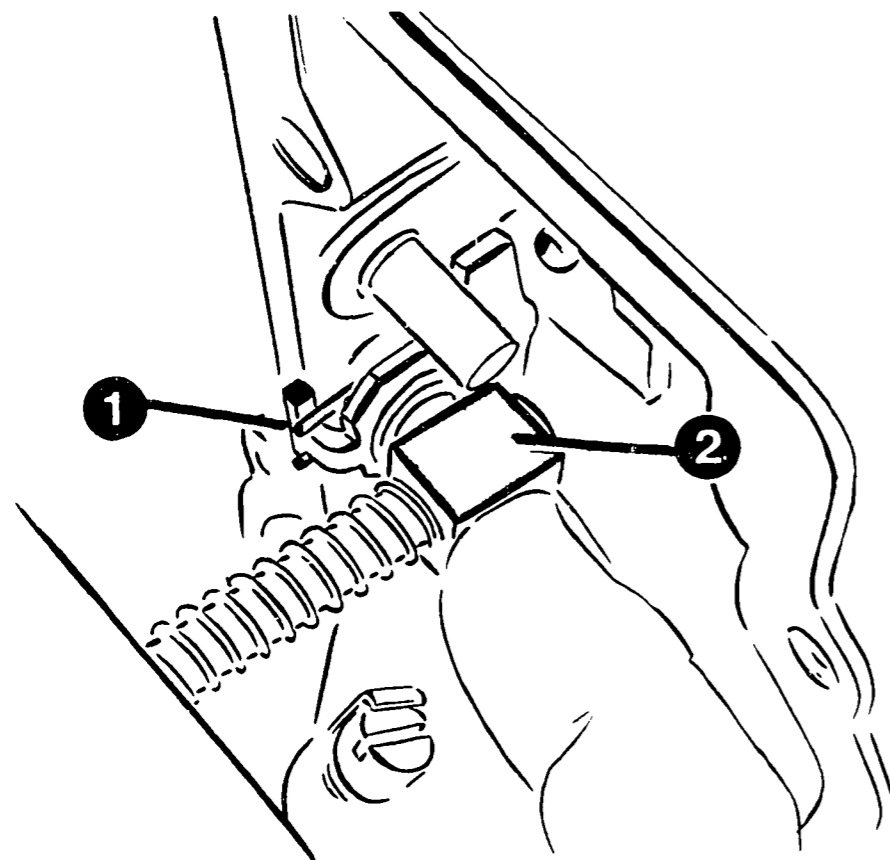

KMK 00954

- 1 = Clamping spring
- 2 = Fulcrum lever

INSTALLING GOVERNOR COVER

Place new sealing plate on governor cover.
Engage clamping spring (1) in control rod.

Position governor cover against lower edge of pump housing.
Insert sliding sleeve into flyweight assembly.
Engage fulcrum lever (2) in control rod.
Fit governor and tighten fastening screws to 5...7 Nm.

Attach setting device and repeat governor adjustment as of Coordinate B17.

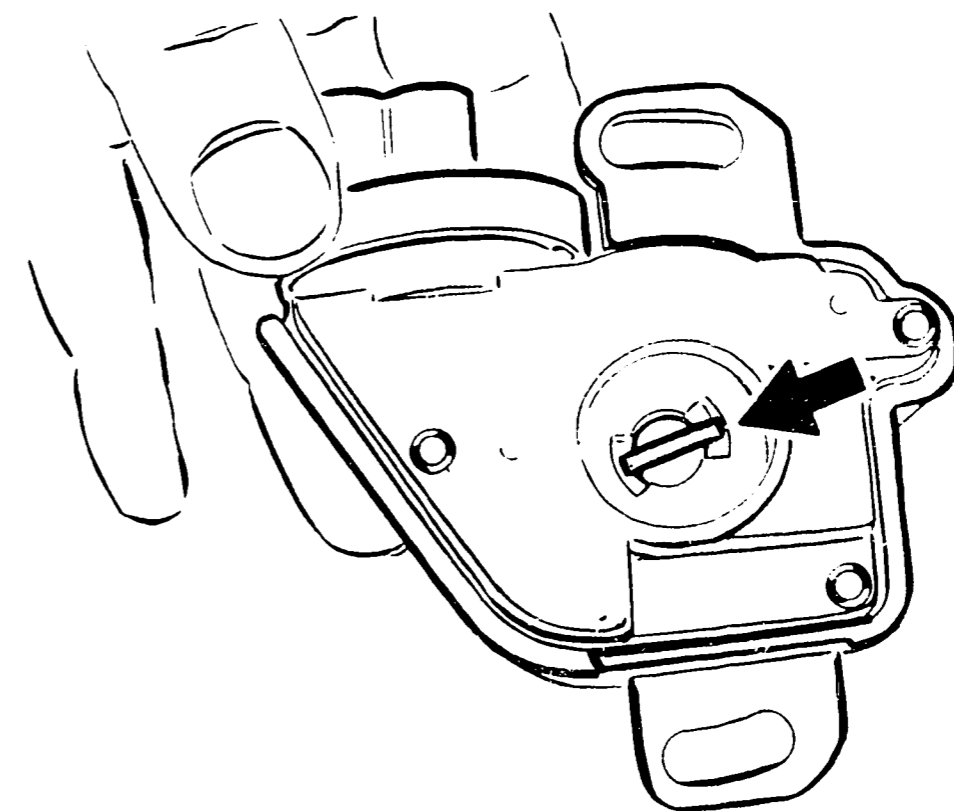

KMK 00955

FITTING VACUUM CONTROL VALVE

Move connecting piece (arrow) to center position.

If there is no vacuum control valve, continue as of Coordinate C12

CONCLUDING WORK

Check function of shutoff unit:

Given corresponding vacuum as per test-specification sheet, the pneumatic shutoff device must pull the control rod to control-rod travel "0".

Replace defective shutoff unit.

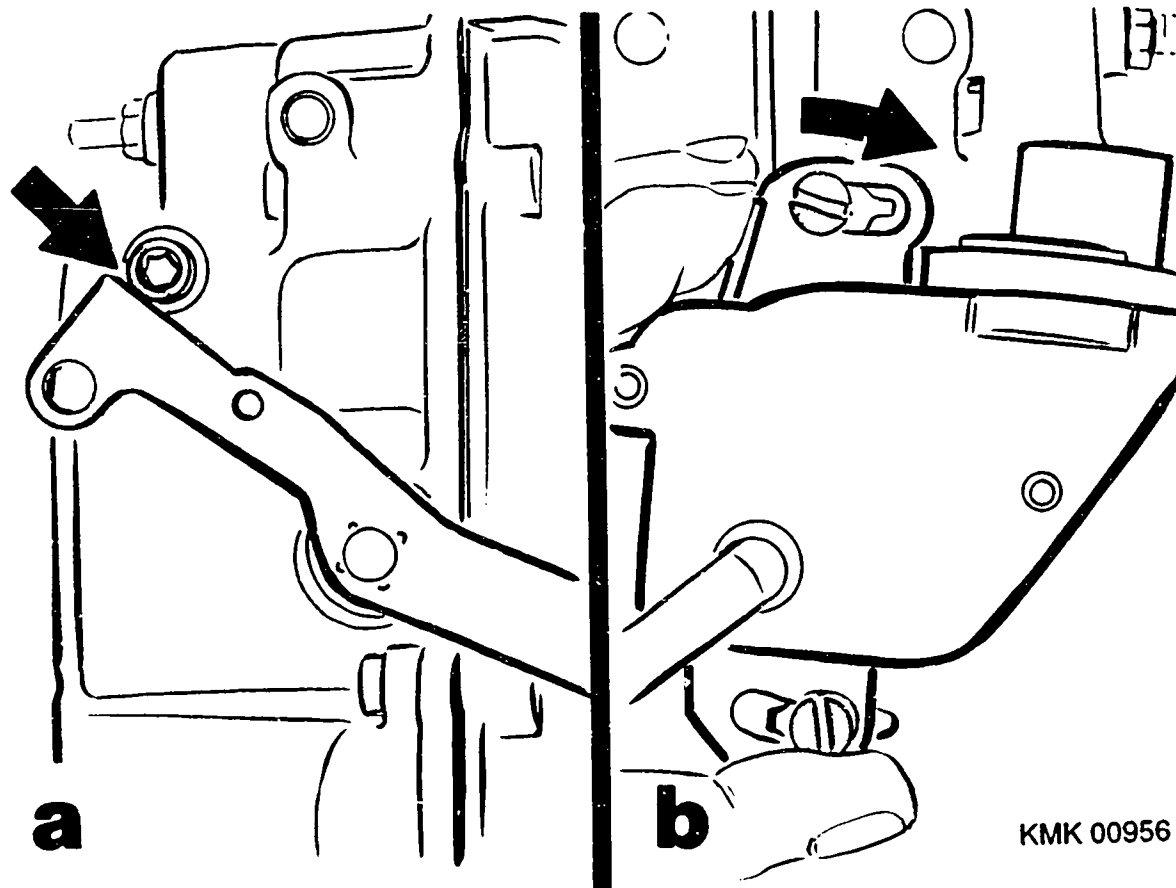

Position control lever of governor against full-load stop (picture a - arrow).

Attach vacuum control valve on opposite side of control lever.

Screw in fastening screws of vacuum control valve, but do not tighten them.

Swivel vacuum control valve in clockwise direction in full-load position of control valve until stop is felt (picture b - arrow).

Tighten fastening screws of vacuum control valve.

C11

C12

Fit closing cover with seal.

Remove control-rod-travel measuring device.
Detach control lever, setting device.

Completely assemble fuel-injection pump.
Remove fuel-injection pump with governor and
supply pump from test bench.

CHECKING FUEL-INJECTION PUMP FOR LEAKS

Seal all open tapped holes on governor and pump housing
with screw plugs.

Screw test cone KDEP 1045 onto end face of camshaft.

Connect compressed-air hose to test cone.
Test fuel-injection-pump assembly for leaks at 0.5 bar
gauge in oil bath.
Unscrew test cone.

Fit lead seal on fuel-injection pump and governor.

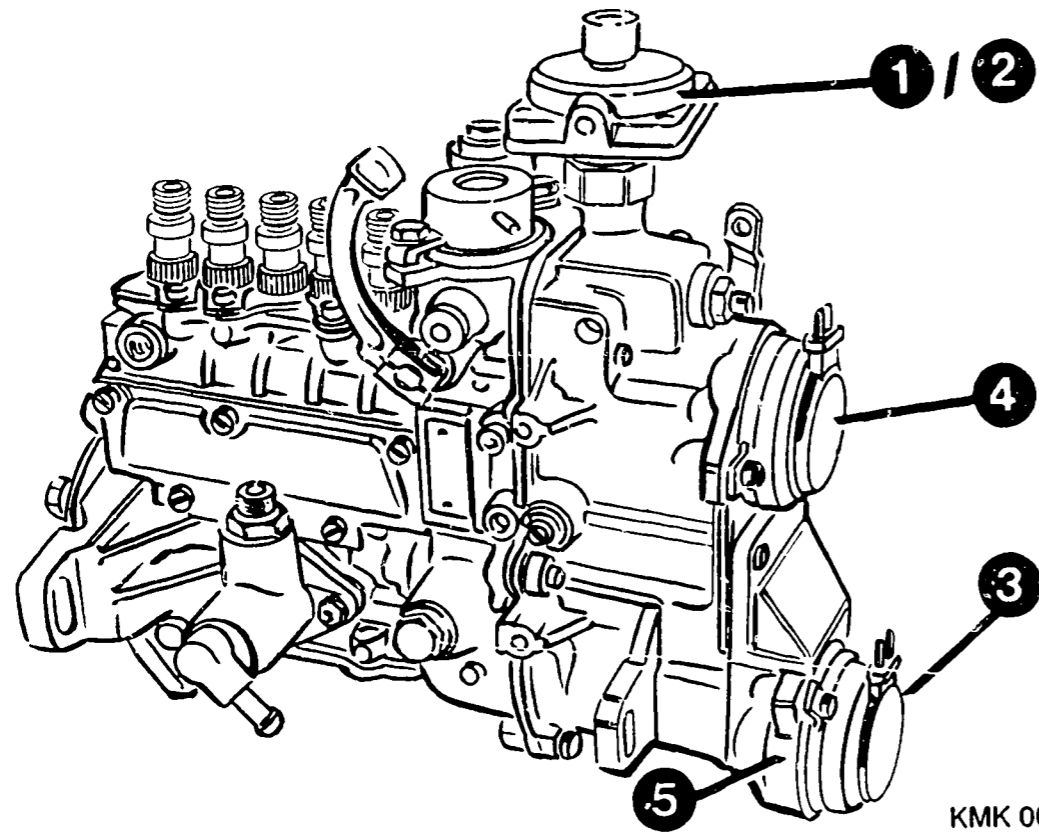

KMK 00957

ADJUSTING GOVERNOR RSF II (WITH START-OF-DELIVERY SENSOR SYSTEM)

* Preparation following pump repair

Insert seal between governor cover and pump.
 - Attach governor with built-in compound lever to fuel-injection pump.
 Do not fit closing cover of governor.

* If fitted:

- 1= Absolute boost pressure-dependent full-load stop (ALDA)
- 2= Ambient-pressure-dependent full-load stop (ADA)
- 3= Servo magnet, active surge damping (ARD)
- 4= Remove servo magnet, electronic idle-speed regulation (ELR).
- 5= Remove servo-magnet housing ARD.

Pay attention to shims when removing ADA/ALDA unit.

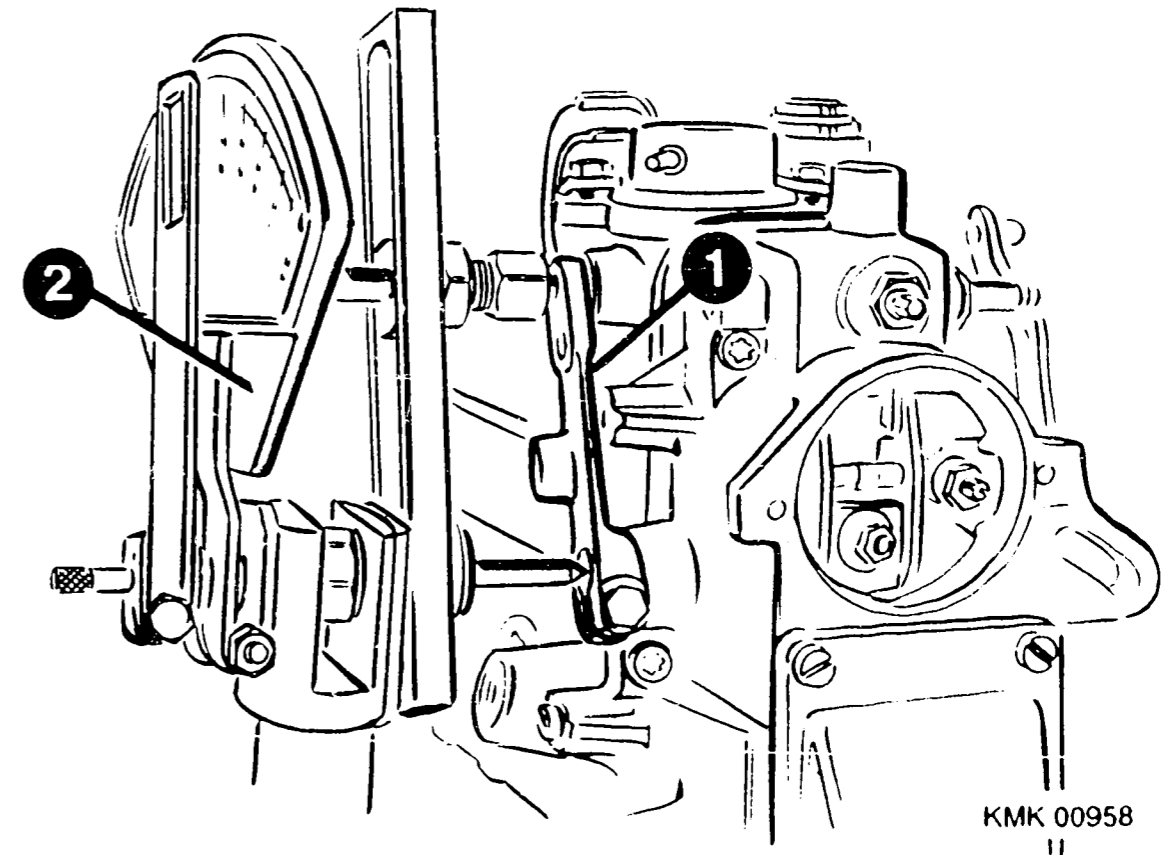

KMK 00958
 II

- 1 = Control lever
- 2 = Protractor

Attach protractor to control lever such that there is no stress.

Depending on type of test bench, attach auxiliary lever (control lever of RQV governor) if appropriate on opposite side of governor control lever.

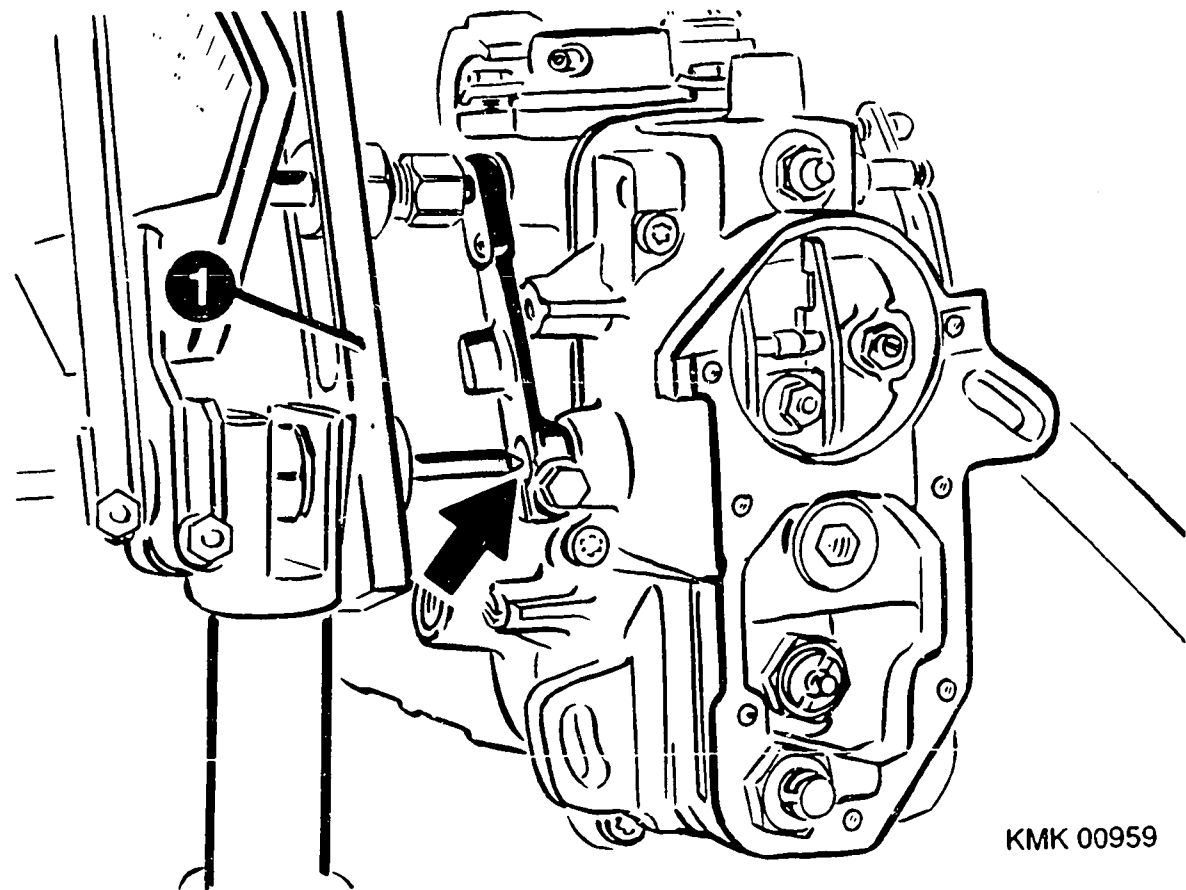

KMK 00959

1 = Swivelling lever

Attaching swivelling lever to control lever

Pointed pivot (arrow) of angle indicator must face center of control-lever shaft (arrow).
The swivelling arm of the setting device is attached to the control lever so as to be stress-free.

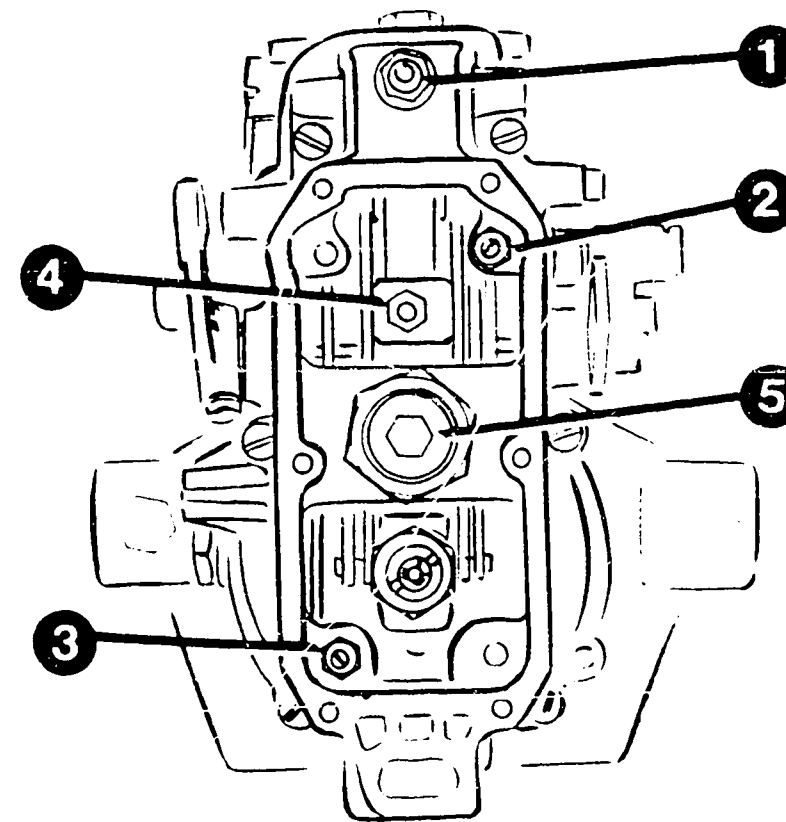

KMK 00937

- 1 = Idle adjusting screw *12.0 mm
- 2 = Idle stop screw * 7.0 mm
- 3 = Adjusting screw for full-load control-rod travel * 6.0 mm

GOVERNOR PRESETTINGS

* Measure distance between stud curvature and hexagon nut.

Note:

If there is no indication on the corresponding test-specification sheet of the static sliding-sleeve pre-travel, the above governor presettings are to be used.

If the sliding-sleeve pre-travel is indicated under "Remarks", all adjusting screws in the governor are to be moved back.

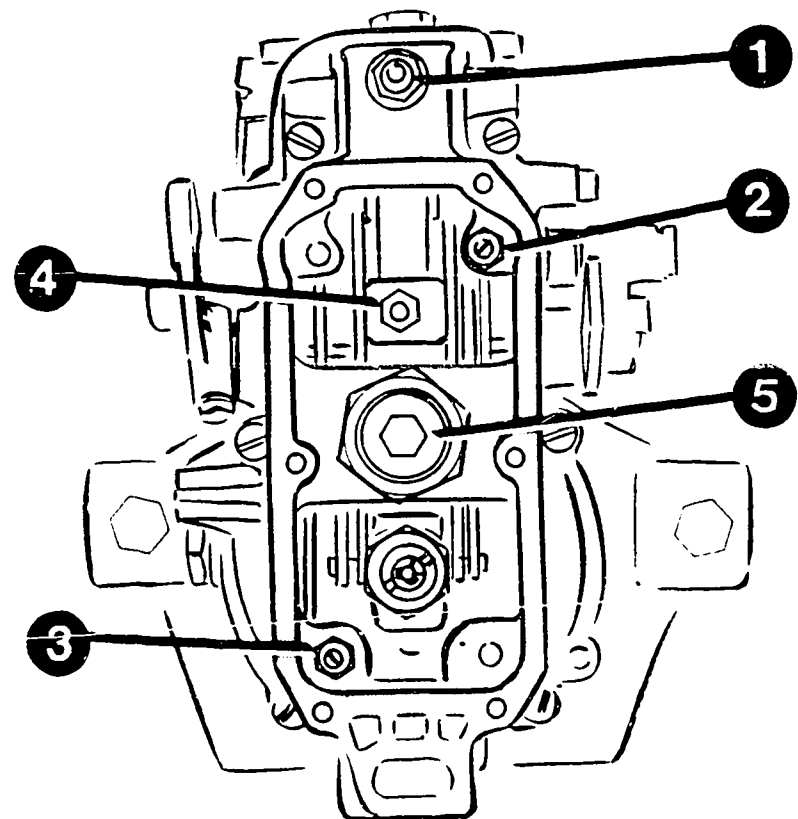

KMK 00937

4 = Poppet adjusting screw
5 = Adjusting screw, speed regulation

Screw out poppet adjusting nut as far as retainer (visible at start of thread).

Screw in threaded sleeve, full-load speed regulation until it is flush with hexagon nut.

Pour engine oil into governor and fuel-injection pump (200 cm³ in each case).
Set suction-chamber pressure on test bench to 1 bar.

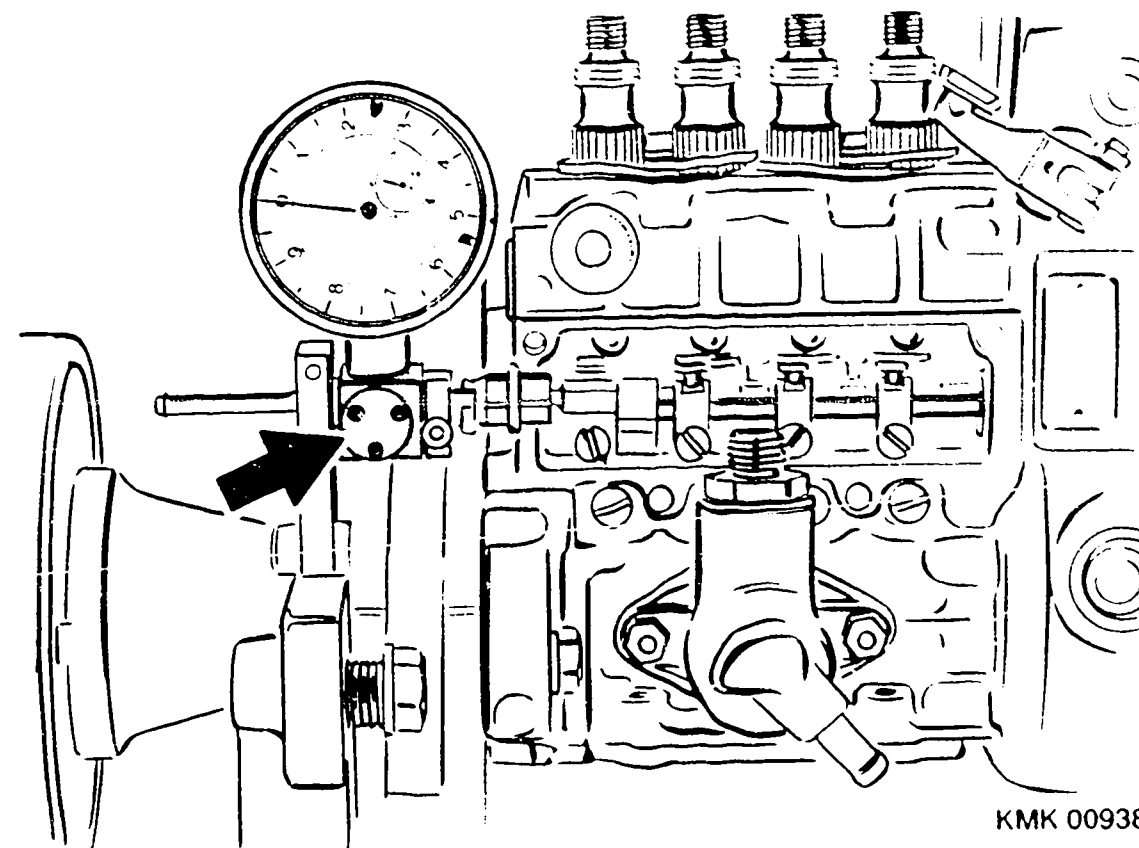

KMK 00938

Arrow = Control-rod-travel measuring device

ATTACHING AND ADJUSTING CONTROL-ROD-TRAVEL MEASURING DEVICE

Attach control-rod-travel measuring device 1 688 130 130 with accessories.
Set dial-indicator pointer in shutoff position of control rod to "0".

Move control rod from shutoff to full-load stop and check whether pointer of dial indicator reads "0" again in shutoff position.
Adjust dial-indicator pointer.

Position control lever against full-load stop.
Adjust setting device to 50° (refer to test-specification sheet).

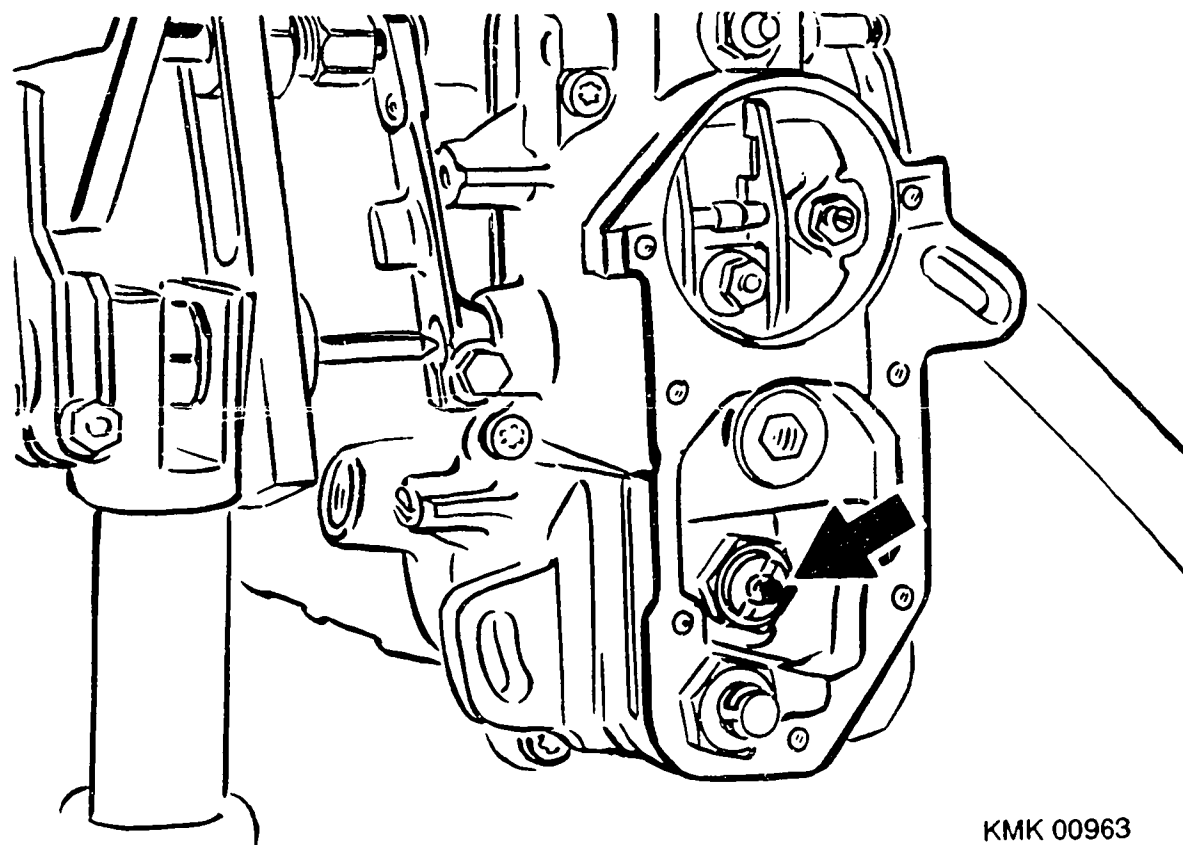

KMK 00963

Arrow = Spring retainer

STATIC IDLE-STAGE ADJUSTMENT

* Refer to back of test-specification sheet for sliding-sleeve pre-travel (mm)

If there is no indication of sliding-sleeve pre-travel, continue as of Coordinate C22

Set control lever to mid-position of idle control lever.

With speed "0", screw in spring retainer (torque-control retainer) with pin-type socket wrench KDEP 2968 until spring retainer makes contact with sliding sleeve. Do not over-compress spring retainer.

Then set sliding-sleeve pre-travel indicated on test-specification sheet by screwing out spring retainer. (1 turn = 1 mm).

Continue as of Coordinate C26

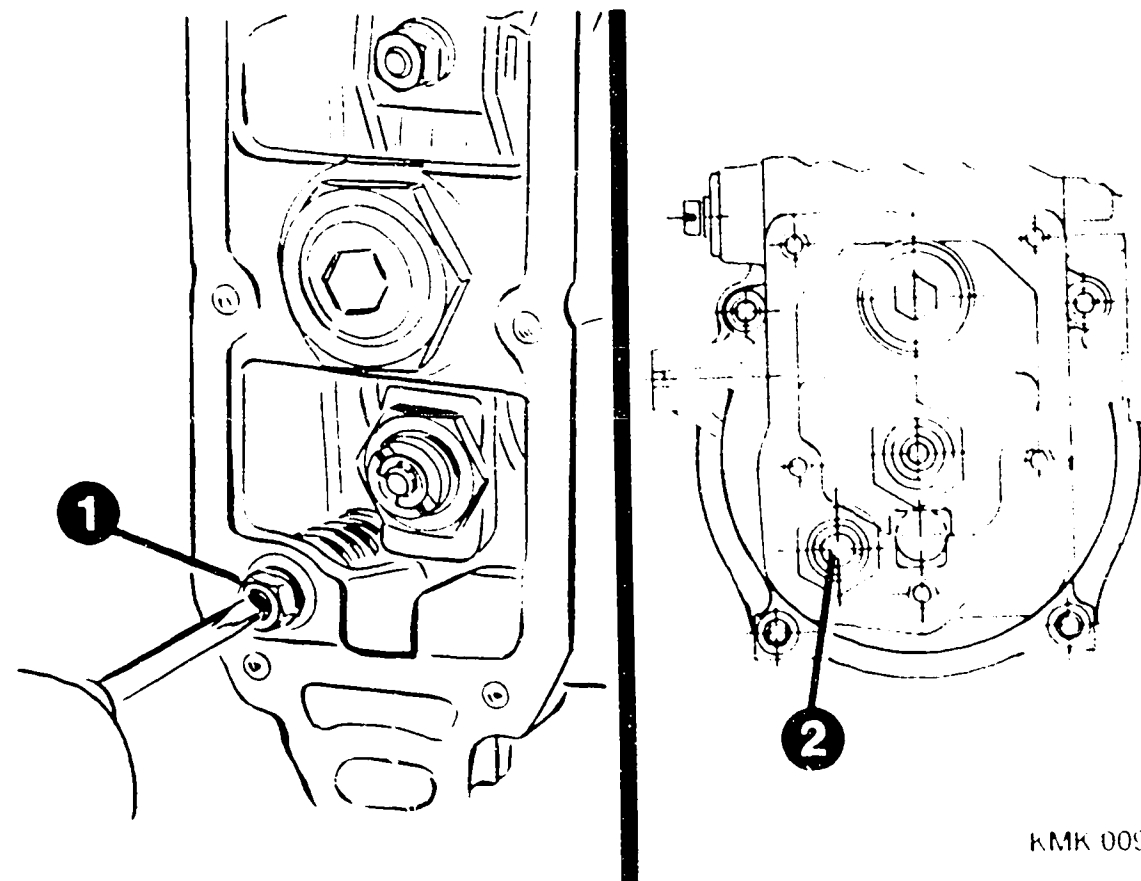

KMK 00983

- 1 = Adjusting screw for full-load control-rod travel
Pump with no active surge damping (ARD)
- 2 = Pump with (ARD)

DYNAMIC IDLE-STAGE ADJUSTMENT

* Adjustment applies to vehicle WITH NO two-mass flywheel; pay attention to note on test-specification sheet.

With two-mass flywheel as of Coordinate C24

Set full-load control-rod travel at speed "0" with control lever. If control-rod travel is not obtained, perform correction with adjusting screw for full-load control-rod travel. Fix control lever.

Operate fuel-injection pump at $n = 1000 \text{ min}^{-1}$. Loosen hexagon nut of spring retainer (torque-control retainer) with pin-type socket wrench KDEP 2968.

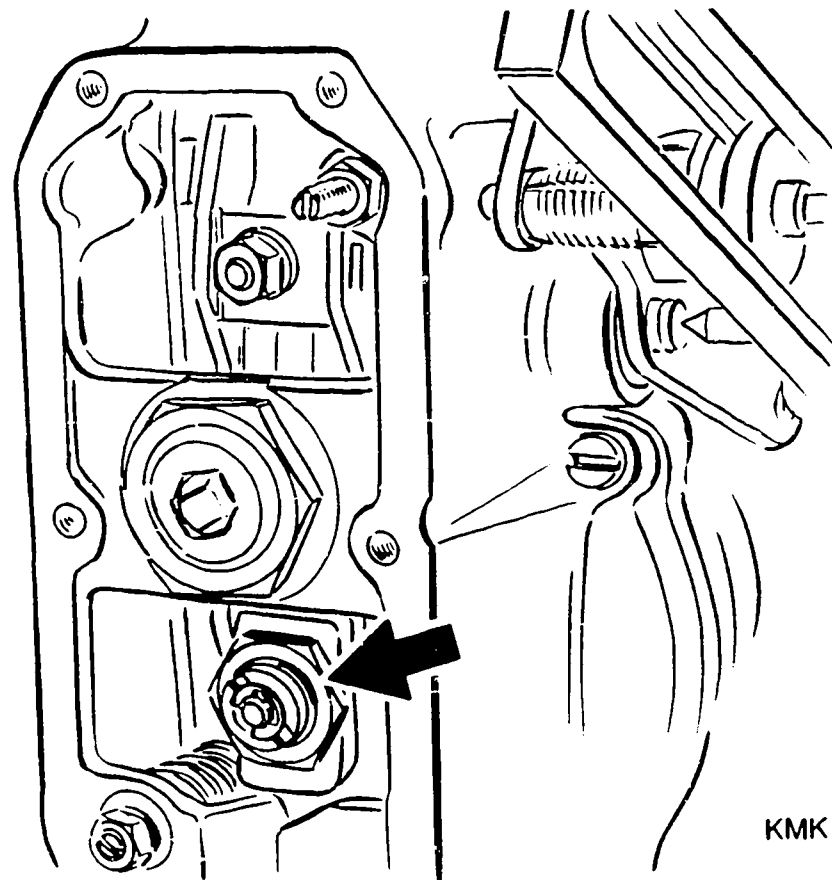

KMK 00940

Arrow = Spring retainer

Screw out spring retainer until control-rod travel is attained in line with test-specification sheet in Section "Adjusting position of idle control lever".
Tighten hexagon nut of spring retainer to 30...35 Nm.

Check control-rod travel again.

Continue as of Coordinate C26

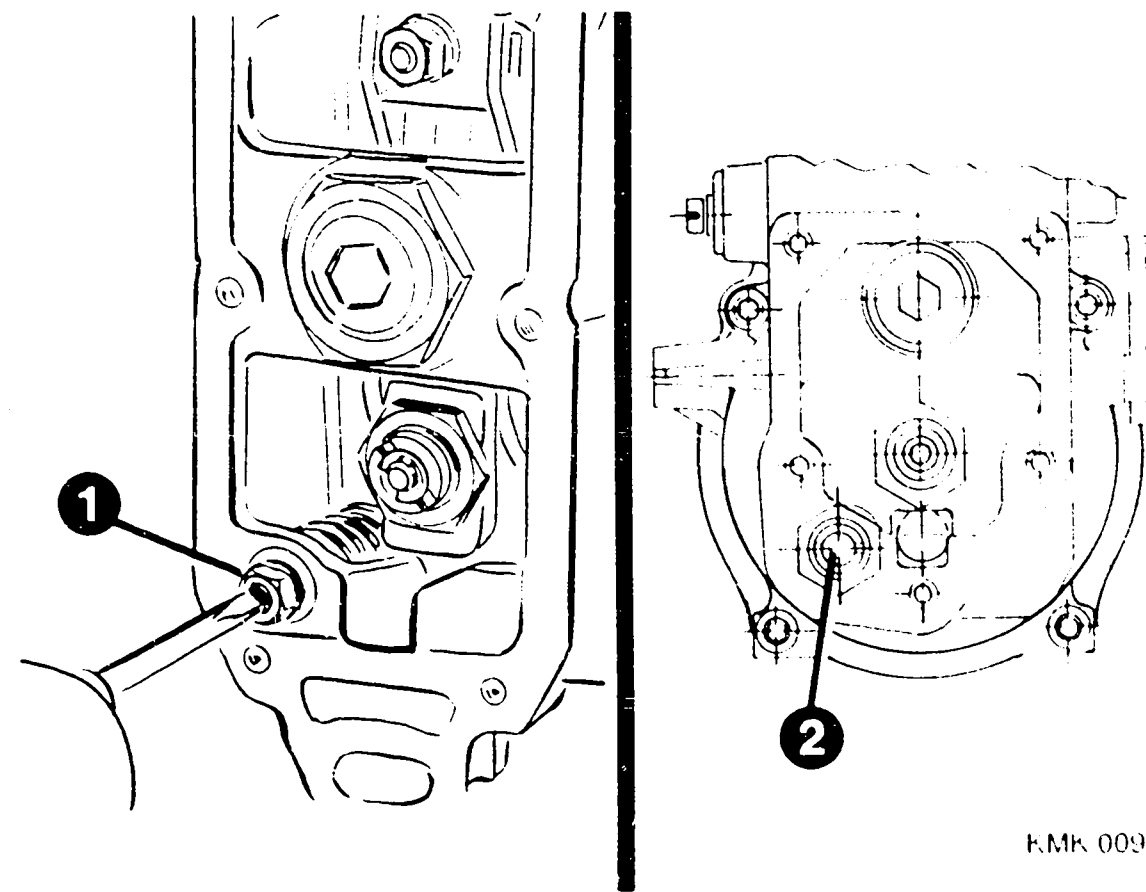

KMK 00983

- 1 = Adjusting screw for full-load control-rod travel
Pump with no active surge damping (ARD)
- 2 = Pump with ARD

DYNAMIC IDLE-STAGE ADJUSTMENT

Adjustment applies to vehicle with two-mass flywheel; pay attention to note on test-specification sheet

At speed "0", press against guide lever such that flyweights are in inner position. Maintain pressure and set 1st control-rod travel with control lever as per test-specification sheet in Section "TESTING LOWER RATED SPEED".

If control-rod travel is not attained, effect correction by means of adjusting screw for full-load control-rod travel.

Fix control lever.

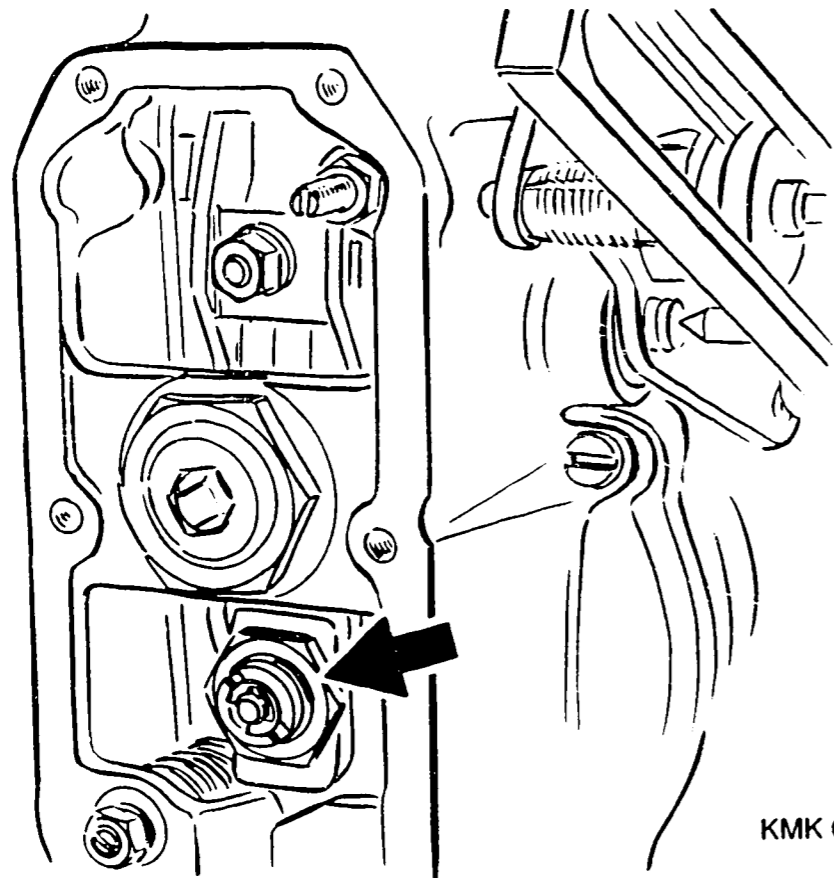

KMK 00940

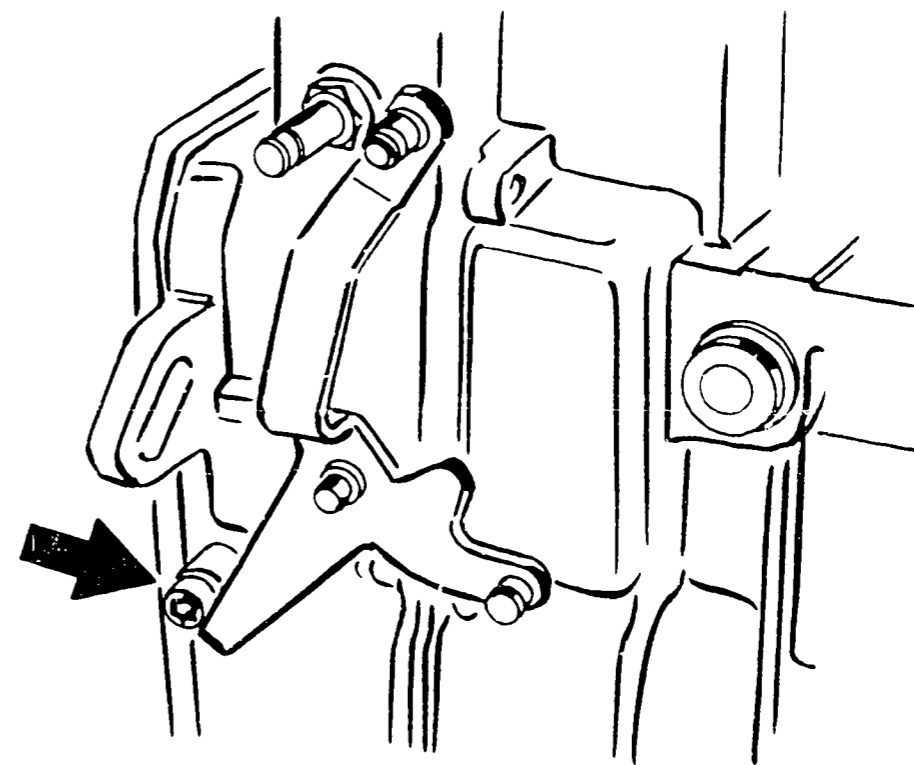

KMK 00965

Arrow = Spring retainer

Operate fuel-injection pump at $n = 1000 \text{ min}^{-1}$.

Loosen hexagon nut of spring retainer (torque-control retainer) with pin-type socket wrench KDEP 2968.

Screw out spring retainer until 4th control-rod travel as per test-specification sheet is obtained. Tighten hexagon nut of spring retainer to 30...35 Nm.

Start up fuel-injection pump with 1st speed indicated under "Testing" and check set control-rod travel. Effect correction by way of full-load adjusting screw.

Arrow = Full-load stop

ADJUSTING FULL-LOAD CONTROL-ROD TRAVEL AND MEASURING DELIVERY

* Section "full-load delivery at full-load stop and torque control, 1st speed indication"

Loosen control lever and position against full-load stop (head of hexagon-socket-head cap screw on governor-control-lever side)

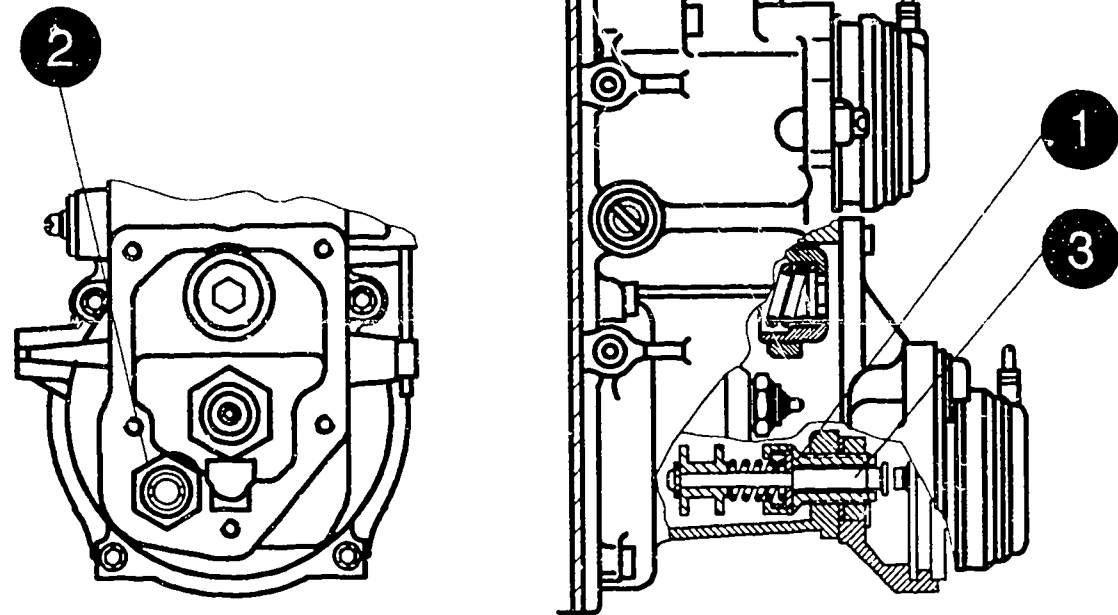

KMK00966

- 1 = Spring retainer, full-load control-rod travel (pump with ARD)
- 2 = Lock nut
- 3 = Drive hub

Set control-rod travel by way of adjusting screw for full-load control-rod travel or by turning spring retainer.
Check delivery.

If delivery is not attained, correct control-rod travel within tolerance.
I M P O R T A N T
Tightening torque of lock nut 35...40 Nm
If torque is not complied with, drive hub ends up in governor housing and causes total destruction

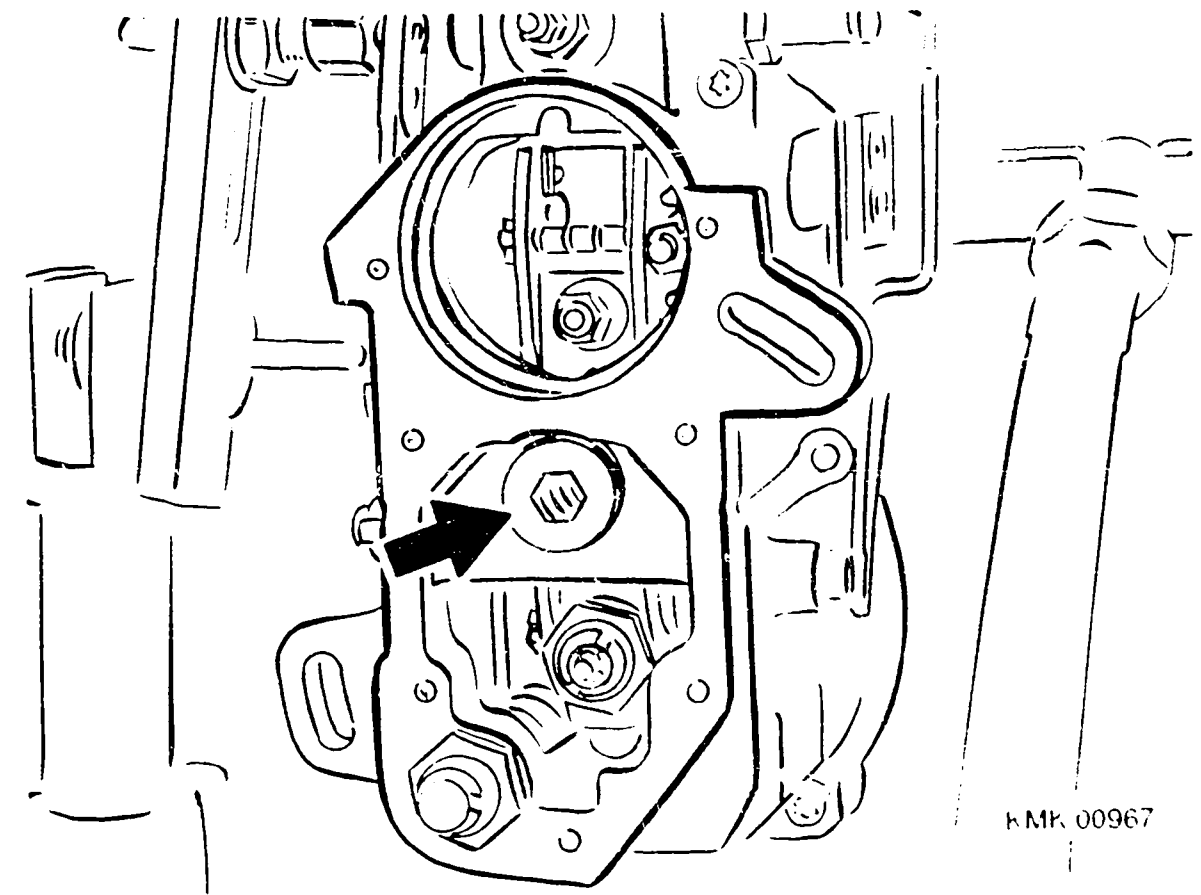

KMK 00967

Arrow = Threaded sleeve

ADJUSTING FULL-LOAD SPEED REGULATION
* Test section "UPPER RATED SPEED"

Note: There is no hexagon nut for securing threaded sleeve if ELR/ARD components are attached.

Operate fuel-injection pump at 1st speed indicated on test-specification sheet.

Screw out threaded sleeve until stated control-rod travel is obtained.

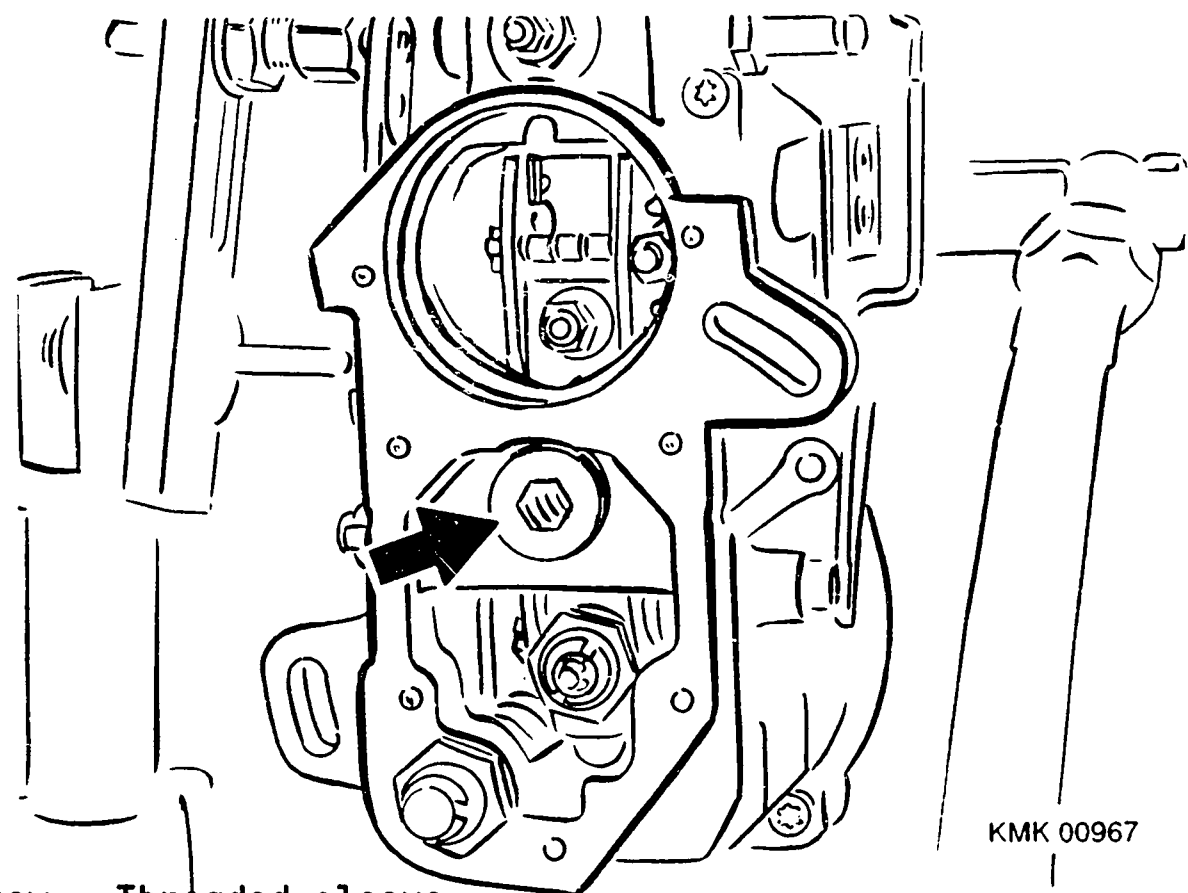

Arrow = Threaded sleeve

CHECKING HIGH IDLE

Operate fuel-injection pump at indicated speed and measure delivery.
 Delivery as per test-specification sheet must be attained.

Effect correction at threaded sleeve.

The control-rod-travel tolerance (SECTION "UPPER RATED SPEED, 1ST SPEED INDICATION) must always be complied with. Tighten hexagon nut (if fitted) to 25...45 Nm.

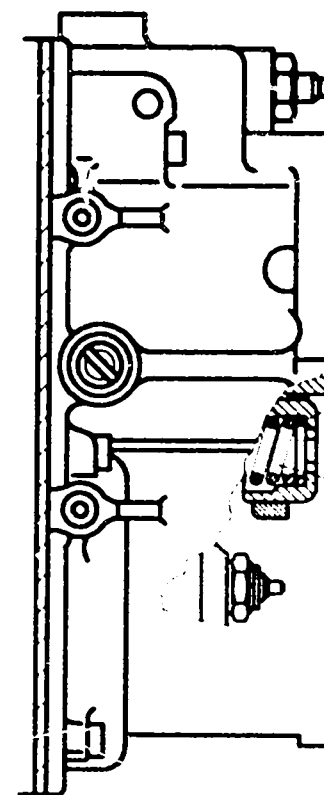

1 = Governor spring
 2 = Shim

If the required delivery is not attained without exceeding the control-rod-travel tolerance, check freedom of movement of governor; replace governor spring.

Note:
 Install teflon-coated side of plain washer facing retainer.
 After replacing governor spring, repeat governor adjustment as of Coordinate C21.

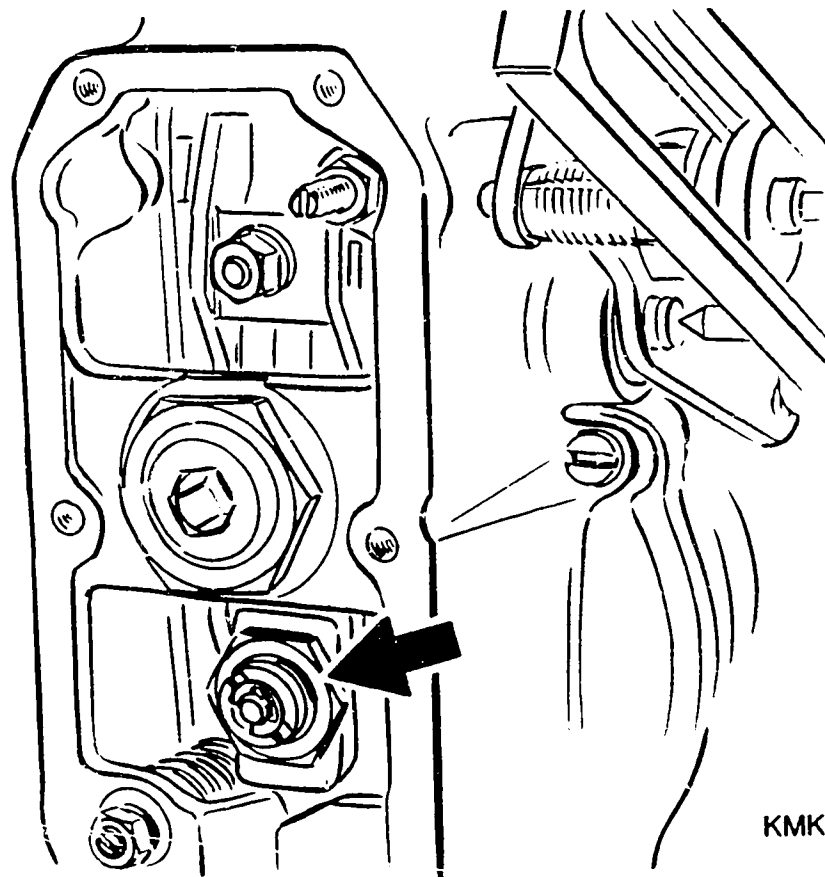

KMK 00940

Arrow = Torque-control retainer

CHECKING SLIDING-SLEEVE POSITION

* Test section, upper rated speed
2nd speed indication

Operate fuel-injection pump in accordance with test-specification sheet.
Control-rod travel as per test-specification sheet must be attained.
Correct slight deviations (± 0.3 mm) by adjusting torque-control retainer.

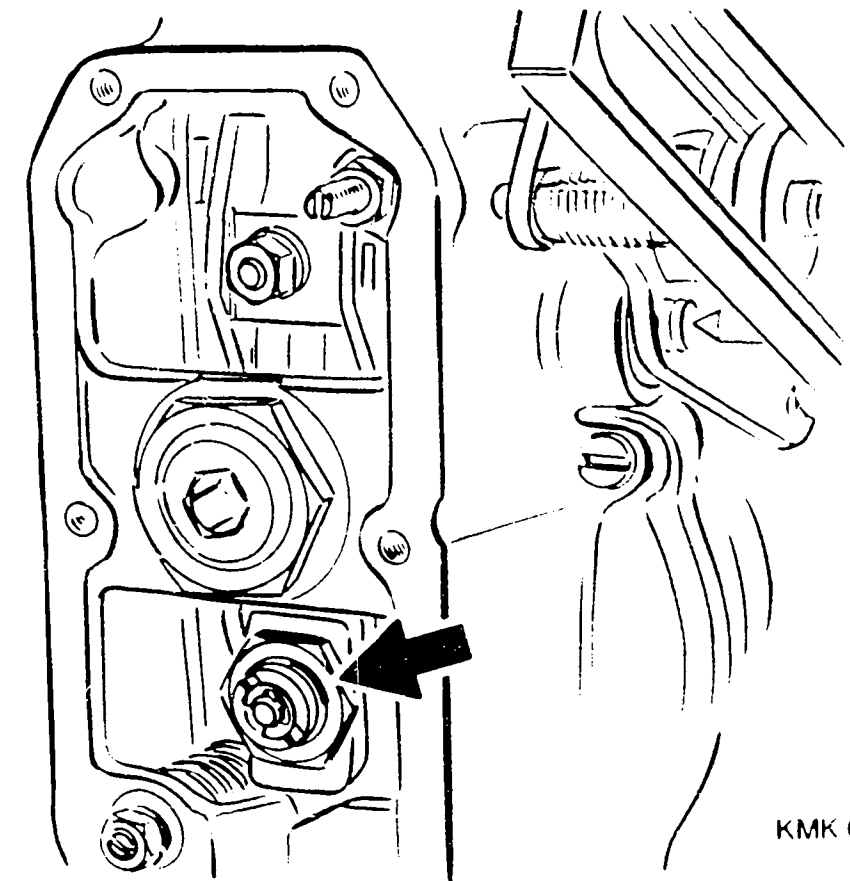

KMK 00940

Arrow = Spring retainer (torque-control retainer)

CHECKING TORQUE-CONTROL PROFILE

* Section "TORQUE CONTROL AND FUEL-DELIVERY CHARACTERISTICS"

Operate fuel-injection pump at corresponding speeds.
Check control-rod travels on dial indicator.
Check delivery in accordance with Section "FUEL-DELIVERY CHARACTERISTICS" at same speed.

Renew spring retainer (torque-control retainer) in the event of deviations.

After replacing spring retainer, repeat governor adjustment as of Coordinate C21.

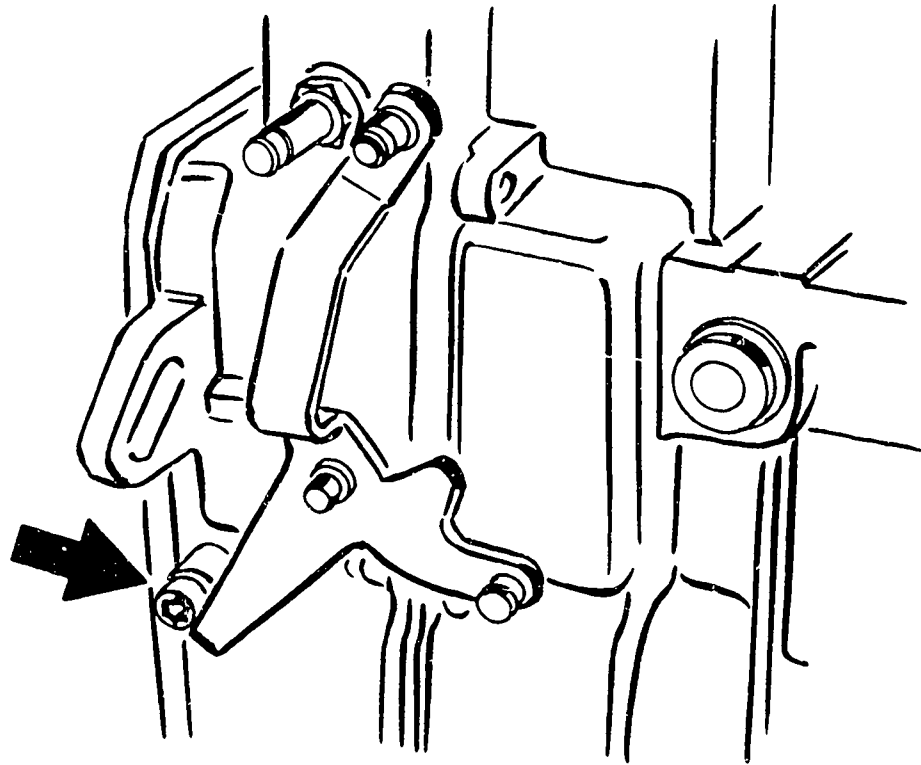

KMK 00965

Arrow = Full-load stop

MEASURING STARTING CONTROL-ROD TRAVEL AND DELIVERY

Position control lever of governor against full-load stop (head of hexagon-socket-head cap screw on governor-control-lever side) and fix.

Operate fuel-injection pump and check control-rod travel on dial indicator.

Measure delivery at same speed.

Check adjustment of full-load control-rod travel in the event of deviations.
Check freedom of movement of control rod (e.g. catching of control rod in oblique position).

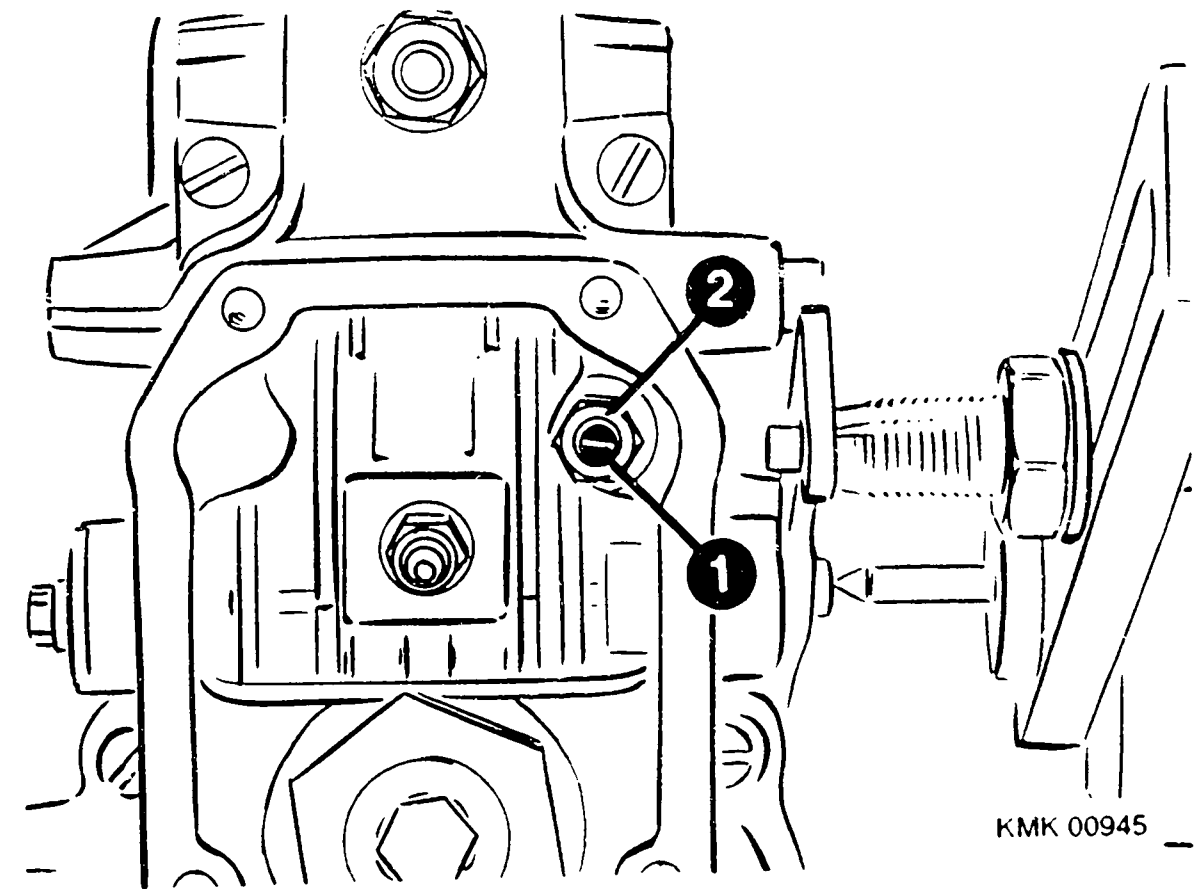

KMK 00945

1 = Idle stop screw

ADJUSTING POSITION OF IDLE CONTROL LEVER

Operate fuel-injection pump at stated speed.

Loosen control lever of governor.

After loosening hexagon nut, screw in idle stop screw such that control-rod travel as per test-specification sheet is obtained.

The resultant control-lever deflection must be within the prescribed control-lever tolerance as indicated in Section "Lower rated speed".

If prescribed control-lever position is not obtained, correct set control-rod travel within permitted control-rod-travel tolerance.

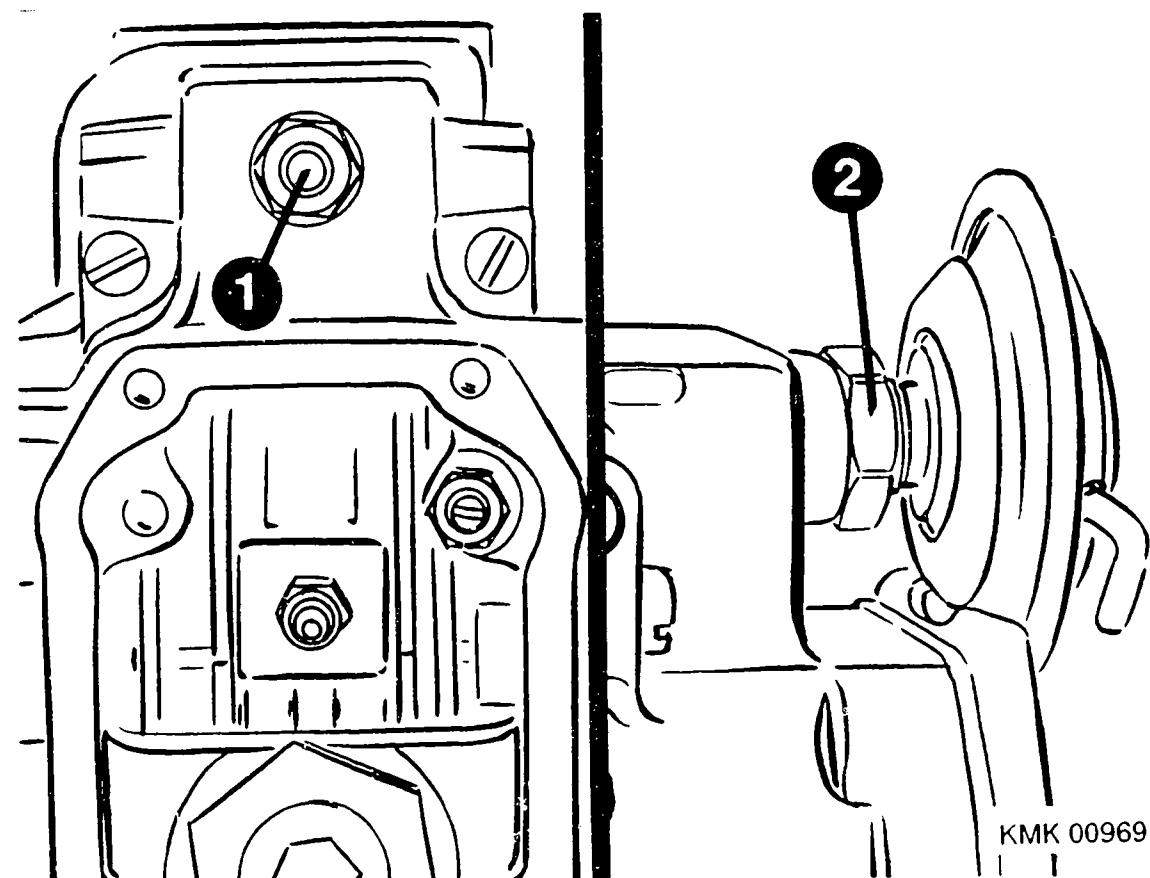

1 = Idle adjusting screw
 2 = Pneumatic idle increase (PLA)

ADJUSTING IDLE CONTROL-ROD TRAVEL AND MEASURING DELIVERY
 * Section "Lower rated speed"

Position control lever against idle stop.
 Operate fuel-injection pump at prescribed speed.
 Loosen hexagon nut of idle adjusting screw or PLA unit.
 Screw in PLA unit or idle adjusting screw until stated control-rod travel is obtained.

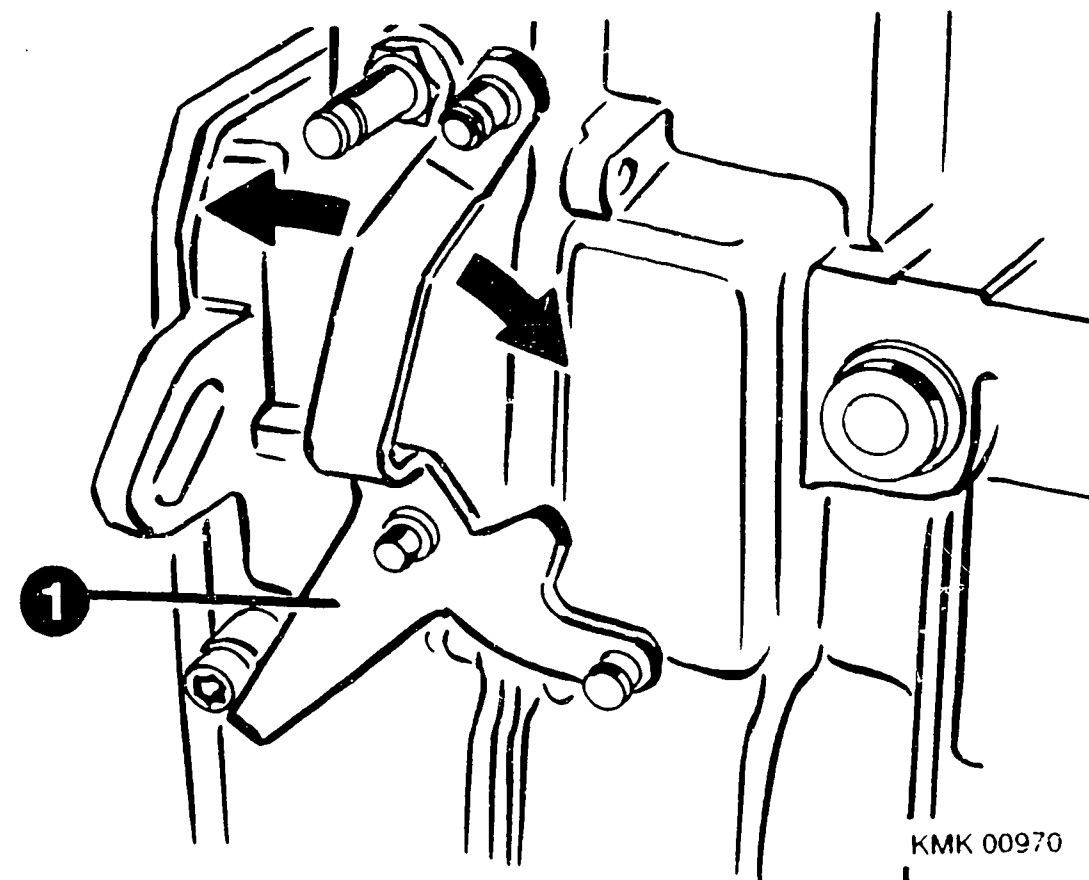

1 = Control lever

Loosen control lever and move it back and forth.
 Fix control lever in idle position.

Set control-rod travel must be re-attained.
 Repeat adjustment in the event of deviations.

Operate fuel-injection pump at idle speed and measure delivery.
 In the event of deviations, correct idle control-rod travel within permitted tolerance

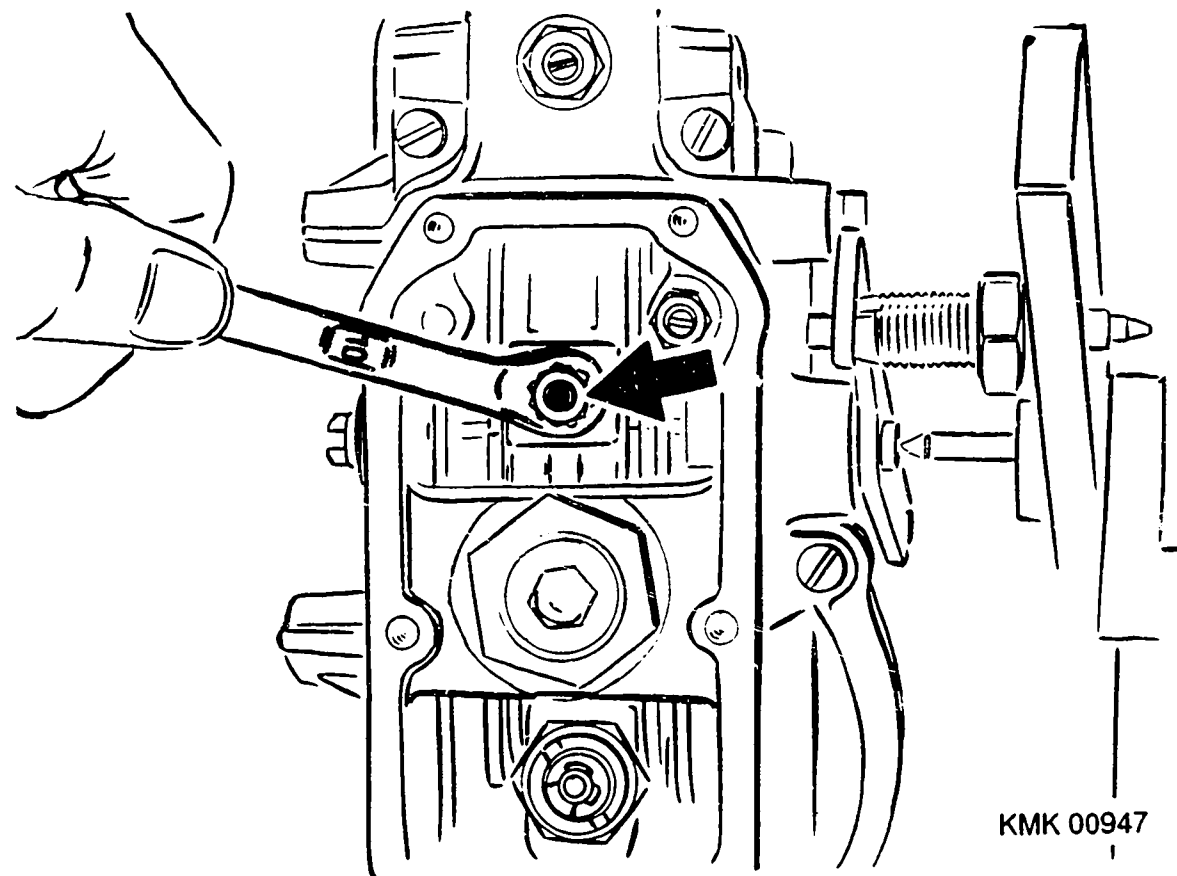

Arrow = Lock nut

ADJUSTING IDLE AUXILIARY SPRING

Operate fuel-injection pump.
Position control lever against idle stop.

Screw lock nut in direction of governor housing until prescribed control-rod travel is attained.
Loosen control lever whilst maintaining set speed and move it back and forth once.
Fix control lever in idle position again.
Set control-rod travel must be re-attained.

CHECKING POPPET CONTROL-ROD-TRAVEL PROFILE POINT

* Section "Lower rated speed"
3rd speed indication

Operate fuel-injection pump. Control-rod travel must be attained with speed tolerance.

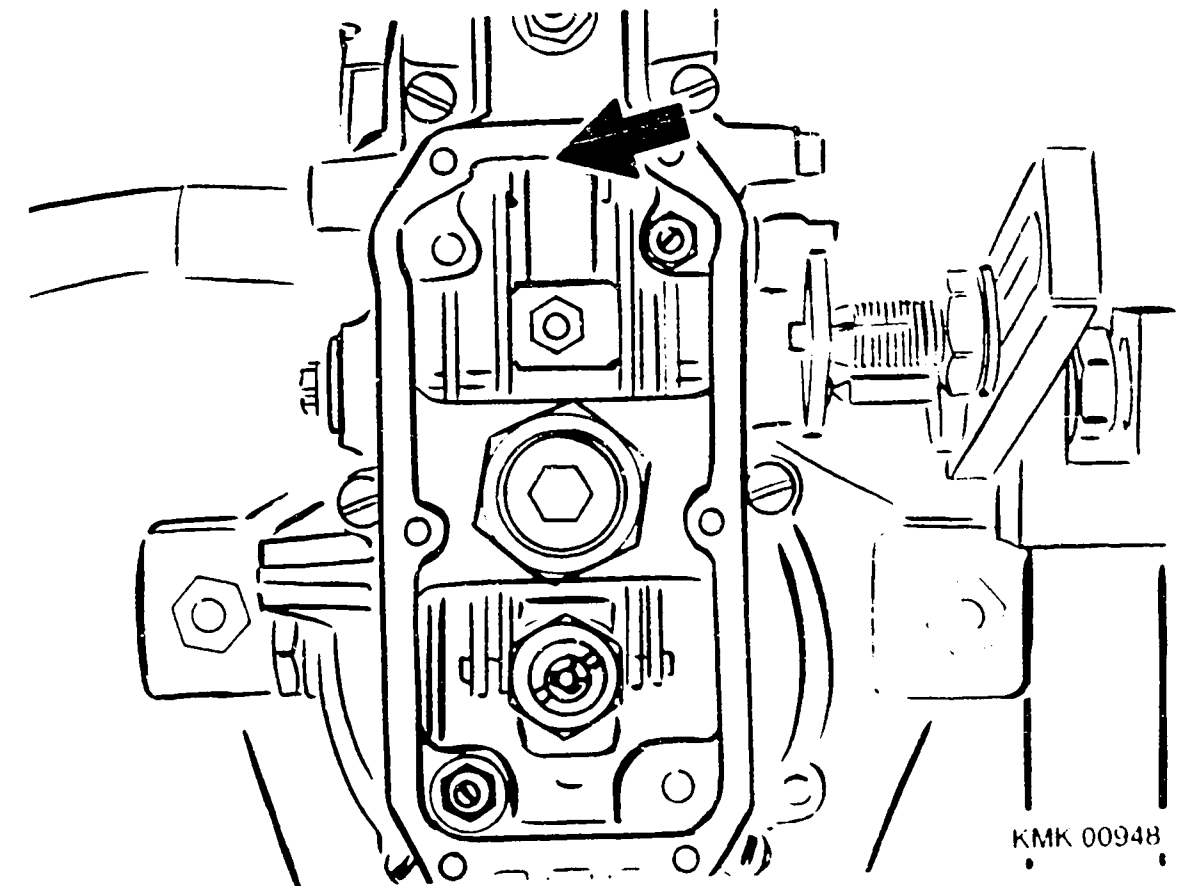

Arrow = Leaf spring

CHECKING LOAD TAKE-UP

* Section "Lower rated speed"
Testing: 1st speed indication

Use speed as per test-specification sheet.

Check control-rod travel on dial indicator.

In the event of deviations from set value, check governor linkage for freedom of movement.
Renew leaf spring if necessary.

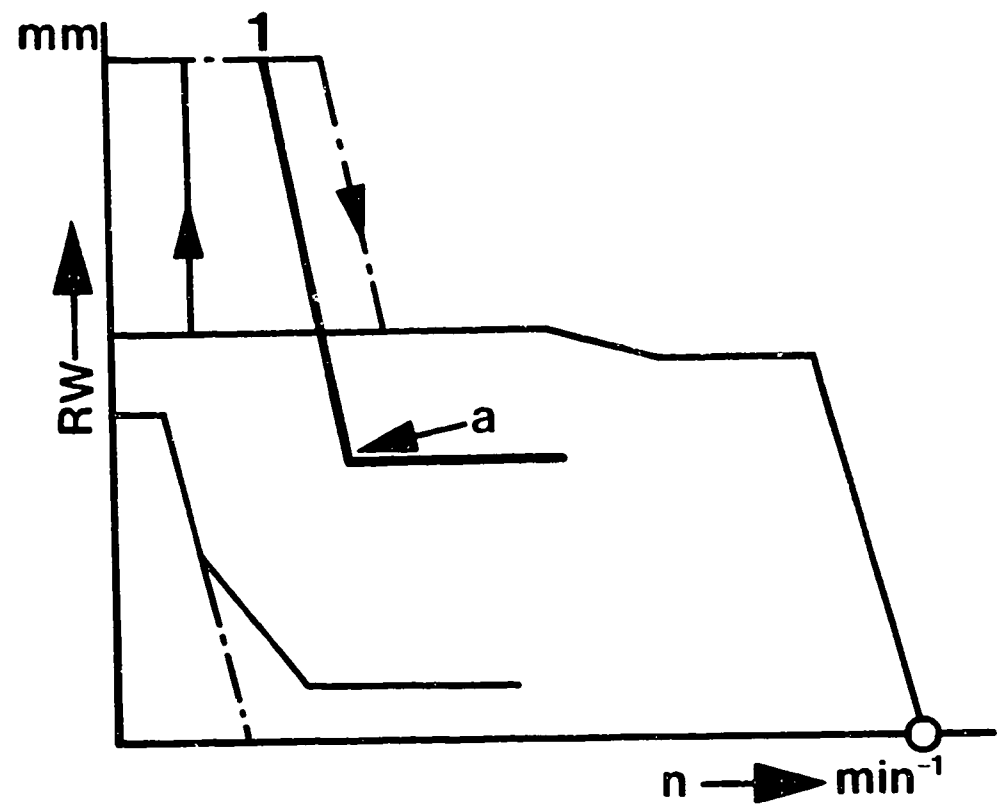

KMK 00949

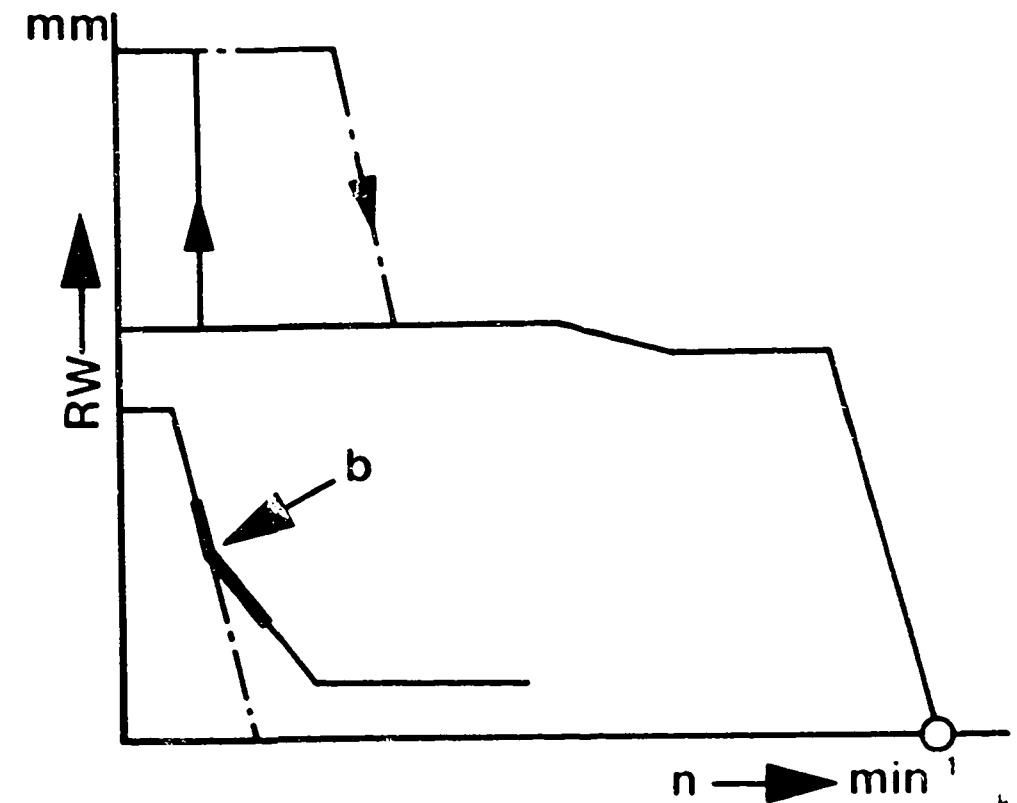

KMK 00950

RW = Control-rod travel
 n = Fuel-injection-pump speed
 1 = Switching point

RW = Control-rod travel
 n = Fuel-injection-pump speed

IDLE AUXILIARY SPRING SHUTOFF
 (Checking poppet shutoff)

* Section "Remarks"

Note:
 Refer to test-specification sheet for differing data

Fix control lever of governor in accordance with indication on test-specification sheet.
 Uniformly increase drive speed of fuel-injection pump from "0" min^{-1} to speed as per test-specification sheet.

A maximum change in control-rod travel of 0.2 mm at 1000 min^{-1} is permitted following switching point from starting control-rod travel to part-load control-rod travel (point "a" on upper governor curve).

Set control lever to second control-lever value.
 Control-rod-travel reduction must be more than 0.2 mm after switching point from starting control-rod travel (point b).

Correct settings by way of adjusting screw for poppet shutoff.
 To do so, remove governor cover.

If no correction is necessary, continue as of Coordinate D17.

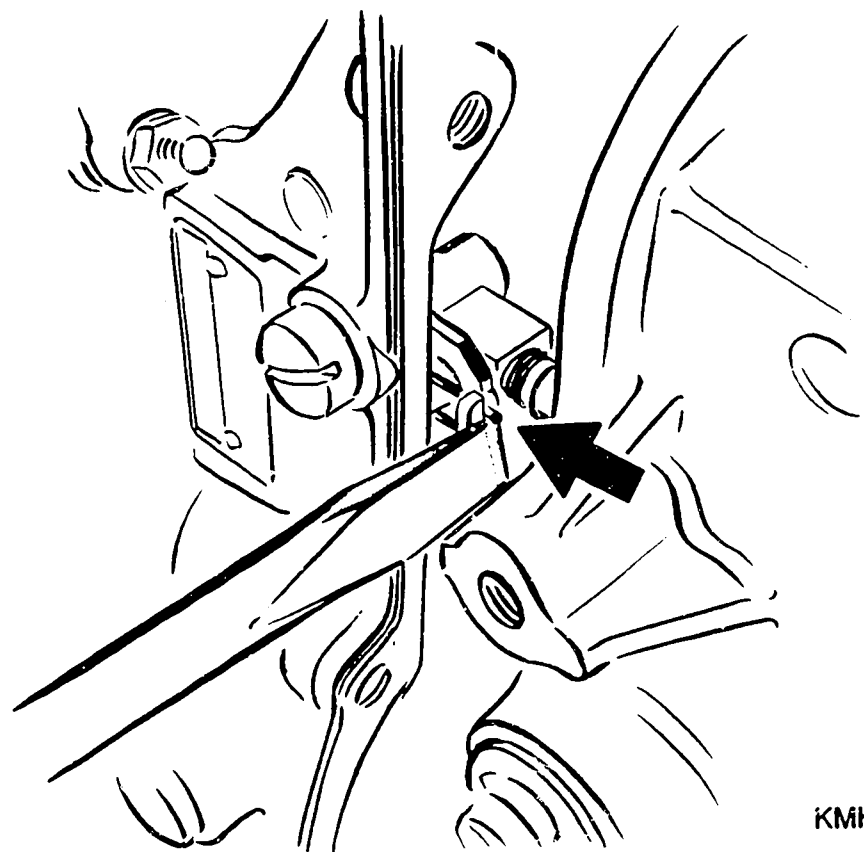

KMK 00951

CHECKING IDLE AUXILIARY SPRING SHUTOFF

Remove setting device from control lever.
Remove fastening screws of governor cover.

Pull back governor cover.
Disengage clamping spring from connecting pin of fulcrum lever (arrow).
Pull fulcrum lever out of control rod.
Remove governor cover from pump housing and clamp it in position in vice (use protective jaws).



KMK 00952

Arrow = Idle auxiliary spring

Position control lever against idle stop.
Use depth gauge to measure distance between governor cover and idle auxiliary spring (measurement point at end of spring).
Note down dimension "1".

Position control lever against full-load stop and hold.
Measure distance between governor cover and over-compressed idle auxiliary spring.
Note down dimension "2".
Subtract dimension 1 from dimension 2.
The difference between the two dimensions must correspond to the set value
Basic dimension 1.60...1.65 mm with control lever 47°
(add 0.13 mm for every change in control-lever position by 1 degree) e.g. 49 degrees = 1.86...1.91 mm

Correct dimensions if necessary.

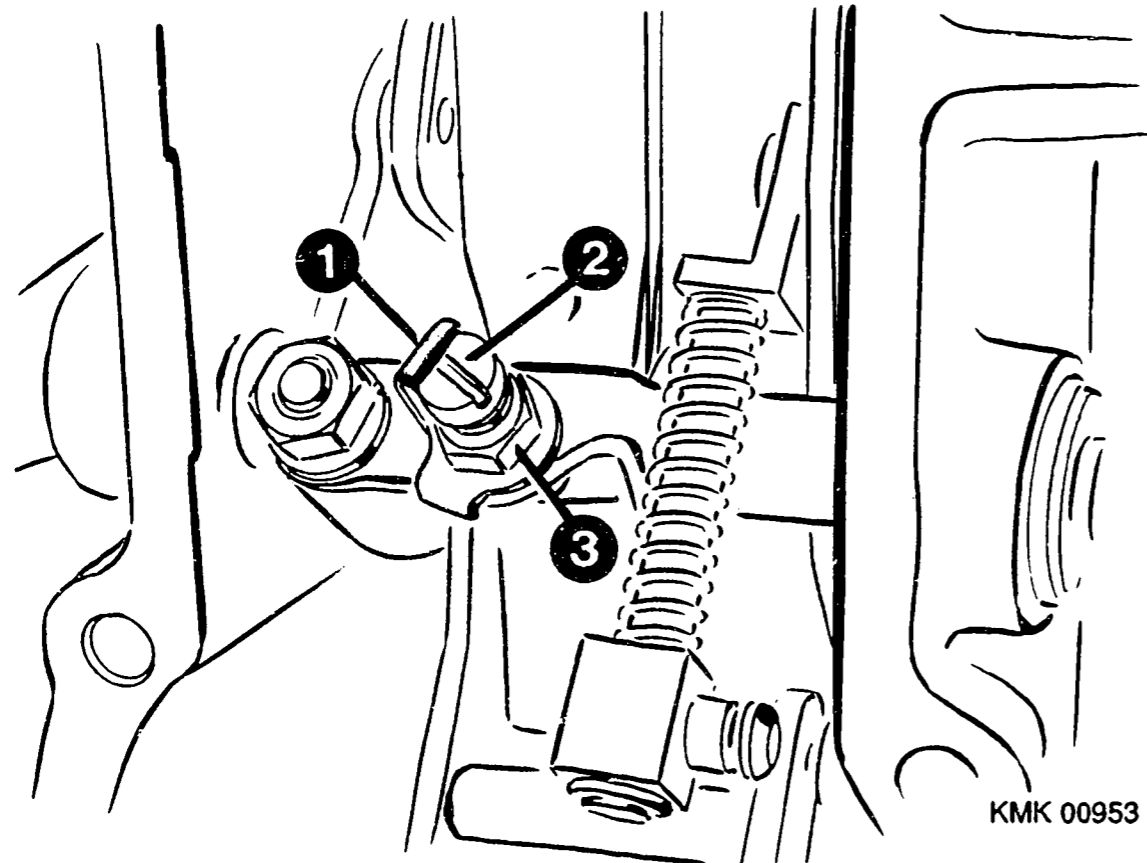

KMK 00953

- 1 = Tab washer (if provided)
- 2 = Adjusting screw
- 3 = Hexagon nut

Bend open tab washer (if fitted).
Loosen hexagon nut.

Screw out adjusting screw; in doing so, counter-hold hexagon nut if necessary.

Degrease new adjusting nut with hexagon nut prior to assembly and coat thread with Loctite 601 (green).

Fit adjusting screw with lock nut.
Position control lever of governor against idle stop and hold.

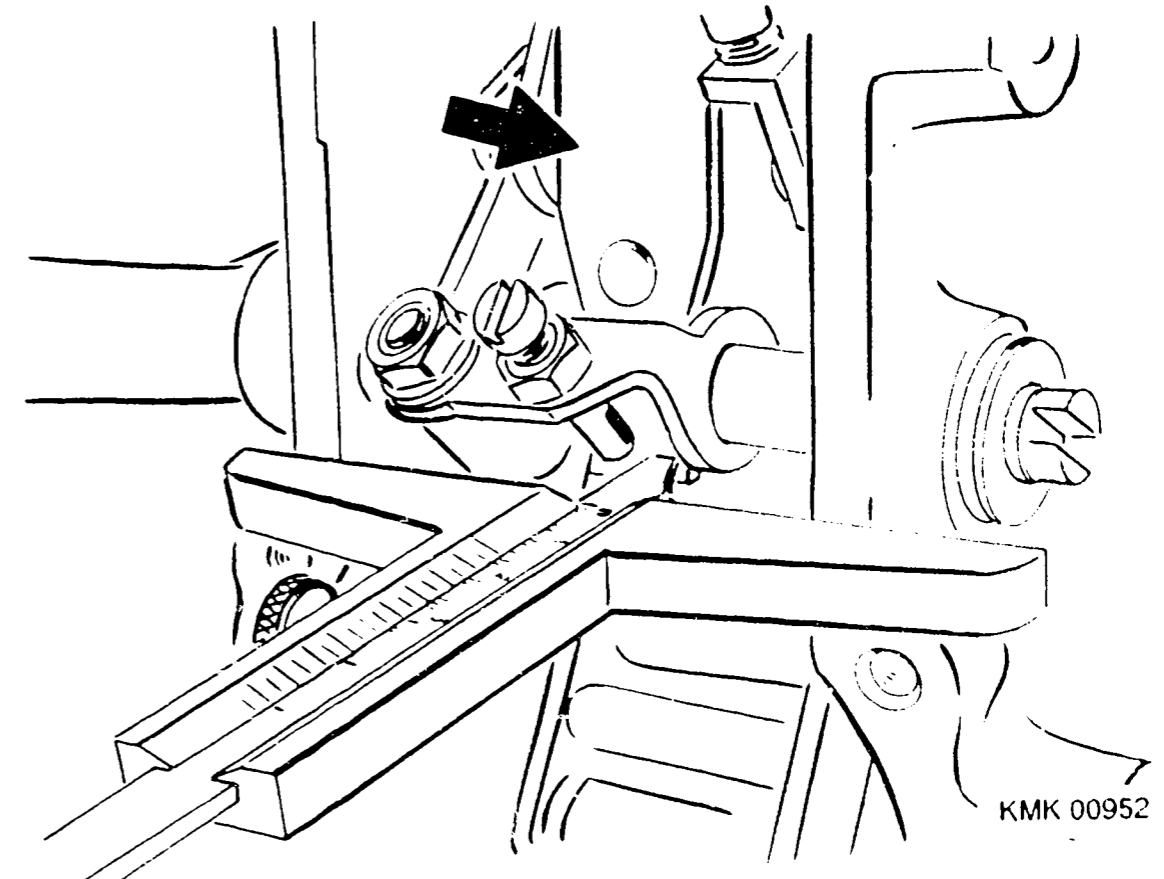

KMK 00952

Arrow = Idle auxiliary spring

Use depth gauge to measure distance between governor cover and idle auxiliary spring (measurement point at end of spring). Note down dimension "1".

Position control lever of governor against full-load stop. Measure distance between governor cover and over-compressed idle auxiliary spring. Note down dimension "2".

Adjust screw until difference between dimensions 1 and 2 corresponds to set value.

Basic dimension 1.60...1.65 mm with control lever 47°
(Add 0.13 mm for every change in control-lever position by one degree) e.g. 49 degrees = 1.86...1.91 mm

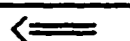

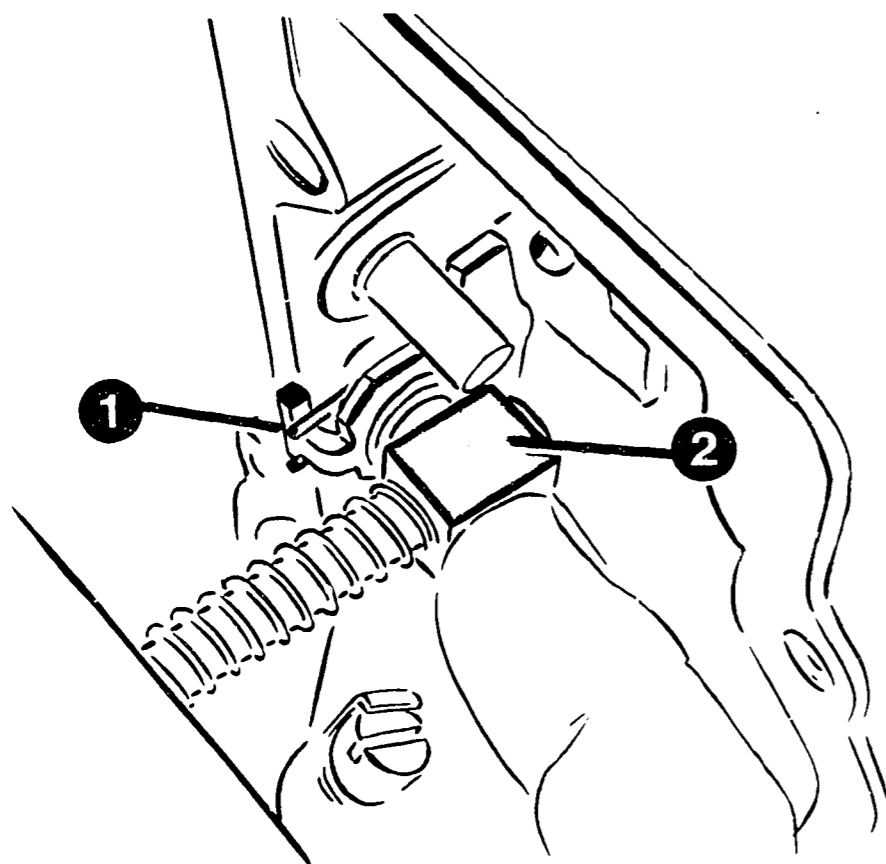

KMK 00954

- 1 = Clamping spring
- 2 = Fulcrum lever

FITTING GOVERNOR COVER

Position new sealing plate on governor cover.
Engage clamping spring (1) in control rod.

Position governor cover at lower edge of pump housing.
Insert sliding sleeve into flyweight assembly.
Engage fulcrum lever (2) in control rod.
Fit governor and tighten fastening screws to 5...7 Nm.

Attach setting device and repeat governor adjustment.

Governor adjustment as of Coordinate C21.

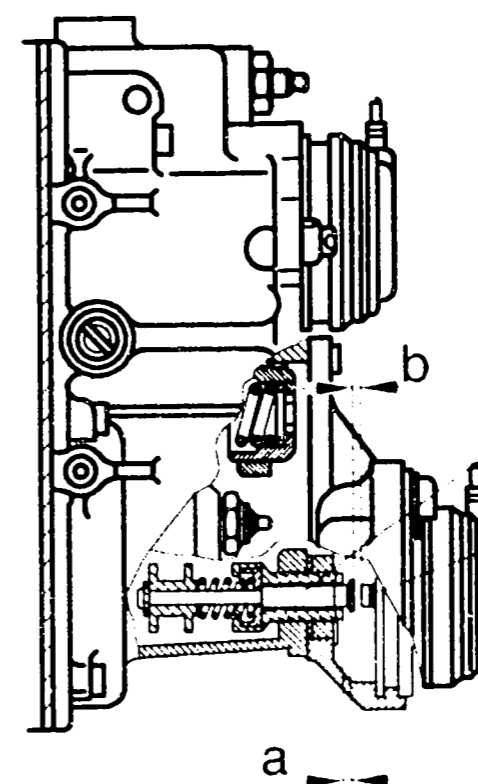

1

2

KMK00971

- 1 = Drive hub
- 2 = Adjustment pin
- a = Adjustment travel 1.5...1.7 mm
- = Control-rod travel 2.25...2.55 mm
- b = Installation dimension = 0.1...1.0 mm

ATTACHING HOUSING FOR ARD SERVO MAGNET

Continue as of Coordinate D22 if there is no ARD

Fit servo magnet.

In doing so, it must be ensured that drive hub does not press against adjustment pin of ARD.

Installation dimension, dimension "b" = 0.1...1.0 mm

Adjust by replacing adjustment pins in line with service-parts list.

If installation dimension is not complied with (e.g. less than 0.1), adjustment pin is pressing against drive hub and full-load delivery is being reduced.

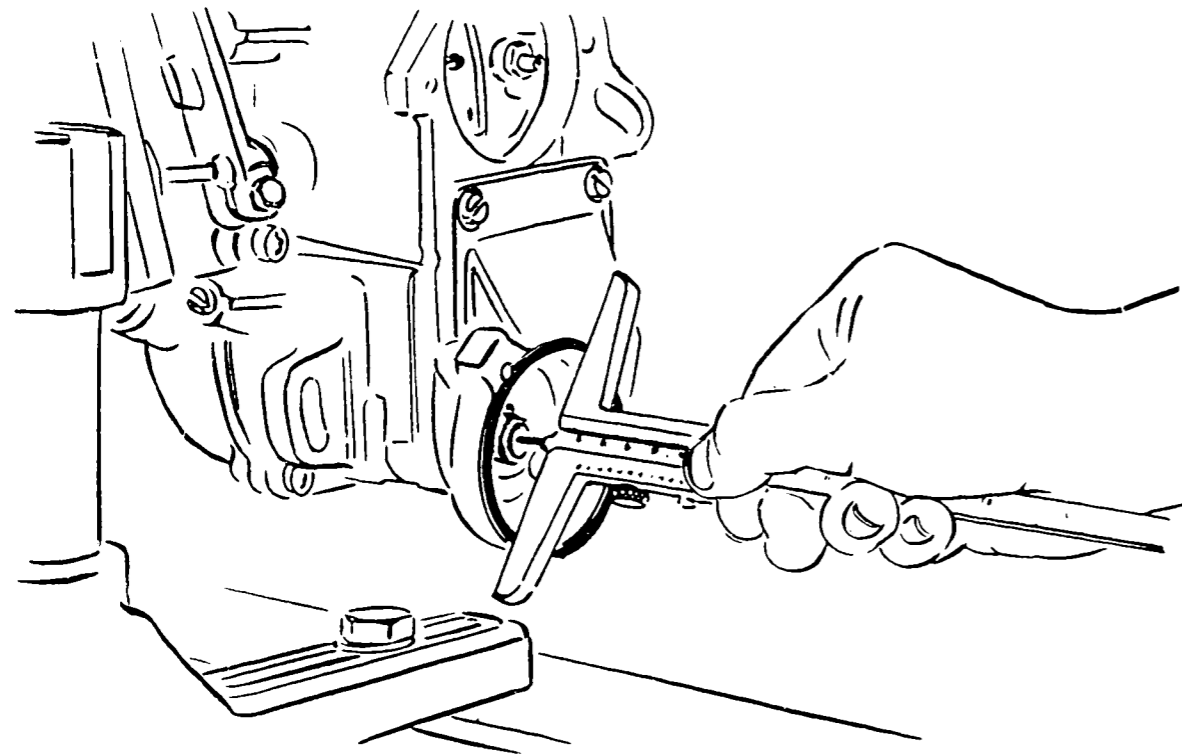

KMK 00972

SERVO-MAGNET CALIBRATION

Fit ARD housing.

Measure distance "c" between ARD housing and drive hub.
Take care not to exert excessive force on drive hub.
Note down dimension "c".

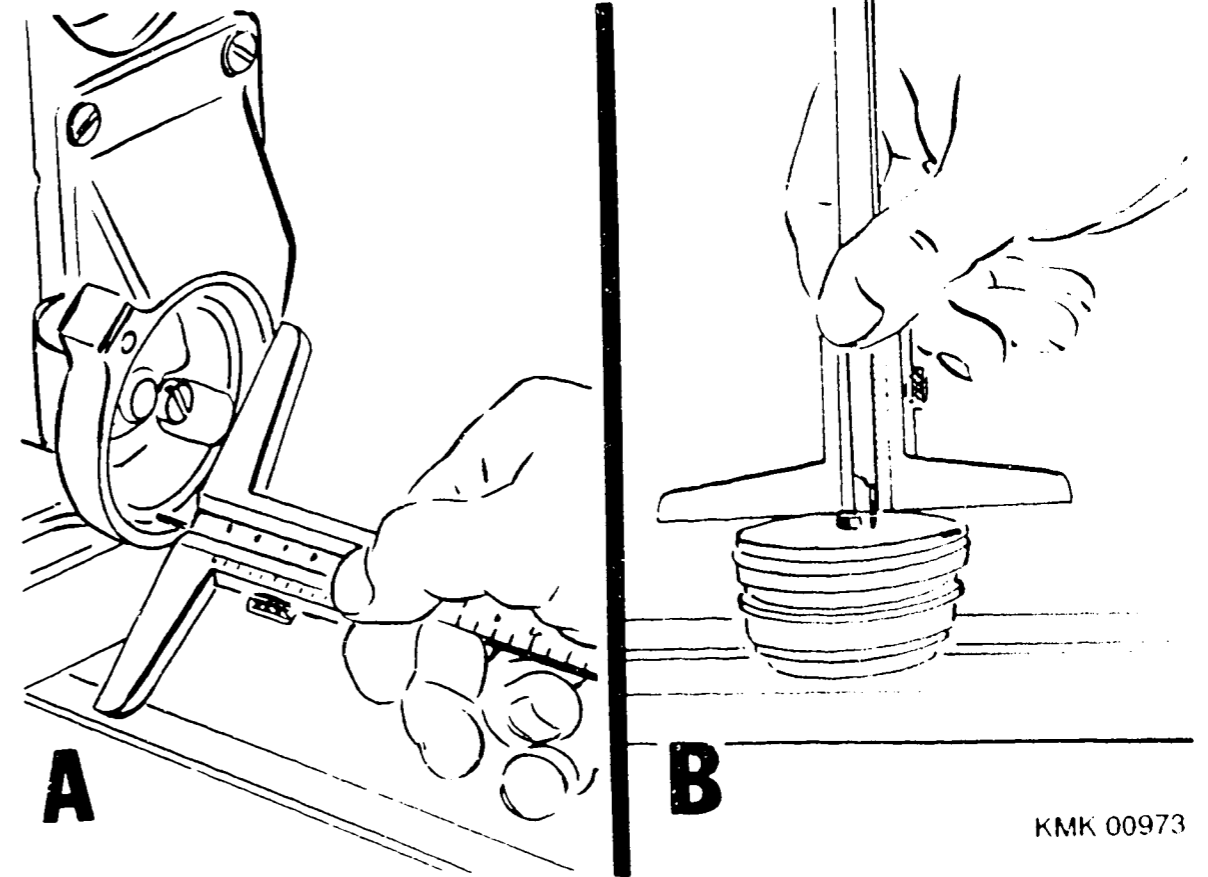

KMK 00973

Measure and note down depth of installation space "d" of ARD servo magnet (Fig. A).
Measure length of adjustment pin "e" to servo-magnet housing; note down dimension (Fig. B).

Add together dimensions "d" and "e".
Installation dimension "b" = "c" minus total dimension of "d" and "e"

Check full-load quantity again after attaching servo magnet.
Do not apply current to servo magnet in the above process.

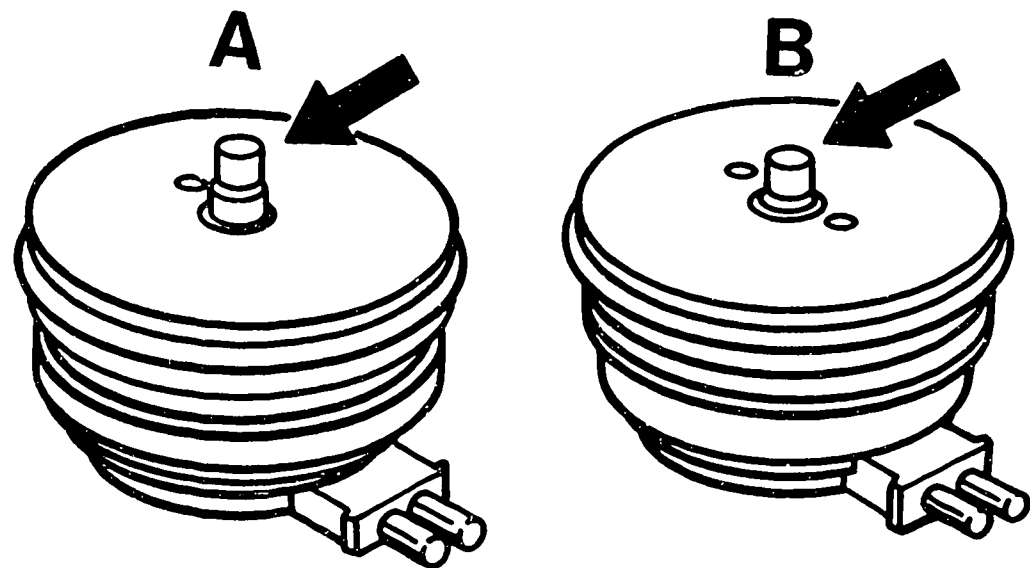

KMK 00974

A = ELR servo magnet

B = ARD servo magnet

ARD AND ELR DISTINGUISHING FEATURES

A = ELR servo magnet (red), captive adjusting pin, arrow

B = ARD servo magnet (black or grey), non-captive adjusting pin, arrow

Note:

When renewing ARD servo magnet, install old adjusting pin in new servo magnets.

This ensures that installation clearance is complied with.

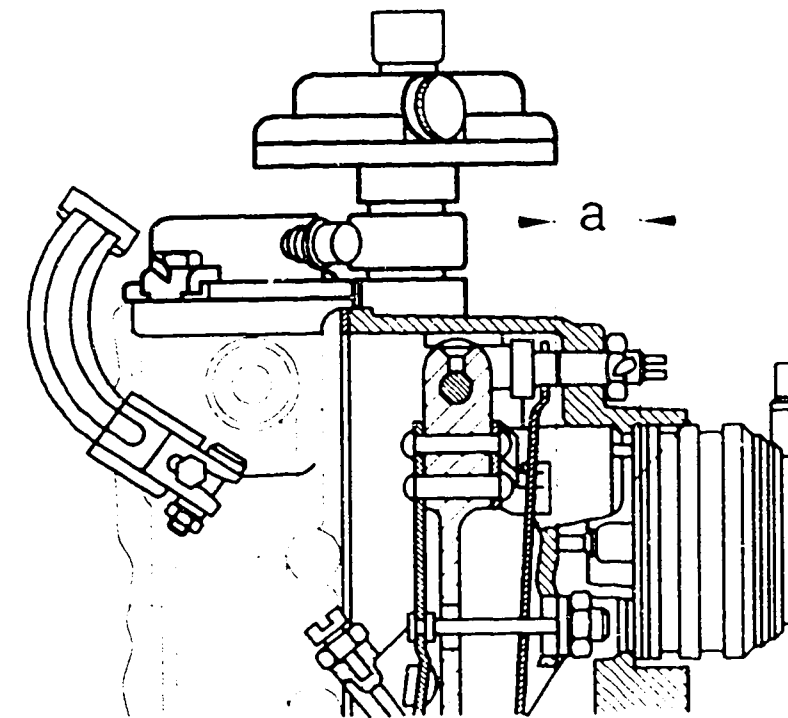

KMK00975

1 = Shims

ATTACHING SERVO MAGNET OF IDLE-SPEED REGULATION (ELR)

- * No ELR and add-on modules - continue as of Coordinate D23
- * Add-on modules present - continue as of Coordinate E28

Fit servo magnet with shims (between servo magnet and governor housing), taking care to comply with spacing "a".

Servo magnet	Spacing	Contact surface at guide lever
red	14.6...15.7	roller
black	17.7...18.8	strap

Attach servo magnet.

Apply current to servo magnet.

Measure control-rod travel and delivery.

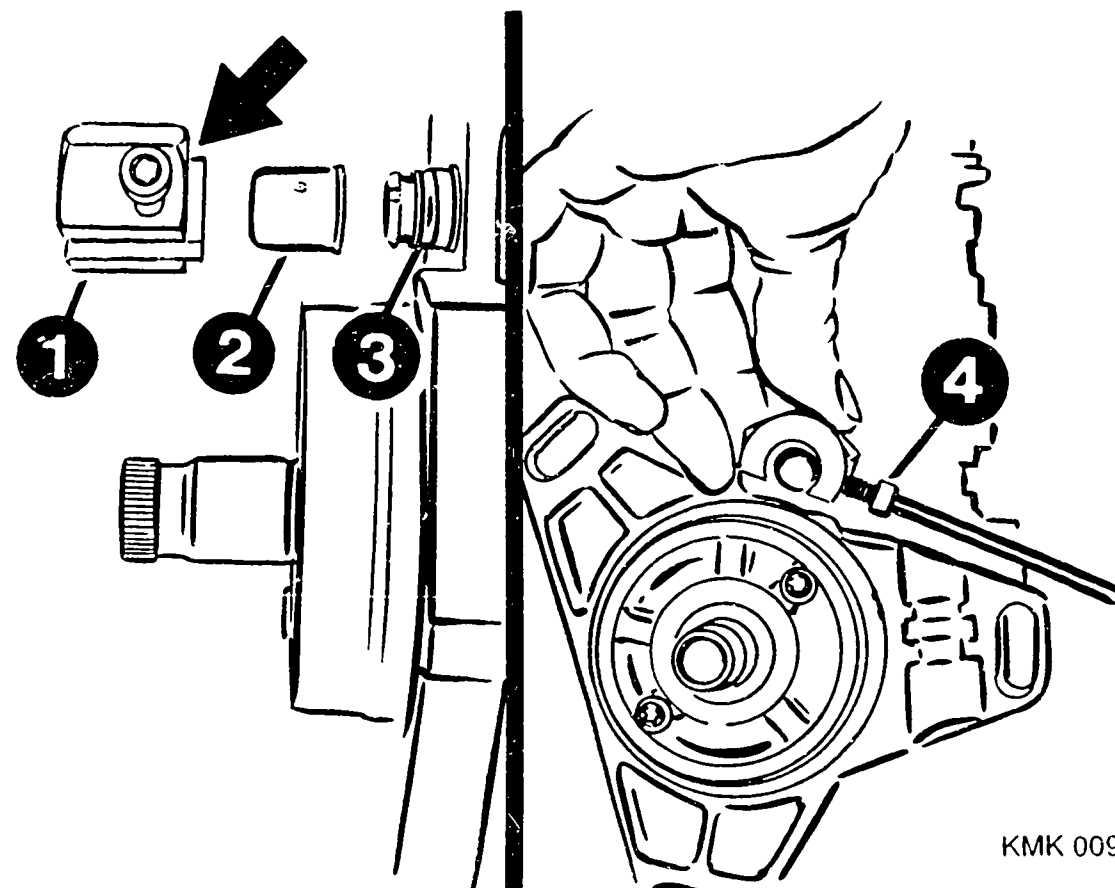

KMK 00976

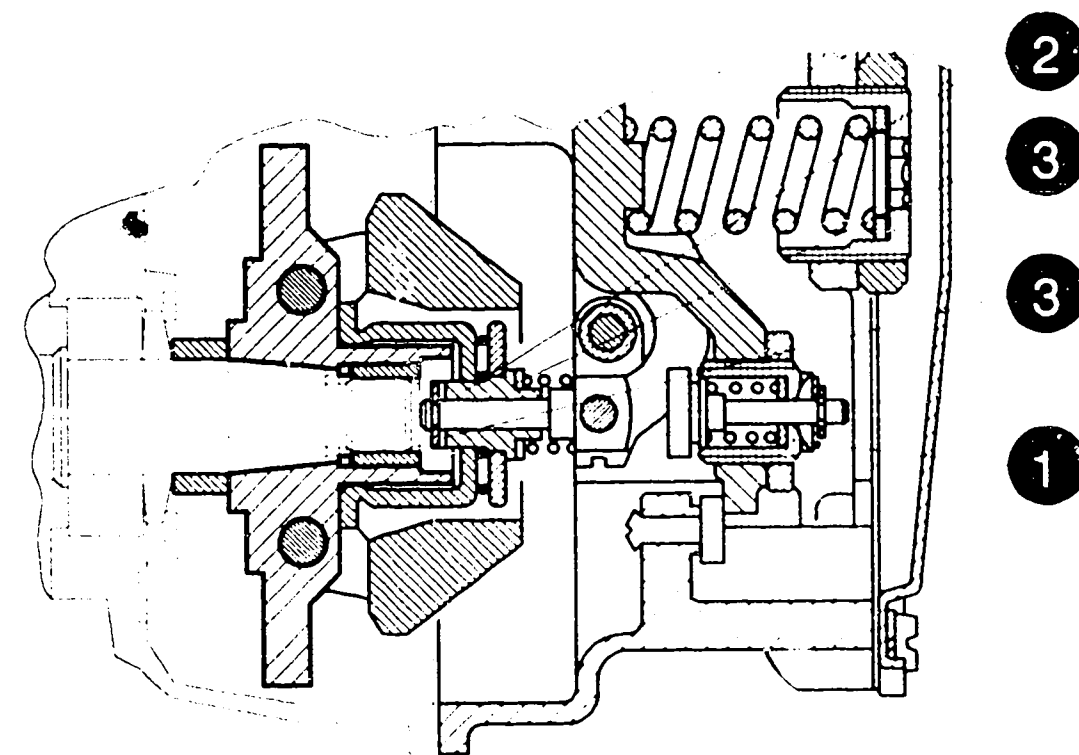

KMK00977

- 1 = Embossing tool
- 2 = Control-rod closing cap
- 3 = Control-rod guide sleeve
- 4 = Hexagon-socket-head cap screw

CONCLUDING WORK

Remove control-rod-travel measuring device.
Slip new control-rod closing cap onto control-rod guide sleeve as far as it will go.

Slip embossing tool KDEP 1635 over guide sleeve such that machined collar (arrow) makes contact with pump housing.

Screw in hexagon-socket-head cap screw until increased resistance is felt.

Check function of shutoff unit with appropriate vacuum.
Completely assemble fuel-injection pump.
Perform leak test on camshaft chamber with test cone KDEP 1565.

ADJUSTING GOVERNOR RSF II (WITH START-OF-DELIVERY SENSOR SYSTEM) AND POSITIVE/NEGATIVE TORQUE CONTROL

* Positive/negative torque control is made up of:

- 1 = Positive spring retainer (torque-control retainer)
- 2 = Negative spring retainer
- 3 = Shims

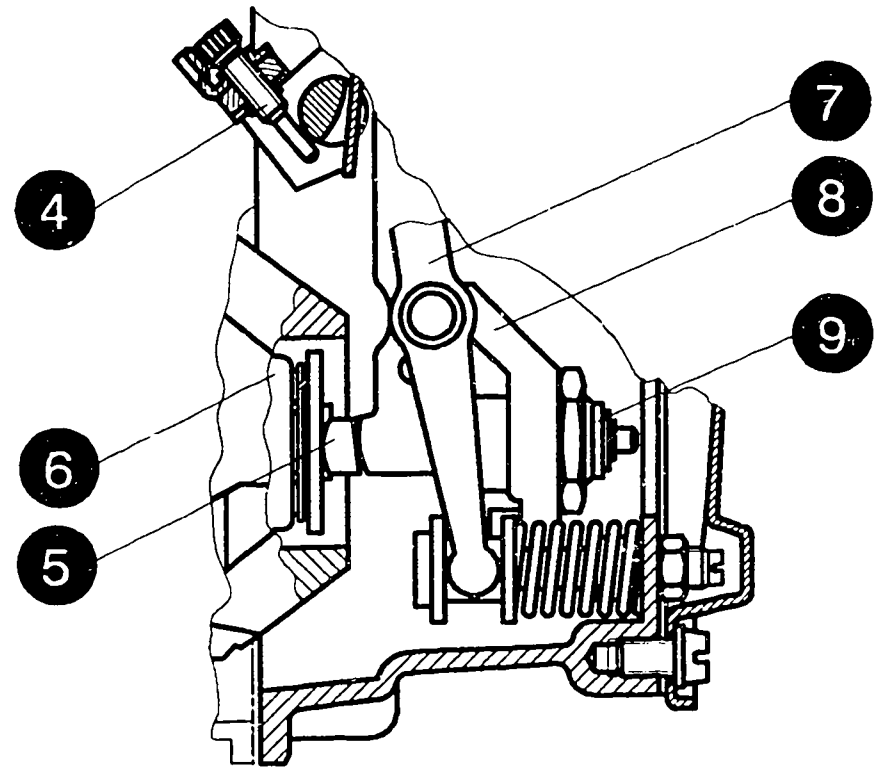

KMK00978

- 4 = Adjusting screw
(idle auxiliary spring shutoff)
- 5 = Rocker arm connected to fulcrum lever
- 6 = Sliding sleeve
- 7 = Fulcrum lever
- 8 = Tensioning lever
- 9 = Positive spring retainer (torque-control retainer)

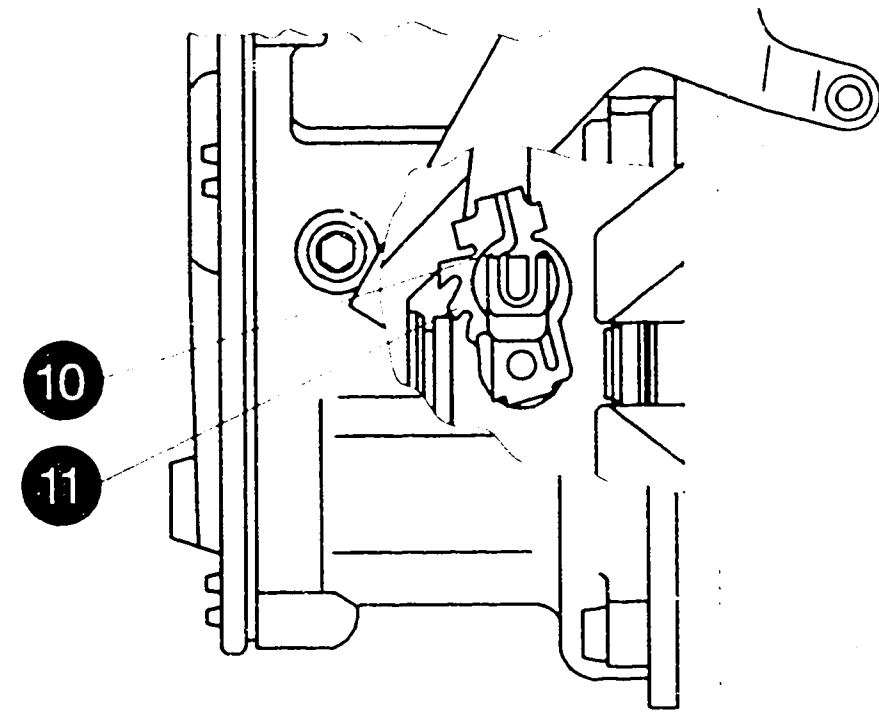

KMK00979

- 10 = Spiral spring
- 11 = Catch disc

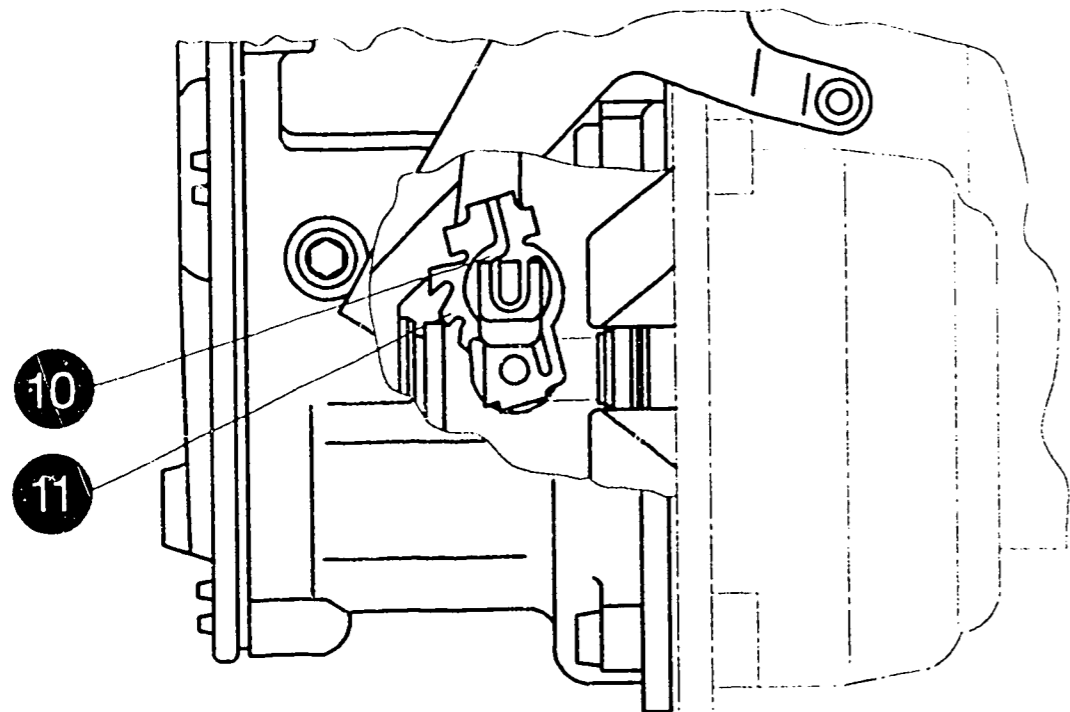

KMK00979

10 = Spiral spring
11 = Catch disc

PREPARATION

- * If fitted, remove aneroid box for:
 - Absolute boost pressure-dependent full-load stop (ALDA)
 - Ambient-pressure-dependent full-load stop (ADA).

Engage spiral spring at reverse-transfer lever in center position of catch disc.

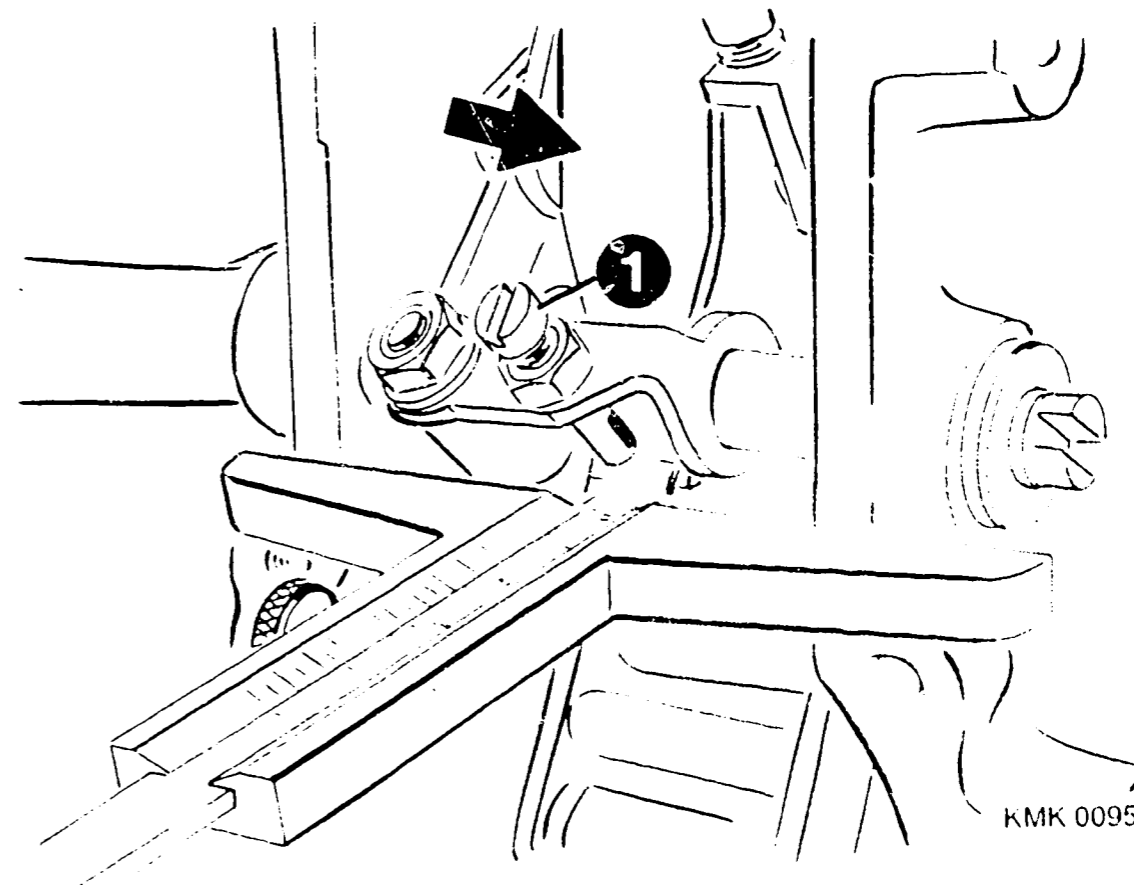

KMK 00952

1 = Adjusting screw, idle auxiliary spring shutoff

Set adjusting screw, idle auxiliary spring shutoff to set value.

Set value: 2.90...3.00 mm

Position control lever against idle stop.
Use depth gauge to measure distance between governor housing and idle auxiliary spring (arrow).
Note down dimension "1".
Position control lever against full-load stop and hold.
Measure distance from over-compressed idle auxiliary spring. Note down dimension "2".
Adjust screw until difference between dimensions 1 and 2 corresponds to set value.

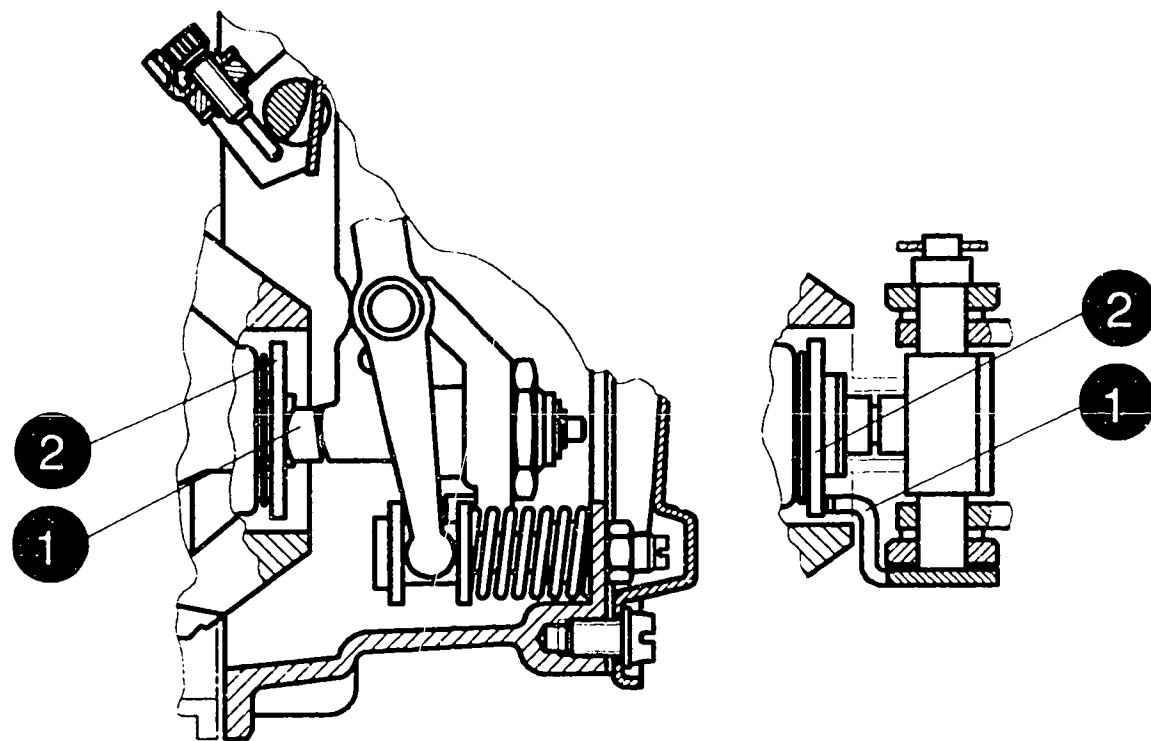

KMK00980

- 1 = Rocker arm
- 2 = Friction washer

Fit seal between governor cover and pump.

Place rocker arm in correct position behind friction washer.

Attach governor with built-in compound lever to fuel-injection pump.

Do not fit closing cover of governor.

Attach protractor to control lever so as to be stress-free.

Depending on type of test bench, attach auxiliary lever (control lever of RQV governor) if appropriate on opposite side of governor control lever.

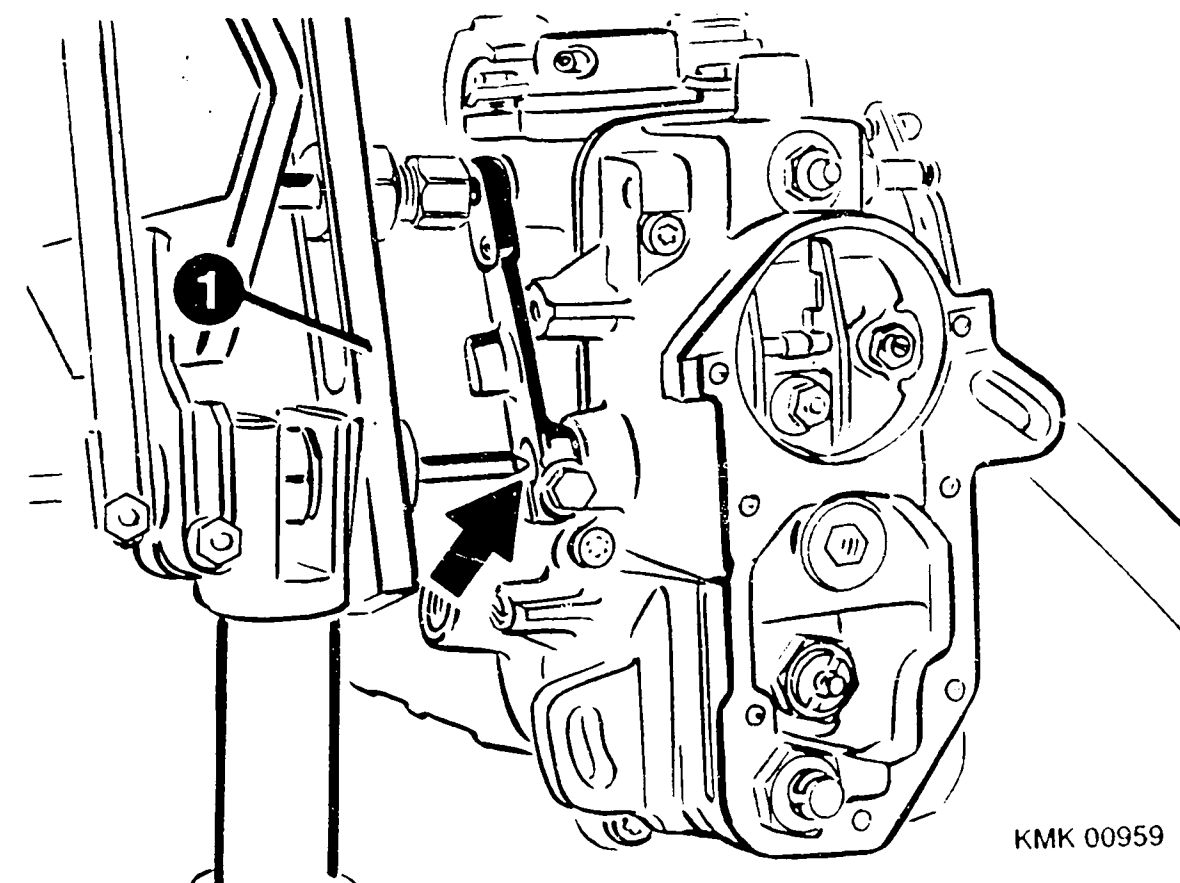

KMK 00959

- 1 = Swivelling lever

Attaching swivelling lever to control lever

Pointed pivot of angle indicator must face center of control-lever shaft (arrow).

The swivelling arm of the setting device is attached so as to be stress-free to the control lever.

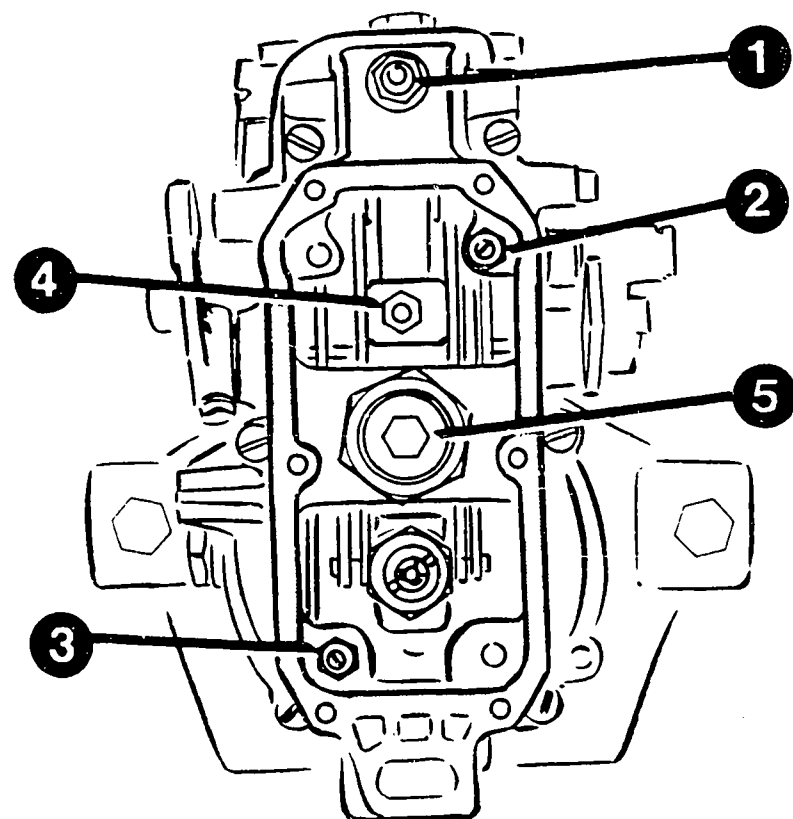

KMK 00937

- 1 = Idle adjusting screw *12.0 mm
- 2 = Idle stop screw * 7.0 mm
- 3 = Adjusting screw for full-load control-rod travel * 6.0 mm

GOVERNOR PRESETTINGS

* Measure distance between stud curvature and hexagon nut.

Note:
If there is no indication of static sliding-sleeve pre-travel on corresponding test-specification sheet, make use of governor presettings indicated above.

If sliding-sleeve pre-travel is indicated under "Remarks", all adjusting screws in governor are to be moved back.

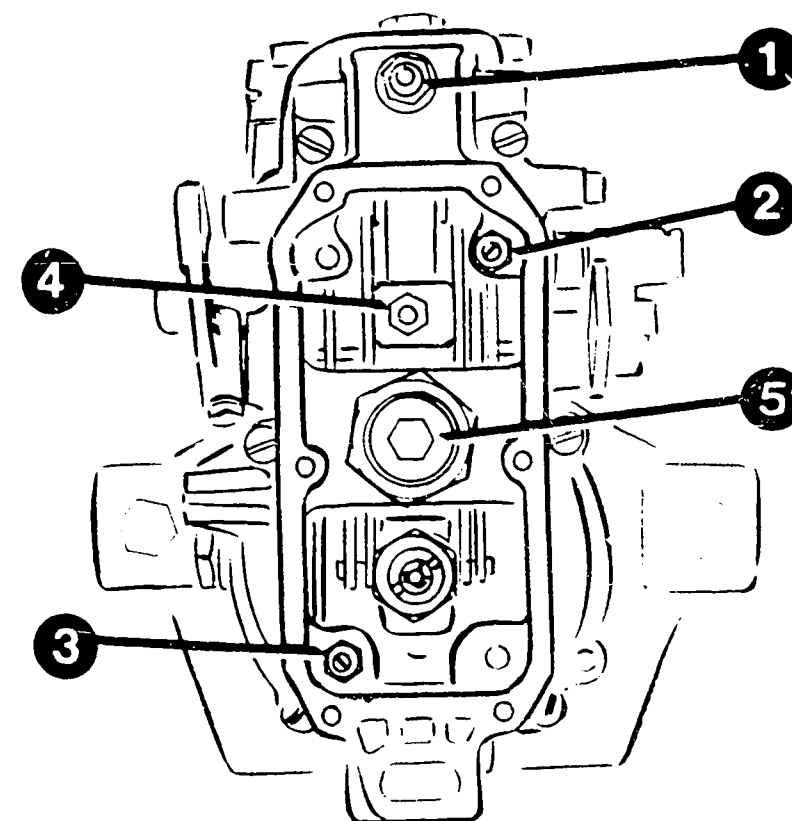

KMK 00937

- 4 = Poppet adjusting screw
- 5 = Adjusting screw, speed regulation

Screw out poppet adjusting nut as far as retainer (visible at start of thread).

Screw in threaded sleeve, full-load speed regulation until it is flush with hexagon nut.

Pour engine oil into governor and fuel-injection pump (200 cm³ in each case).
Set suction-chamber pressure on test bench to 1 bar.

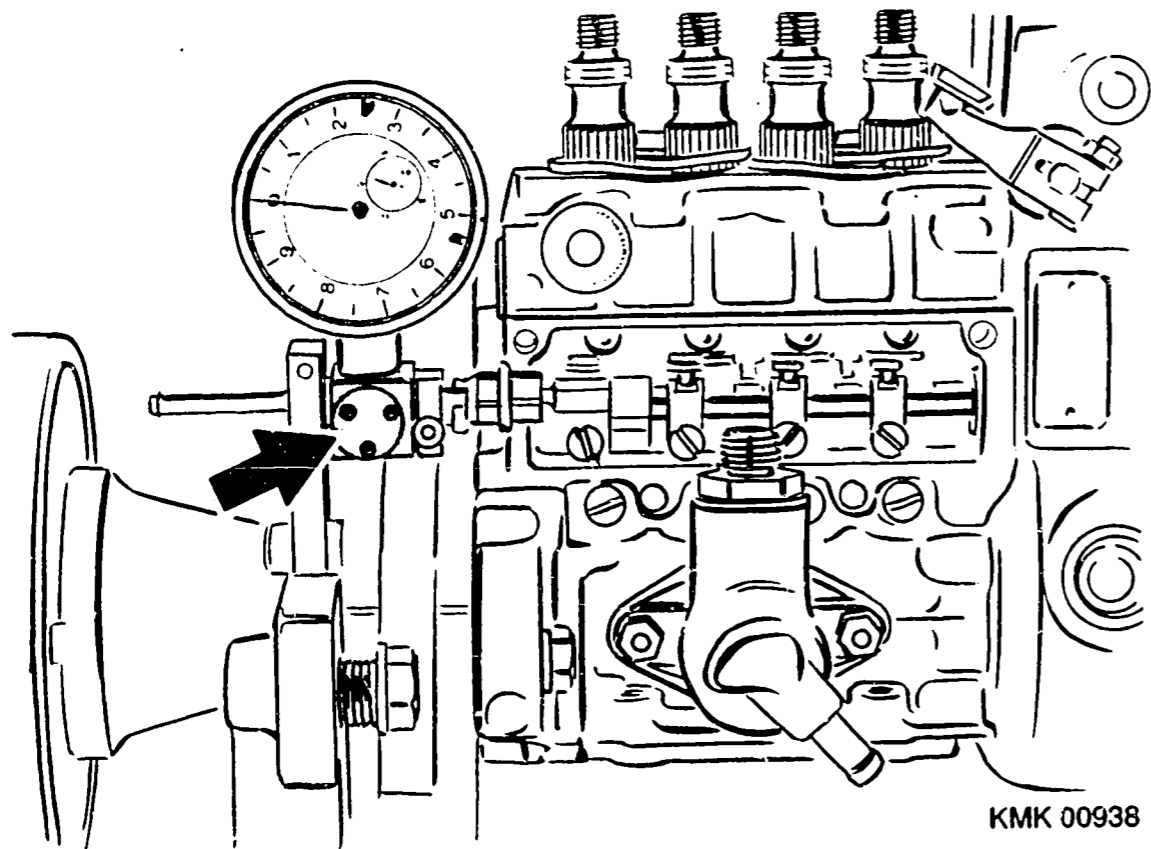

KMK 00938

Arrow = Control-rod-travel measuring device

ATTACHING AND ADJUSTING CONTROL-ROD-TRAVEL MEASURING DEVICE

Attach control-rod-travel measuring device 1 688 130 130 with accessories.

Adjust dial indicator to "0" in shutoff position of control rod.

Pull control rod from shutoff to full-load stop and check whether pointer of dial indicator reads "0" again in shutoff position.

Position control lever against full-load stop. Adjust setting device to 50° (refer to test-specification sheet).

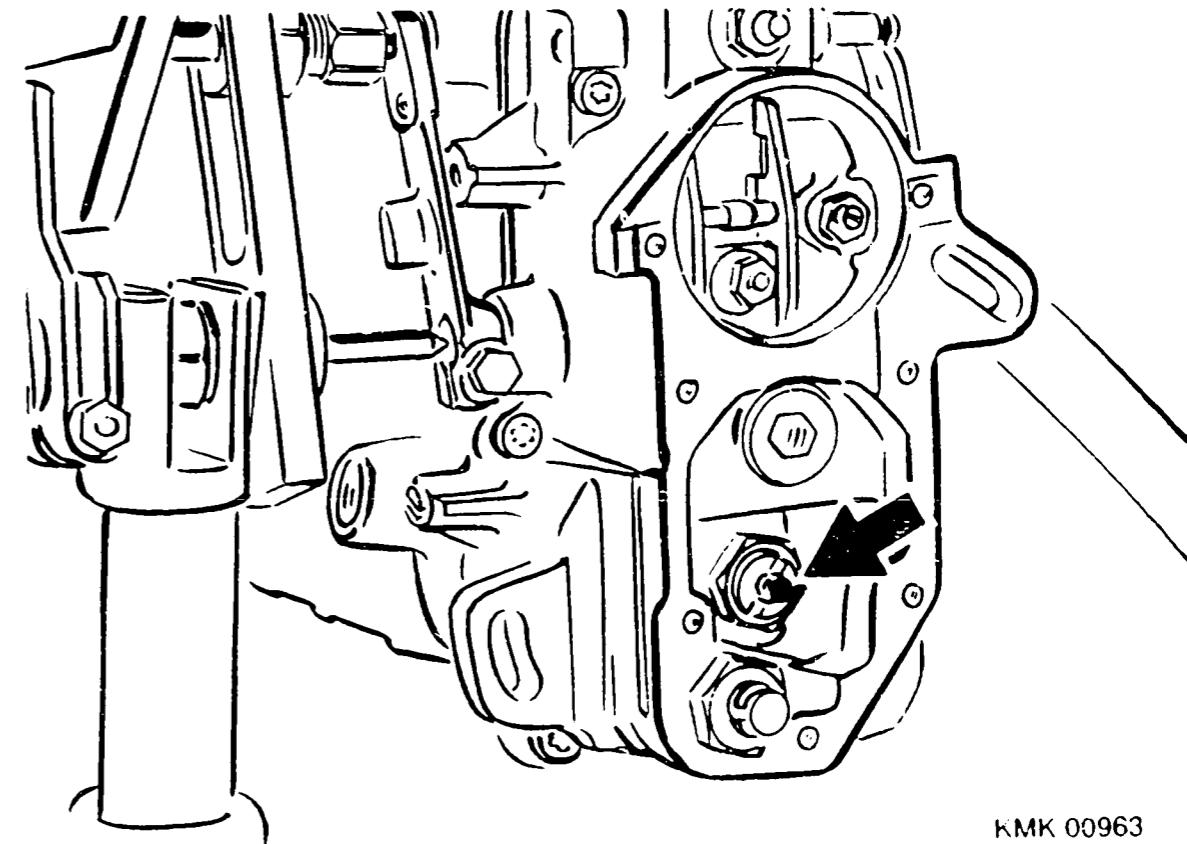

KMK 00963

Arrow = Spring retainer

STATIC IDLE-STAGE ADJUSTMENT

* Refer to back of test-specification sheet for sliding-sleeve pre-travel (mm)

If there is no indication of sliding-sleeve pre-travel, continue as of Coordinate E07

Set control lever in idle-control-lever mid-position. At speed "0", screw in spring retainer (torque-control retainer) with pin-type socket wrench KDEP 2968 until spring retainer makes contact with sliding sleeve. Do not over-compress spring retainer. Then set sliding-sleeve pre-travel indicated on test-specification sheet by screwing out spring retainer. (1 turn = 1 mm).

Continue as of Coordinate E11

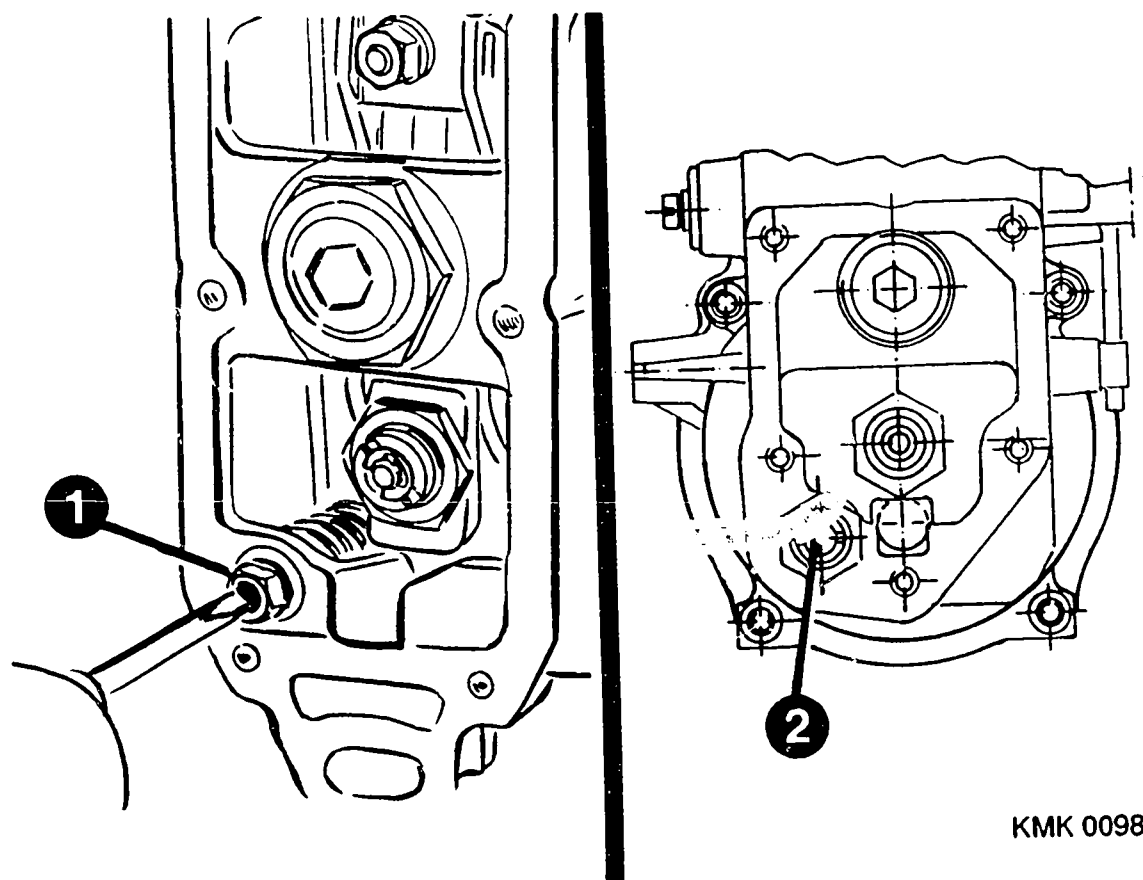

KMK 00983

- 1 = Adjusting screw for full-load control-rod travel
Pump with no active surge damping (ARD)
- 2 = Pump with ARD

DYNAMIC IDLE-STAGE ADJUSTMENT

* Setting applies to vehicle WITH no two-mass flywheel; pay attention to remarks on test-specification sheet.

With two-mass flywheel - as of Coordinate E09

Set full-load control-rod travel at speed "0" with control lever.

If control-rod travel is not attained, perform correction by way of adjusting screw for full-load control-rod travel.

Fix control lever.

Operate fuel-injection pump at $n = 1000 \text{ min}^{-1}$.
Loosen hexagon nut of spring retainer (torque-control retainer) using pin-type socket wrench KDEP 2968.

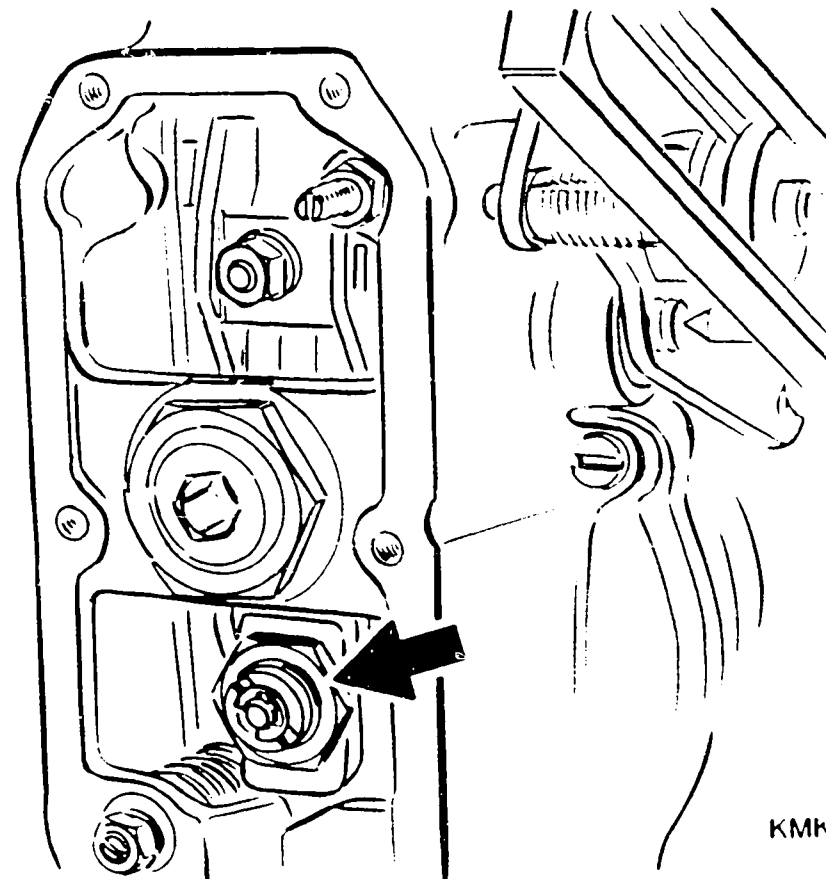

KMK 00940

Arrow = Spring retainer

Screw out spring retainer until control-rod travel as per test-specification sheet is obtained.
Tighten hexagon nut of spring retainer to 30...35 Nm.

Check control-rod travel again.

Continue as of Coordinate E11

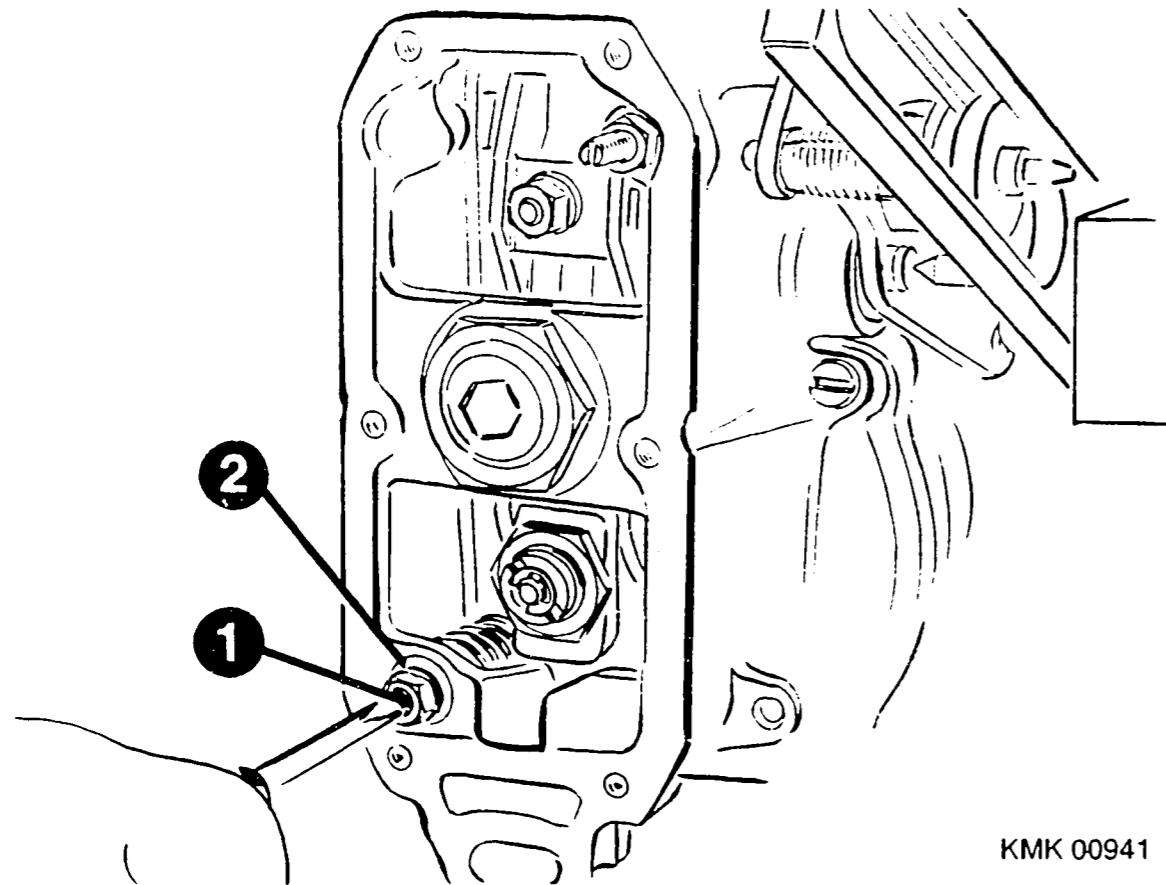

KMK 00941

1 = Adjusting screw for full-load control-rod travel

DYNAMIC IDLE-STAGE ADJUSTMENT

Setting applies only to vehicle with two-mass flywheels; pay attention to remark on test-specification sheet

At speed "0", press against guide lever such that flyweights are in inside position. Maintain pressure and use control lever to set 1st control-rod travel as per test-specification sheet in Section "TESTING LOWER RATED SPEED". If control-rod travel is not attained, perform correction by way of adjusting screw for full-load control-rod travel. Fix control lever.

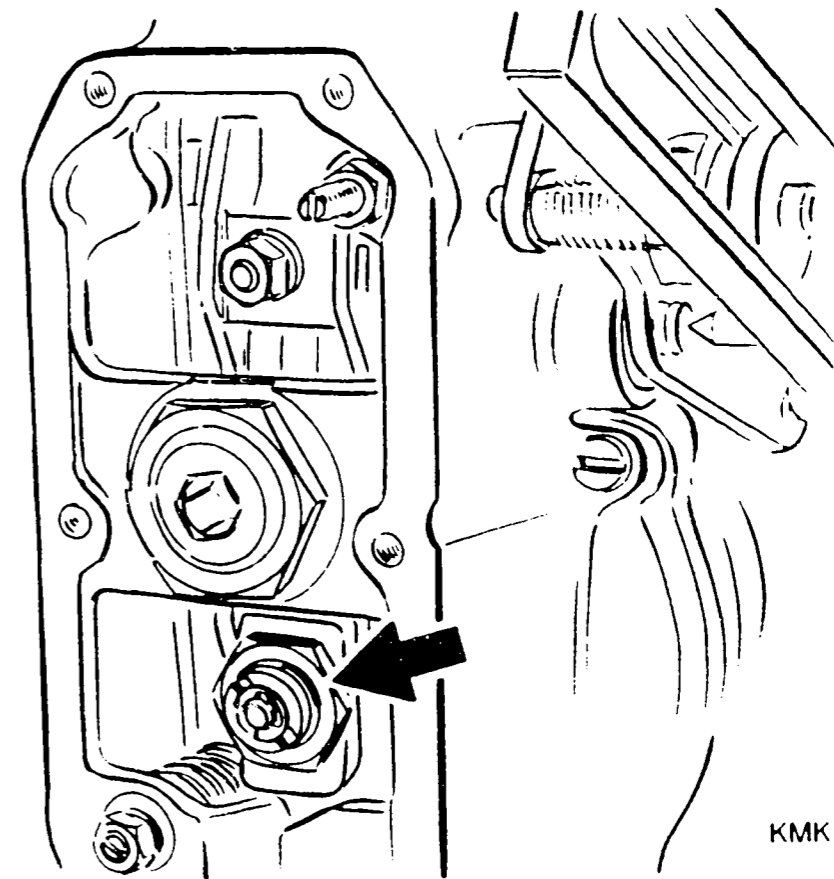

KMK 00940

Arrow = Spring retainer

Operate fuel-injection pump at $n = 1000 \text{ min}^{-1}$.

Use pin-type socket wrench KDEP 2968 to loosen hexagon nut of spring retainer (torque-control retainer). Screw out spring retainer until 4th control-rod travel as per test-specification sheet is attained. Tighten hexagon nut of spring retainer to 30...35 Nm.

Start up fuel-injection pump with 1st speed indicated under "Testing" and check set control-rod travel. Perform correction at full-load adjusting screw.

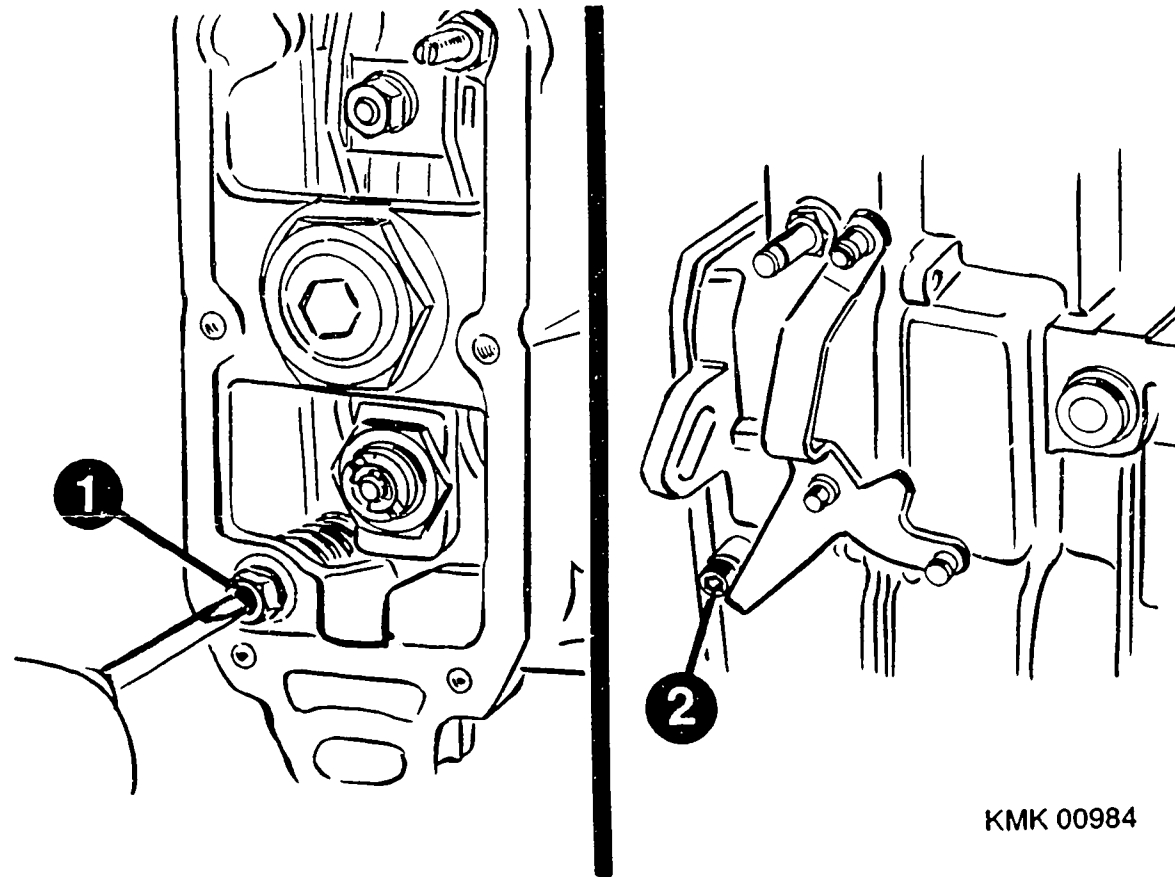

KMK 00984

1 = Adjusting screw for full-load control-rod travel
 2 = Full-load stop

ADJUSTING FULL-LOAD CONTROL-ROD TRAVEL AND MEASURING DELIVERY.

* Section "Full-load delivery at full-load stop and torque control, 1st speed indication"

Loosen control lever and position against full-load stop (head of hexagon-socket-head cap screw on governor-control-lever side)

Operate fuel-injection pump at corresponding speed.
 Set control-rod travel by way of adjusting screw for full-load control-rod travel.
 Tighten hexagon nut to 5...7 Nm.
 Check delivery.

If delivery is not attained, correct control-rod travel within tolerance.

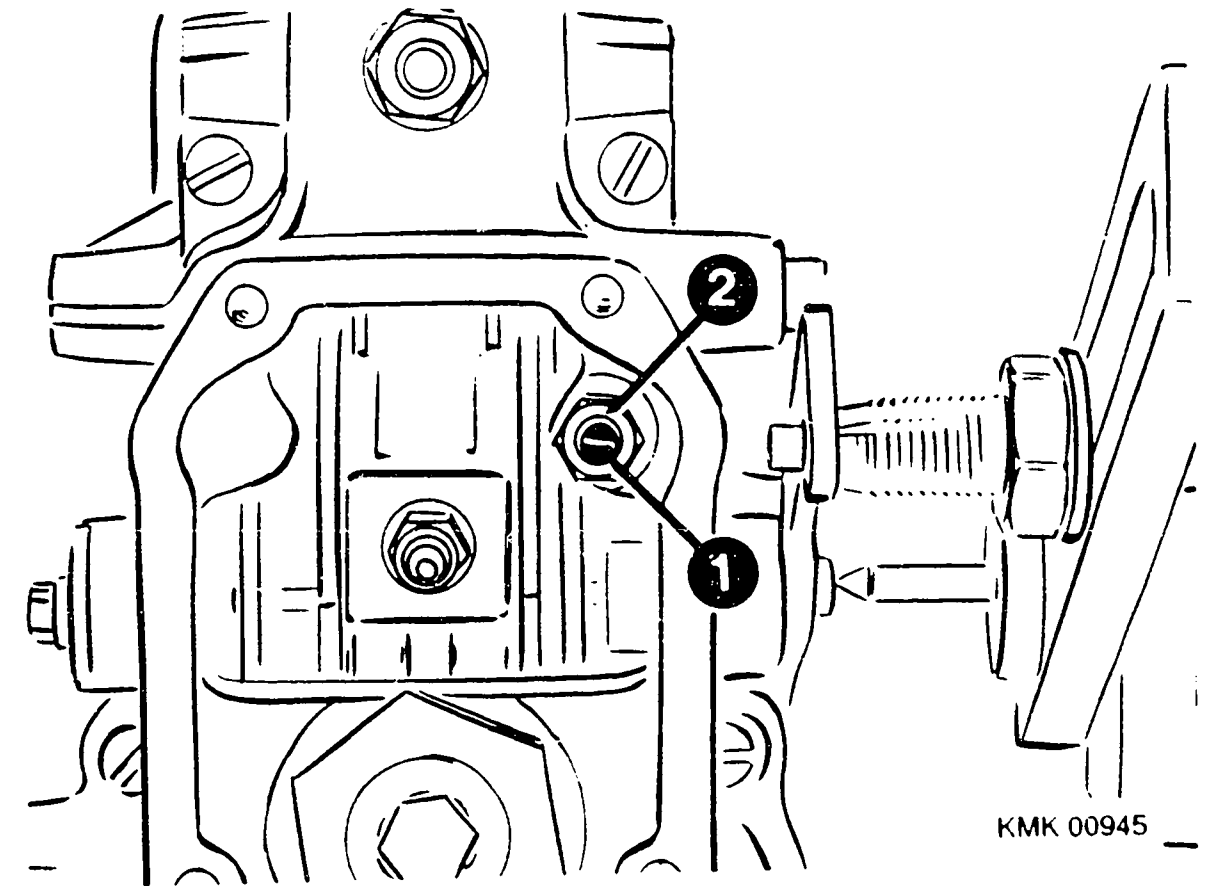

KMK 00945

1 = Idle stop screw

ADJUSTING POSITION OF IDLE CONTROL LEVER

Operate fuel-injection pump at stated speed.
 Loosen control lever of governor.
 Screw in idle stop screw after loosening hexagon nut such that control-rod travel as per test-specification sheet is obtained.

The resultant control-lever deflection must be within the prescribed control-lever tolerance as indicated in Section "LOWER RATED SPEED".

If prescribed control-lever position is not attained, correct set control-rod travel within permitted control-rod-travel tolerance.

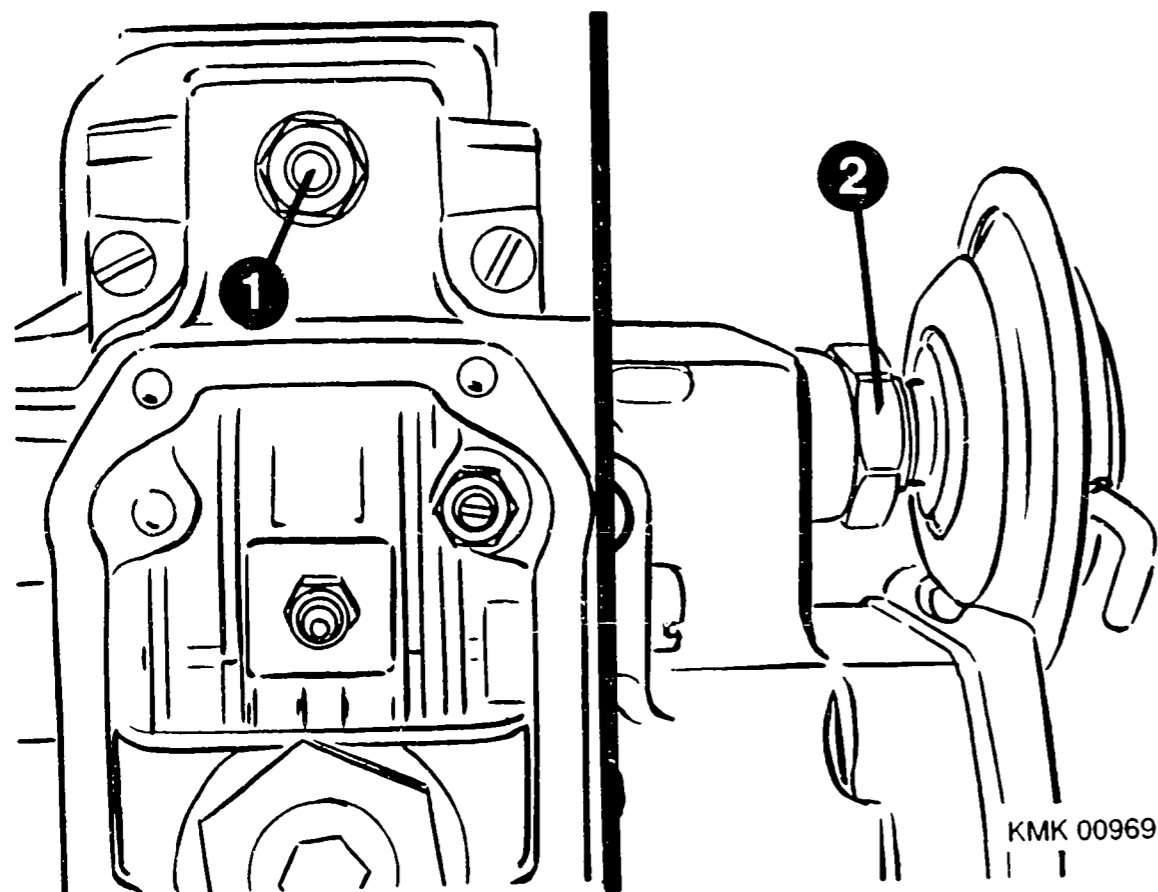

1 = Idle adjusting screw
2 = Pneumatic idle increase

ADJUSTING IDLE CONTROL-ROD TRAVEL AND MEASURING DELIVERY
* Section "LOWER RATED SPEED"

Position control lever against idle stop.
Operate fuel-injection pump at prescribed speed.
Loosen hexagon nut of idle adjusting screw or PLA unit.
Screw in PLA unit or idle adjusting screw until stated control-rod travel is attained.

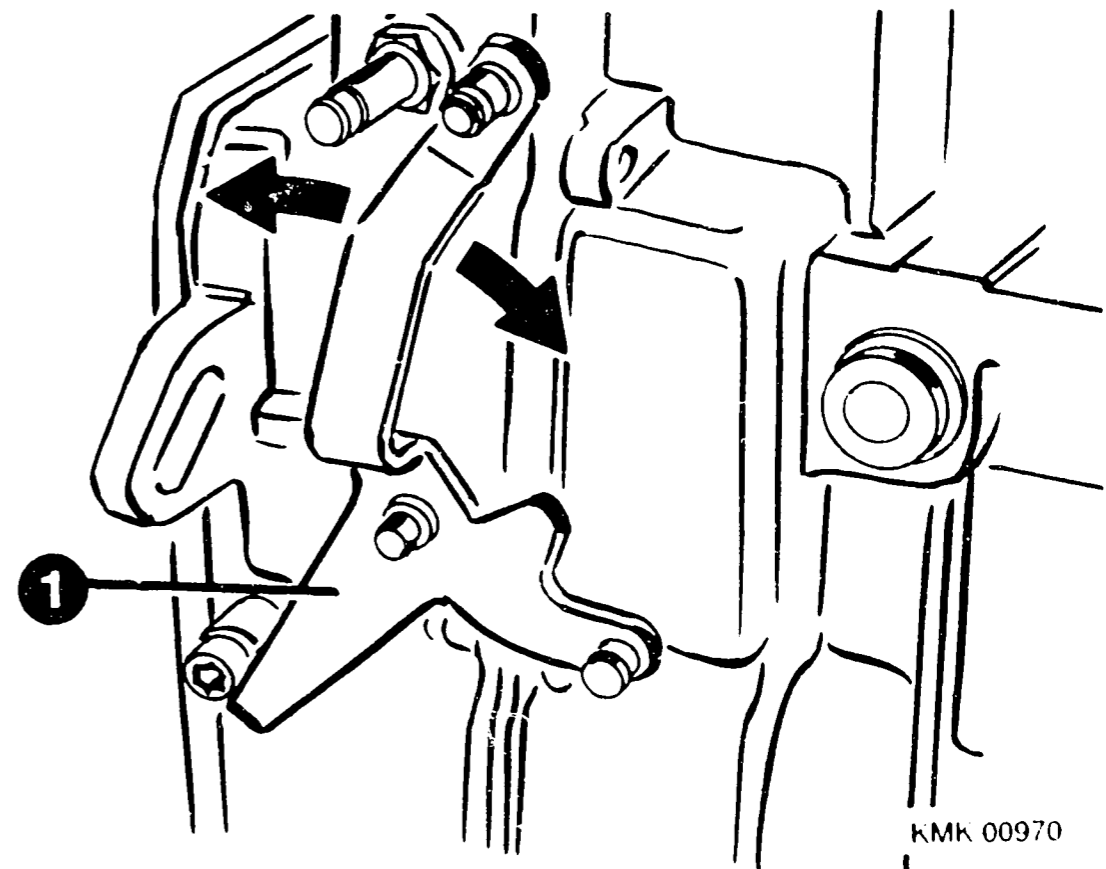

1 = Control lever

Loosen control lever and move it back and forth.
Fix control lever in idle position.

Set control-rod travel must be obtained again.
Repeat adjustment in the event of deviations.

Operate fuel-injection pump at idle speed and measure delivery.
Correct idle control-rod travel within permitted tolerance in the event of deviations.

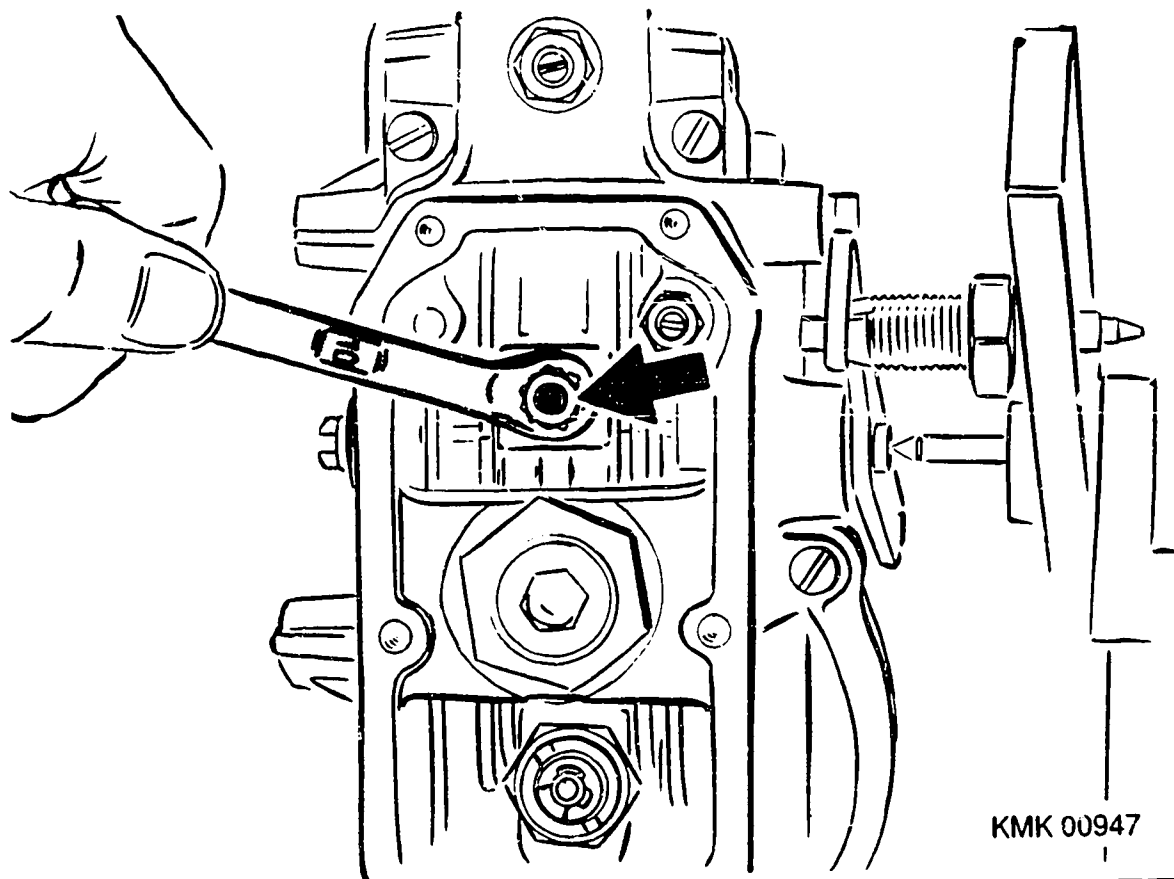

Arrow = Lock nut

ADJUSTING IDLE AUXILIARY SPRING

Operate fuel-injection pump.
Position control lever against idle stop.

Screw lock nut in direction of governor housing until prescribed control-rod travel is attained.

Loosen control lever whilst maintaining set speed and move it back and forth once.

Fix control lever again in idle position.

Set control-rod travel must be re-attained.

CHECKING POPPET CONTROL-ROD-TRAVEL PROFILE POINT

* Section "Lower rated speed"

3rd speed indication

Operate fuel-injection pump. Control-rod travel must be attained within speed tolerance.

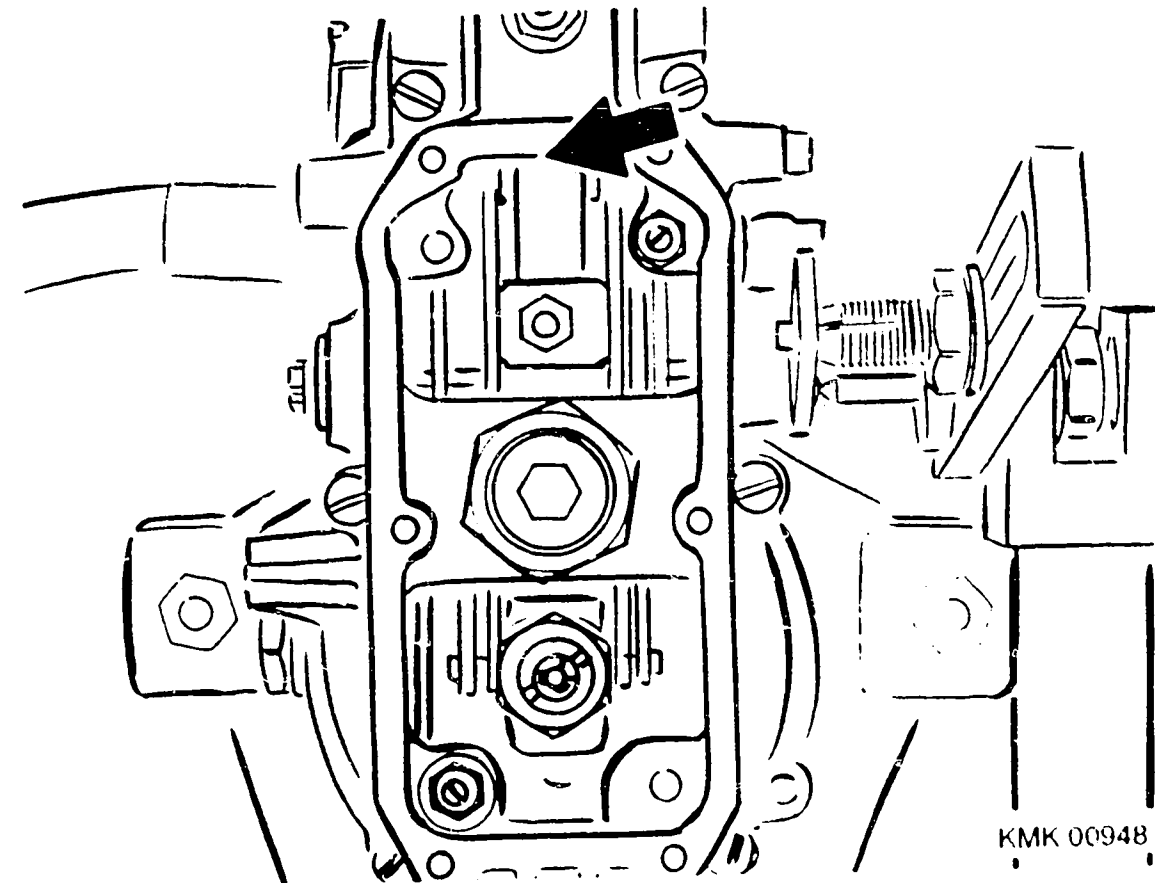

Arrow = Leaf spring

CHECKING LOAD TAKE-UP

* Section "Lower rated speed"

Testing: 1st speed indication

Use speed as per test-specification sheet.

Check control-rod travel on dial indicator.

Check freedom of movement of governor linkage in the event of deviations from set value.

Renew leaf spring if necessary.

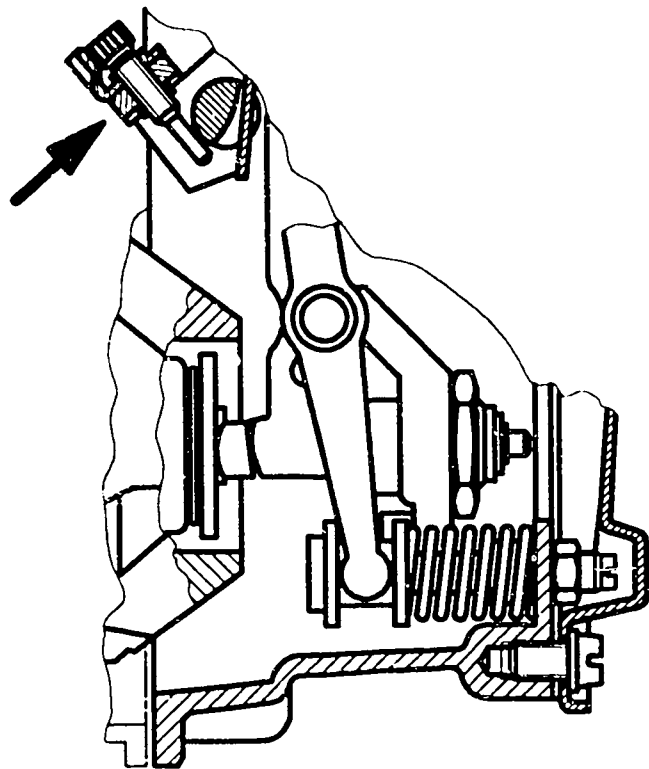

KMK00985

Arrow = Poppet shutoff screw

IDLE AUXILIARY SPRING SHUTOFF
(Checking poppet shutoff)

* Section "Remarks"

Note:

Refer to test-specification sheet for differing data

Fix control lever at 50°.
Approach speed and establish control-rod travel.

Set control lever to 40°.
Approach speed.
Permitted control-rod-travel deviation 0...0.3 mm

Control-rod-travel deviation outside tolerance:

Turn poppet adjusting screw.
Control-rod travel excessive:
Screw out poppet screw.

Procedure:

Remove pneumatic shutoff unit and turn poppet shutoff screw with ball-type Torx wrench by way of opening in pump housing.

Check poppet shutoff again

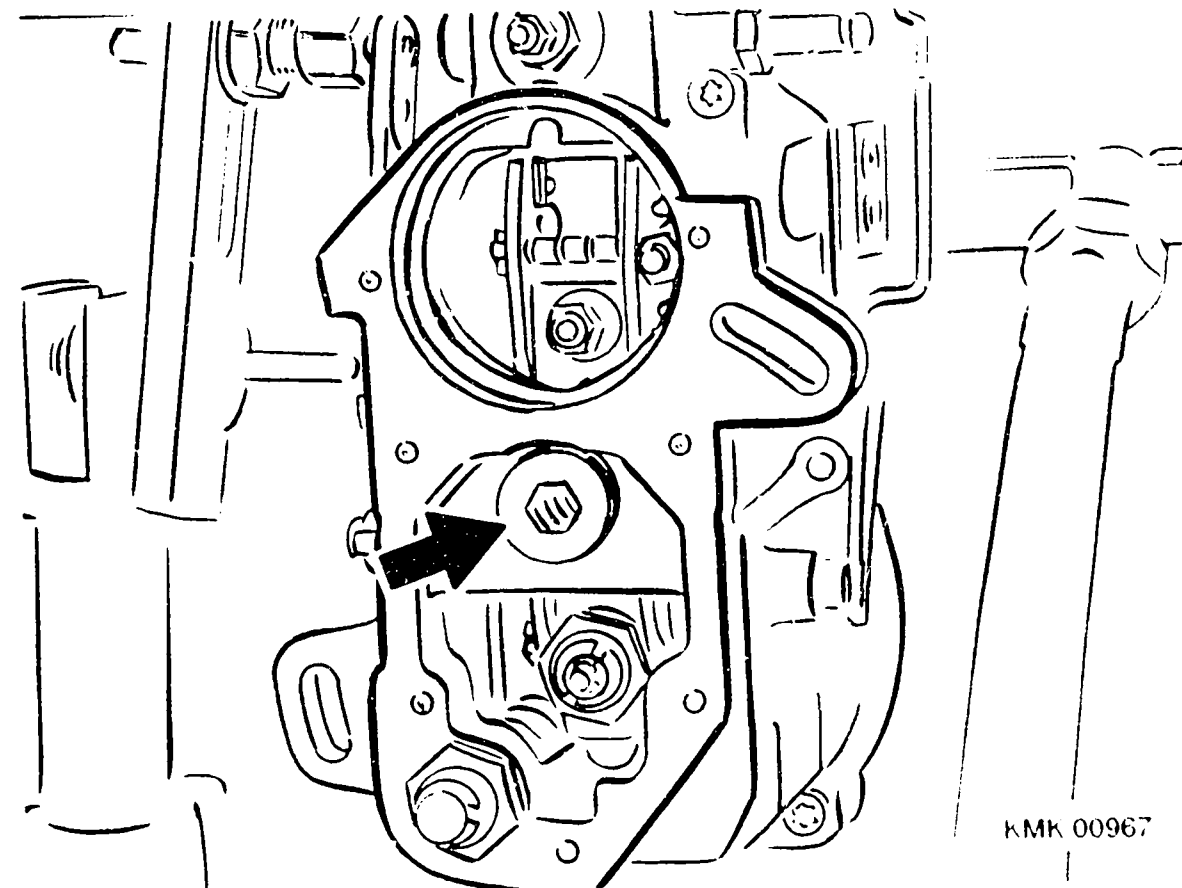

KMK 00967

Arrow = Threaded sleeve

ADJUSTING FULL-LOAD SPEED REGULATION

* Test section "UPPER RATED SPEED"

Operate fuel-injection pump at 1st speed as indicated in test-specification sheet.

Screw out threaded sleeve until stated control-rod travel is obtained.

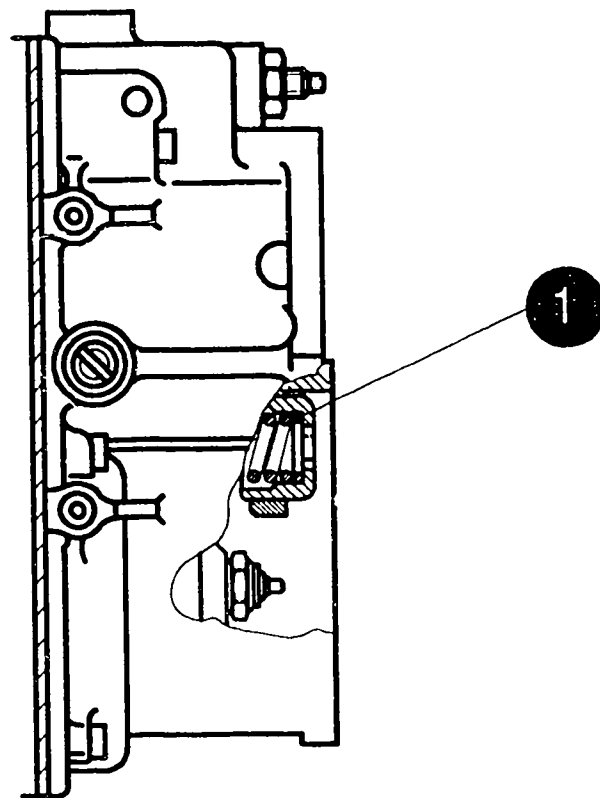

KMK00986

1 = Threaded sleeve

CHECKING HIGH IDLE

Operate fuel-injection pump at stated speed and measure delivery.
 Delivery as per test-specification sheet must be attained.

Effect correction at threaded sleeve.
 To do so, loosen hexagon nut.

The control-rod-travel tolerance (SECTION "UPPER RATED SPEED, 1ST SPEED INDICATION") must always be complied with.

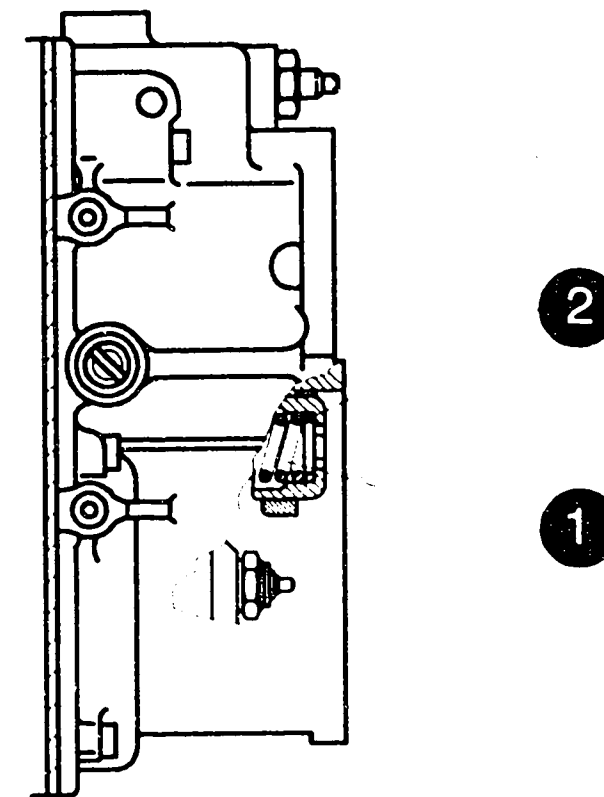

KMK00968

1 = Governor spring
 2 = Shims

If the required delivery is not attained without exceeding the control-rod-travel tolerance, check freedom of movement of governor; replace governor spring.

Note:
 Teflon-coated side of plain washer should be installed facing retainer.
 Repeat governor adjustment after replacing governor spring.

Governor adjustment as of Coordinate E06

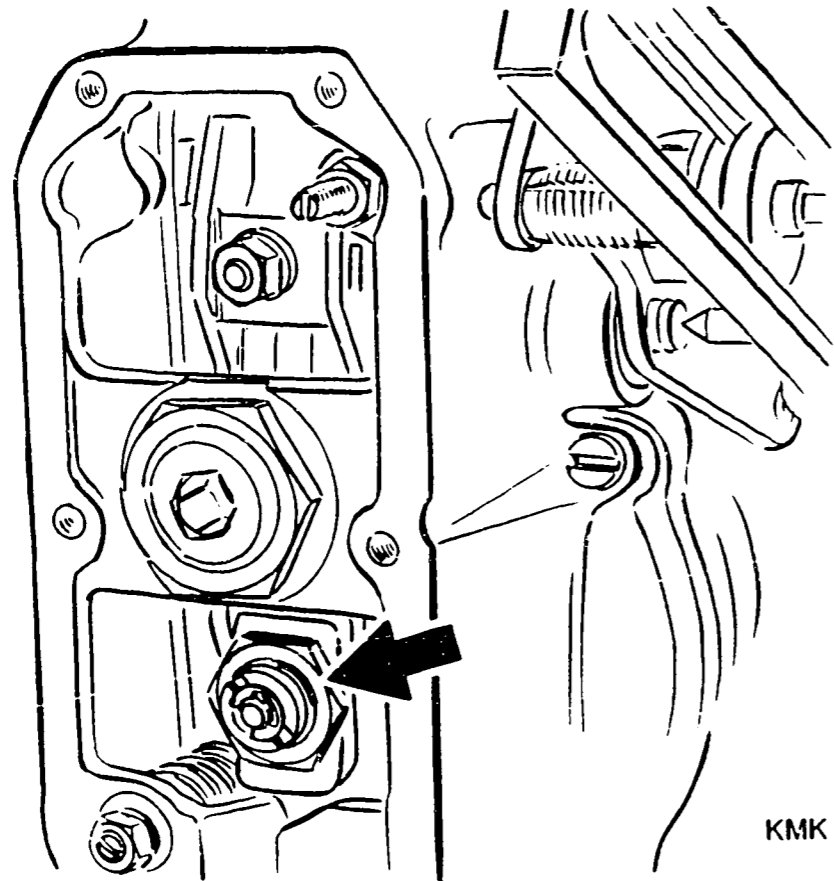

KMK 00940

Arrow = Torque-control retainer

CHECKING POSITION OF SLIDING SLEEVE

* Test section, upper rated speed 2nd speed indication

Operate fuel-injection pump in accordance with test-specification sheet.

Control-rod travel as per test-specification sheet must be reached.

Correct slight deviations (± 0.3 mm by adjusting torque-control retainer.

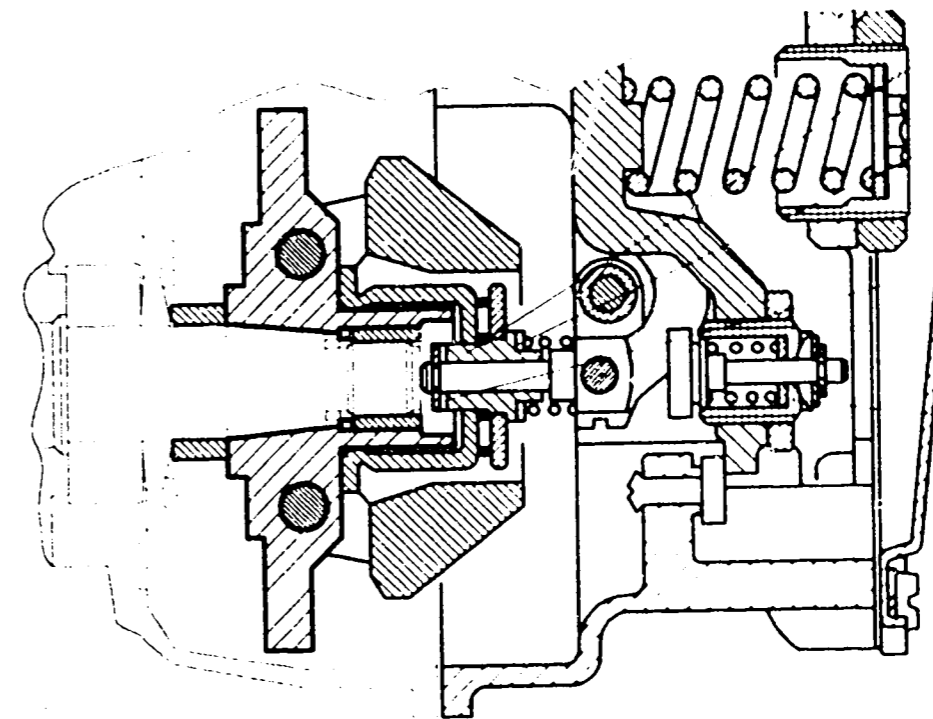

KMK00977

2 = Spring retainer (negative torque control)

CHECKING TORQUE-CONTROL PROFILE

* Section "Torque control and fuel-delivery characteristics"

Check negative torque control:

Position control lever against full-load stop.

Approach 4th speed as per test-specification sheet.

Measure control-rod travel and delivery.

If control-rod travel and delivery are not attained, replace spring retainer of negative torque control in line with service-parts list.

Remove and disassemble governor.

Remove spring retainer.

Repeat governor adjustment as of Coordinate E06.

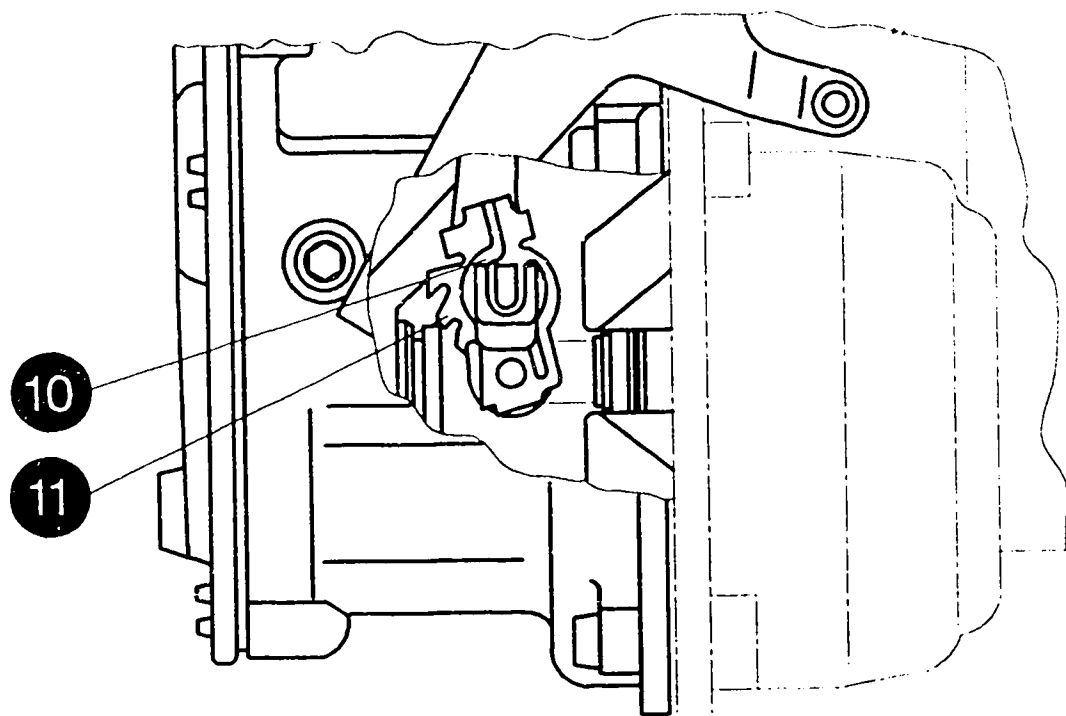

KMK00979

10 = Spiral spring
11 = Catch disc

Approach 5th speed as per test-specification sheet.
Measure control-rod travel and delivery.

If control-rod travel and delivery are not attained,
alter position of spiral spring within catch disc.

Control-rod travel and delivery too large -
* position spiral spring downwards.
Control-rod travel and delivery too small -
* position spiral spring upwards.

Note:
Spiral spring must be reliably engaged.
Check control-rod travels again.

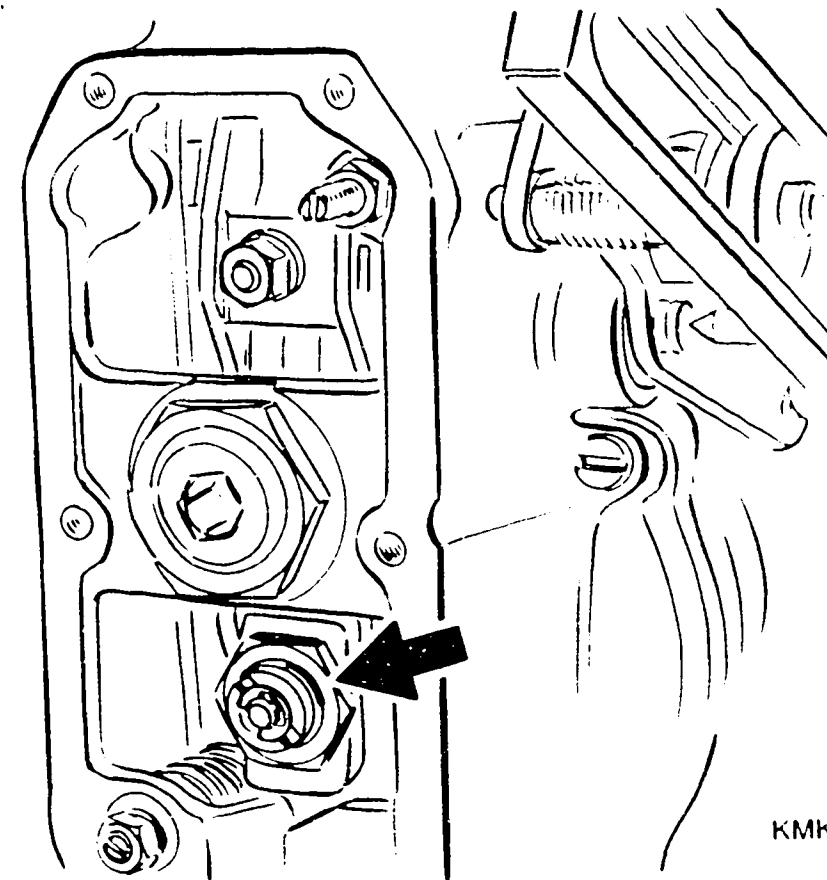

KMK 00940

Arrow = Spring retainer

Checking positive torque control:

Operate fuel-injection pump at corresponding speeds 1...3.
Check control-rod travels on dial indicator.
At same speed, check delivery in accordance with Section
"Fuel-delivery characteristics".

Renew spring retainer in the event of deviations.
After replacing spring retainer, repeat governor
adjustment as of Coordinate E06.

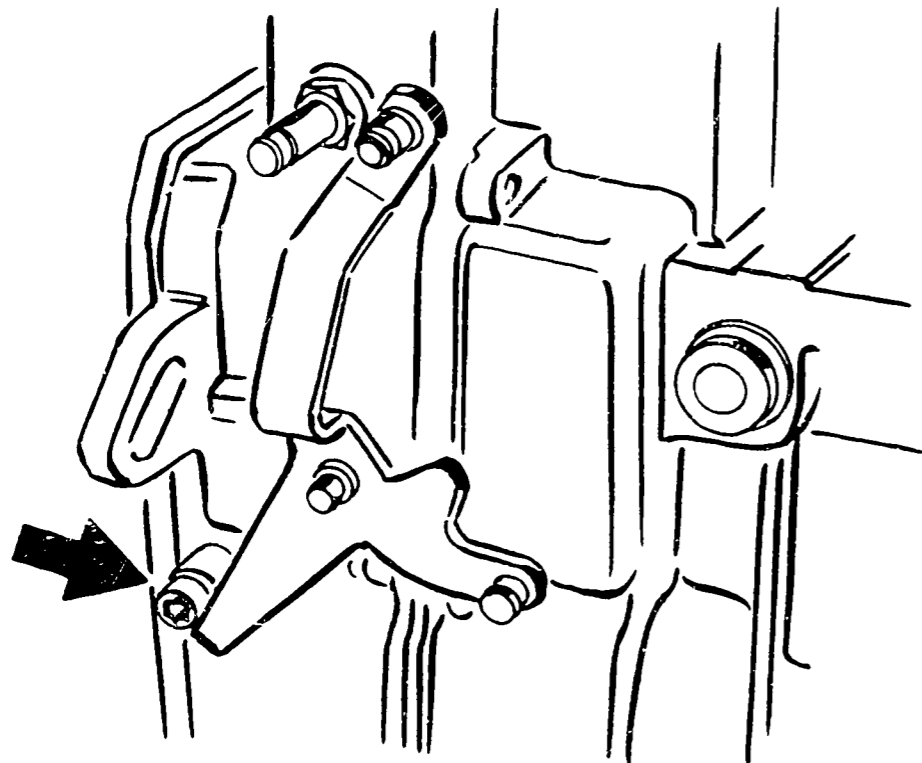

KMK 00965

Arrow = Full-load stop

MEASURING STARTING CONTROL-ROD TRAVEL AND DELIVERY

Position control lever of governor against full-load stop (head of hexagon-socket-head cap screw on governor-control-lever side) and fix.

Operate fuel-injection pump and check control-rod travel on dial gauge.
Measure delivery at same speed.

Check adjustment of full-load control-rod travel in the event of deviations.
Check control rod for freedom of movement (e.g. catching of control rod in oblique position).

- * Continue as of Coordinate E26 if there are no add-on modules
- * Continue as of Coordinate E28 if there are add-on modules

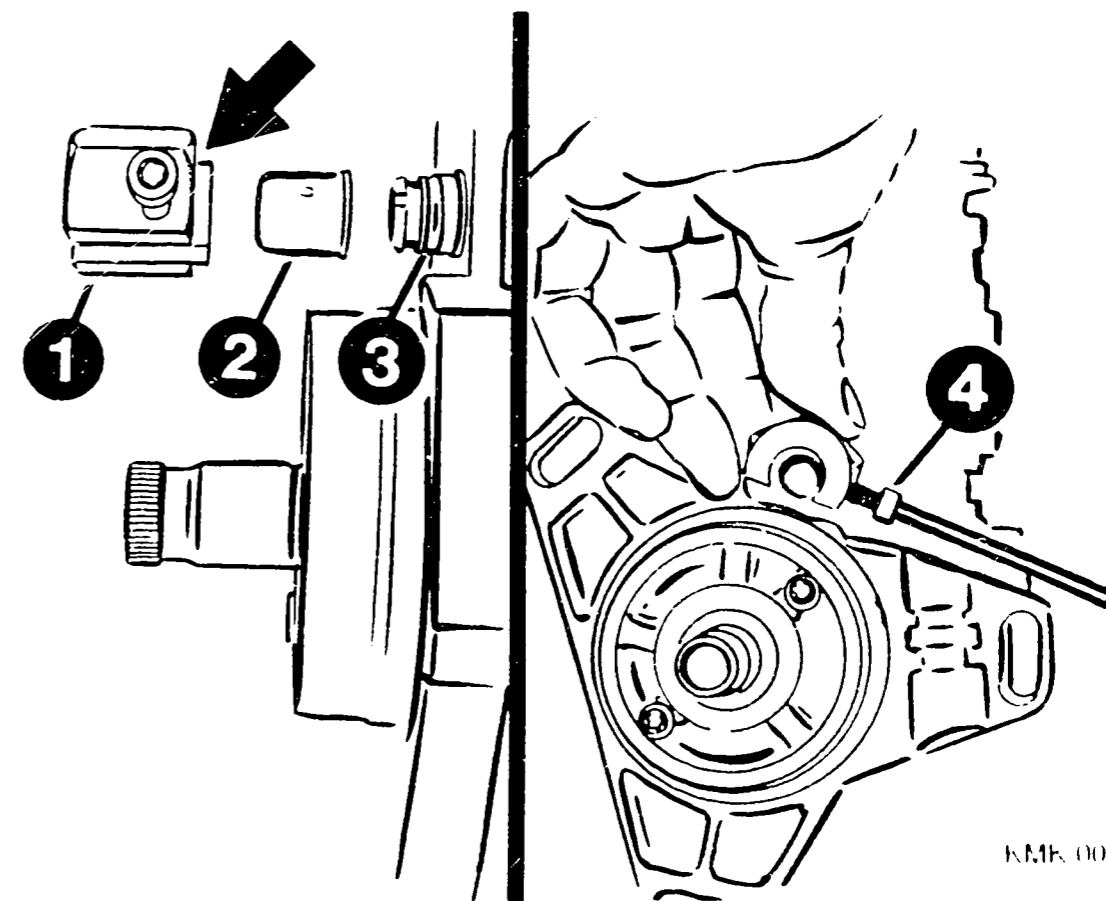

KMK 00970

- 1 = Embossing tool
- 2 = Control-rod closing cap
- 3 = Control-rod guide sleeve
- 4 = Hexagon-socket-head cap screw

Remove control-rod-travel measuring device.
Slip new control-rod closing cap onto control-rod guide sleeve as far as it will go.

Slip embossing tool KDEP 1635 over guide sleeve such that machined collar (arrow) makes contact with pump housing.

Screw in hexagon-socket-head cap screw until increased resistance is felt.

CONCLUDING WORK

Check function of shutoff unit with appropriate vacuum.

Completely assemble fuel-injection pump.

Perform leak test on camshaft chamber with test cone KDEP 1565.

Connect up compressed-air hose to test cone.

Check injection-pump assembly for leaks in oil bath at 0.5 bar gauge.

Attach lead seal to fuel-injection pump and governor.

ATTACHING AND TESTING ADD-ON MODULES

Add-on modules	Coordinates
----------------	-------------

Tools and test equipment for adjustment purposes	F01
--------------------------------------------------------	-----

Ambient-pressure-dependent full-load stop (ADA)	F03
-------------------------------------------------------	-----

Absolute boost pressure-dependent full-load stop (ALDA).....	F09
--------------------------------------------------------------	-----

Rack position sensor	F16
----------------------------	-----

TOOLS AND TEST EQUIPMENT

Tools Test equipment	Type des'g./ part no.	Application
Tuning device	KDEP 1070	Measuring pin projection
Vacuum gauge with adjuster Measuring range 0 - 280 hPa	1 688 130 032	Vacuum testing
Adjuster	1 688 130 132	Pressure regulation
Test line	KDEP-P400/4	Checking/ adjusting rack position sensor
Regulator 12V 0.5/3A	commercially available	Voltage supply
Voltmeter (digital multimeter; measuring range: 0...5 ±1 V Accuracy: ±0.02 % of reading (value))	commercially available	Checking/ adjusting rack position sensor
ALDA tester	0 684 200 610	Pressure/ vacuum supply

TOOLS AND TEST EQUIPMENT

Tools Test equipment	Type desig./ part no.	Application
Evaluation circuit (test control unit)	R5-1.2	Checking/ adjusting rack position sensor
System adapter lead	KDEP-P400/4	Checking/ adjusting rack position sensor/M/RSFII
Puller	KDEP 1573	Removing ELR servo magnet

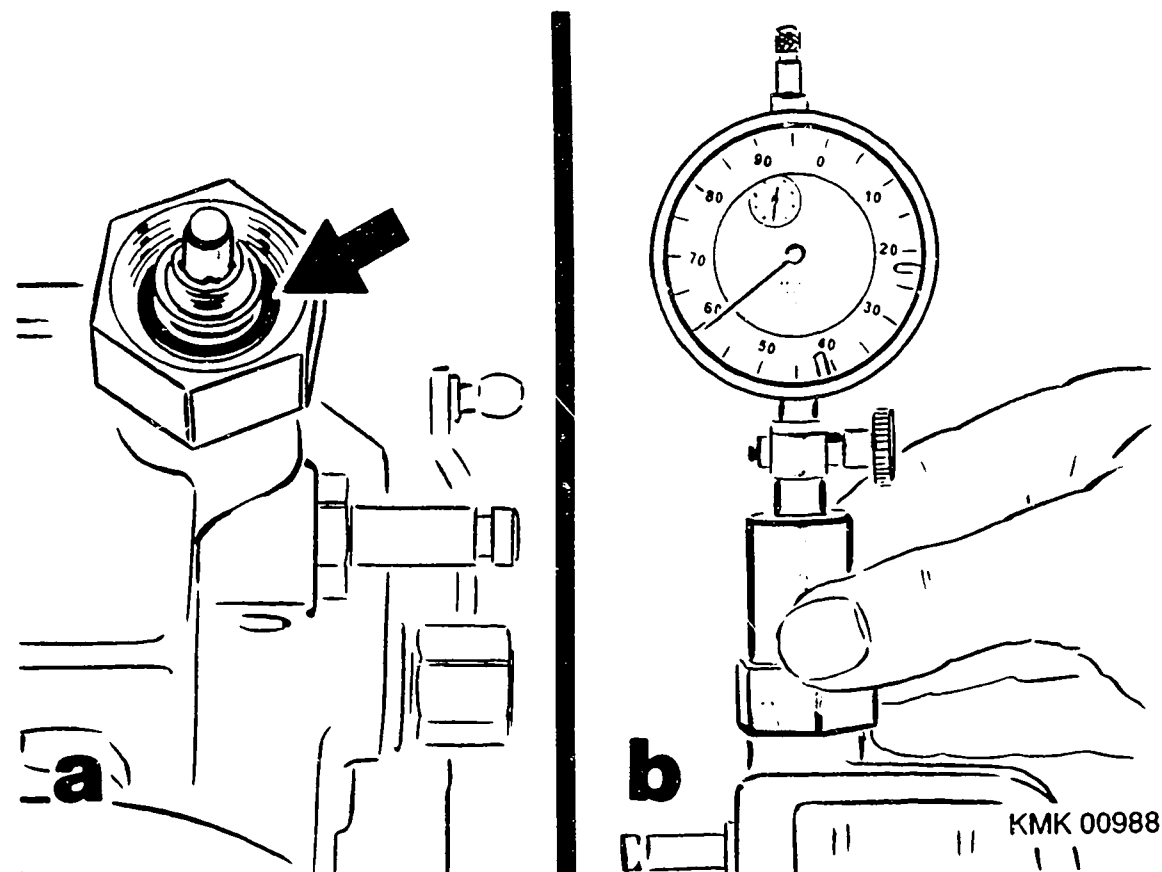

ADJUSTING AMBIENT-PRESSURE-DEPENDENT FULL-LOAD STOP ADA

Checking pin projection:
Do not as yet fit ADA aneroid box.

Lay tuning device KDEP 1070 with measurement sleeve flat on marking plate (clamping rail of test bench).
Pre-tension dial indicator approx. 1-2 mm and set to "0".

Place tuning device with measurement sleeve on shim(s) (arrow).
Take pin projection from test-specification sheet.

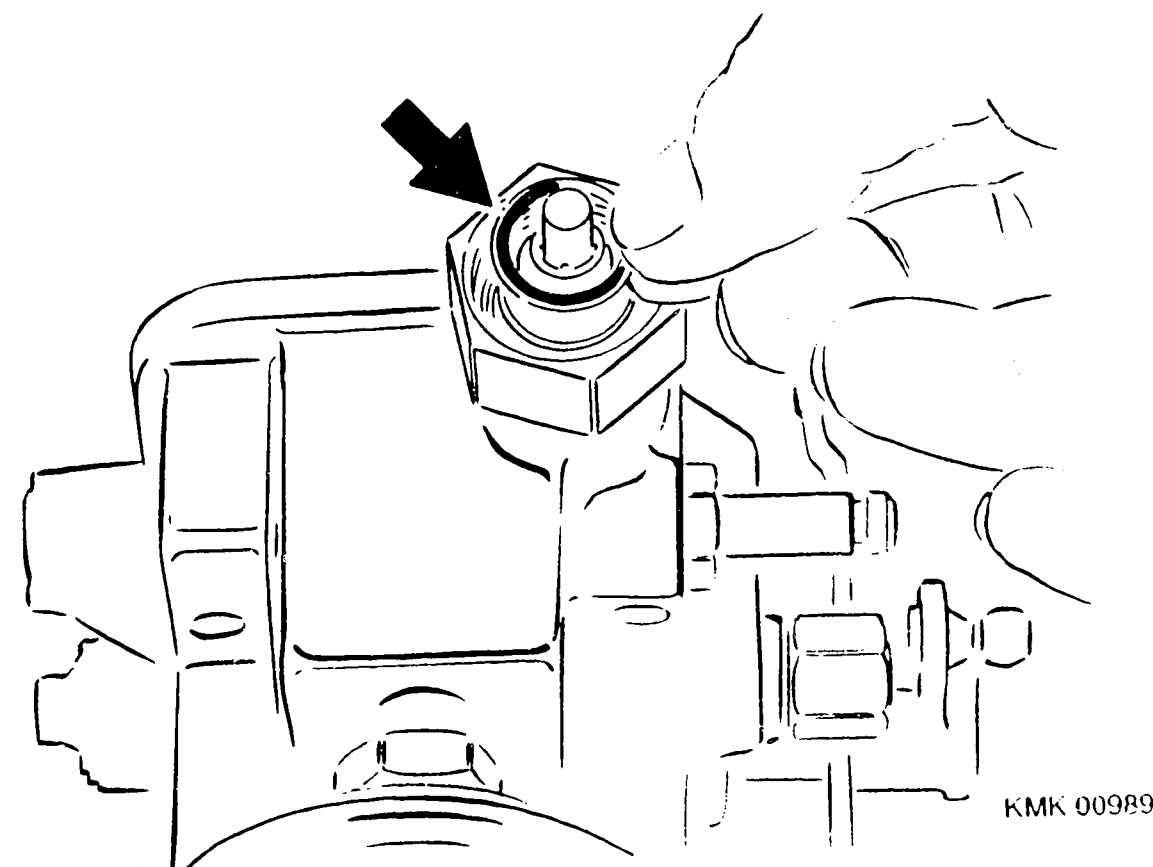

Arrow = Shim

* Adjust pin projection.

If pin projection differs from stated value, projection must be adjusted by replacing shim(s).

Note:
If dial indicator shows larger dimension, thicker shims are to be fitted and vice versa.

Fit ADA aneroid box with measured shims.

Tighten cap nut to 50...70 Nm.

* Depending on atmospheric pressure, the following tests are performed either with gauge pressure or vacuum.

Vacuum is to be used for test purposes if the atmospheric pressure (barometer reading) is higher than the absolute pressure indicated on the test-specification sheet. Otherwise, gauge pressure is to be used.

DETERMINING GAUGE PRESSURE OR VACUUM

Example of vacuum calculation:

Atmospheric pressure	1000 hPa
Setting (absolute pressure) as per test-specification sheet	840 hPa

Required vacuum Setting	160 hPa
----------------------------	---------

Example of gauge-pressure calculation:

Setting (absolute pressure)	1100 hPa
Atmospheric pressure	950 hPa

Required gauge pressure	150 hPa
-------------------------	---------

TEST CONNECTIONS

ALDA TESTER:

Press ADA button if testing is performed with ALDA tester. The displayed pressure is then the absolute pressure.

Press LDA button if testing has to be performed with gauge pressure.

Connect up ADA connection to ALDA tester.

VACUUM UNIT:

If testing is performed with vacuum unit, connect up vacuum unit to lower connection of tester.

Connect upper connection of adjuster to breather pipe of aneroid box.

If gauge pressure is required for testing, remove vacuum gauge and install pressure gauge 0 - 1.6 hPa at adjuster.

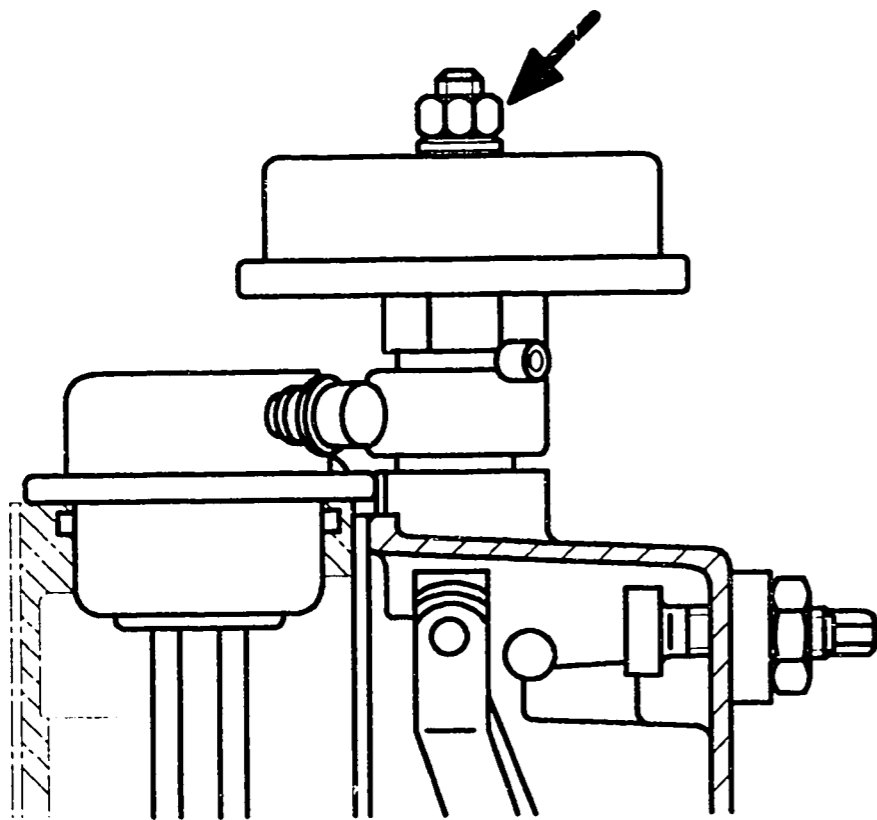

KMK00990

Arrow = Adjusting screw

SETTING ADA ADJUSTMENT

* Section "Adjustment"

Operate fuel-injection pump at appropriate speed.
Position control lever against full-load stop.

Apply calculated gauge pressure/vacuum to aneroid box.

The resultant decrease in control-rod travel from the max. full-load control-rod travel must correspond to the figure given on the test-specification sheet.

Perform correction (if provided) at adjusting screw.
Renew ADA aneroid box.

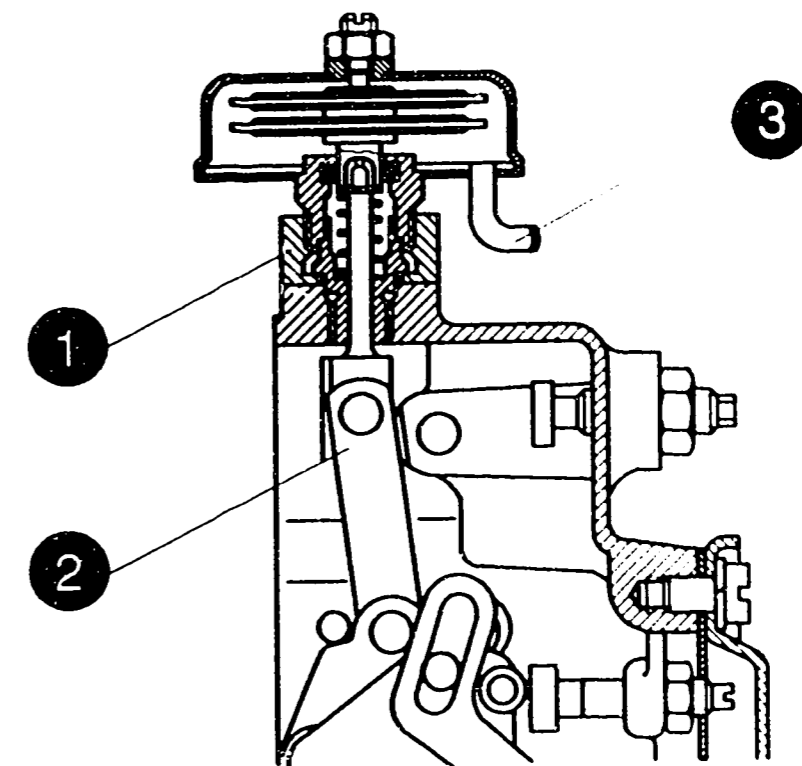

KMK00991

1 = Cap nut

2 = Correction linkage

3 = Connecting line into open air for determining atmospheric pressure

CHECKING ADA ADJUSTMENT

* Section "Measurement"

Determine required gauge pressure/vacuum.
If decrease in control-rod travel is not within stated tolerance, replace ADA aneroid box.

Repeat measurement.

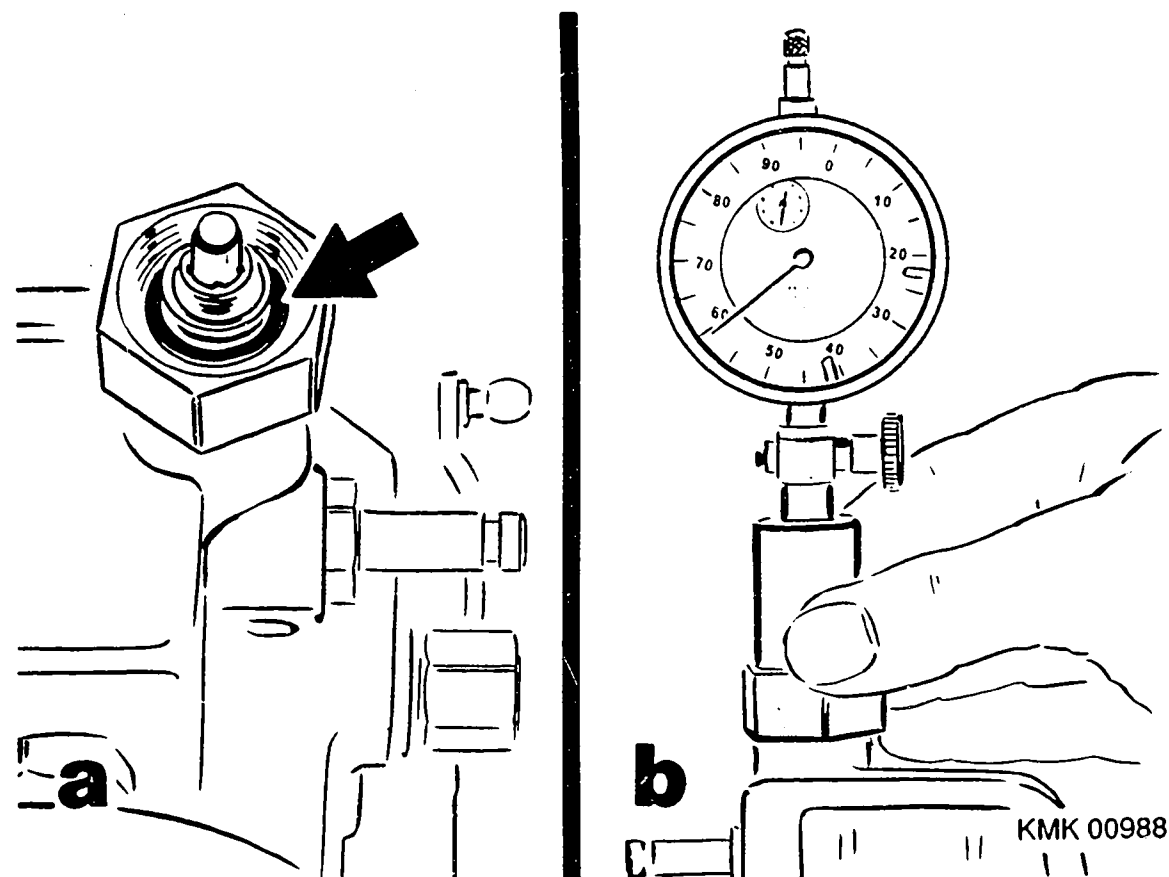

ADJUSTING ABSOLUTE BOOST PRESSURE-DEPENDENT FULL-LOAD STOP (ALDA)

Checking pin projection:
Do not as yet fit ALDA aneroid box.

Lay tuning device KDEP 1070 with measurement sleeve flat on marking plate (clamping rail of test bench).
Pre-tension dial indicator approx. 1-2 mm and set to "zero".

Place tuning device with measurement sleeve on shim(s) (arrow).
Take pin projection from test-specification sheet.

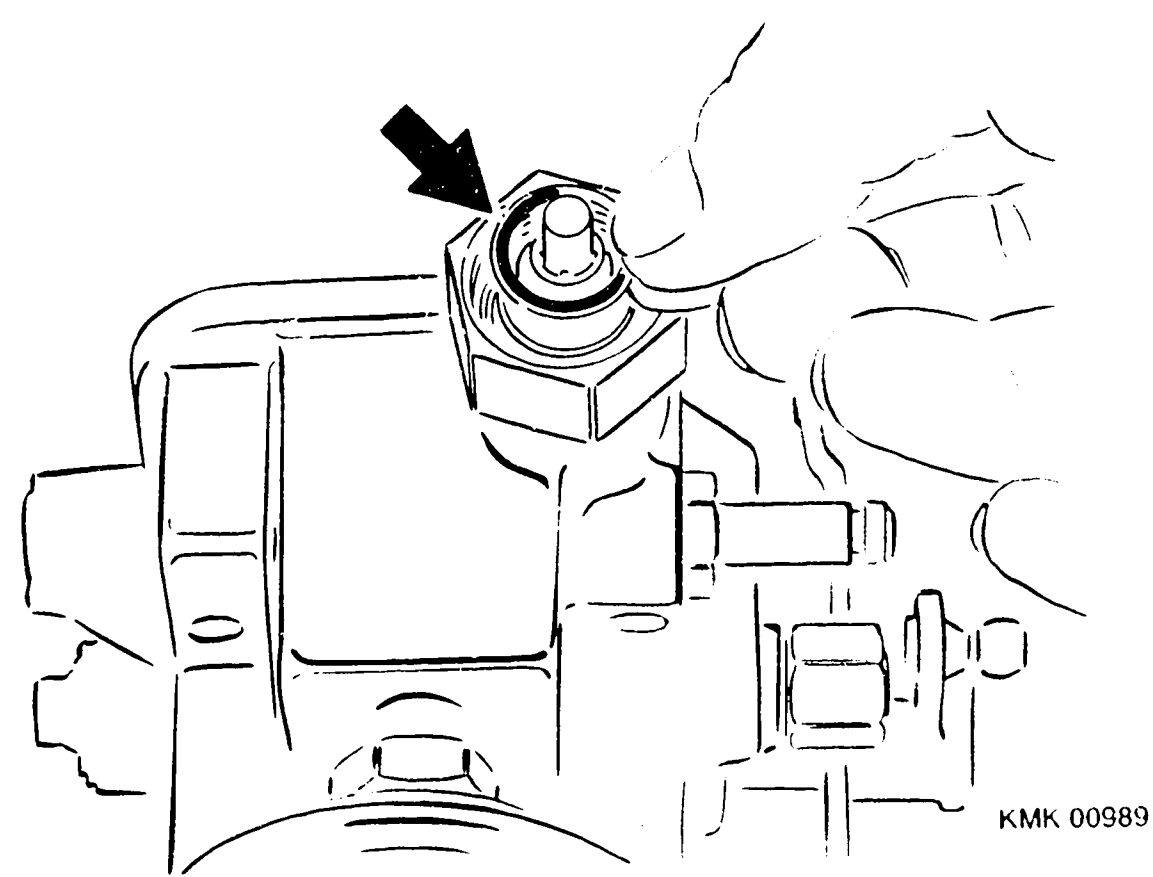

Arrow = Shim

* Adjust pin projection.

If pin projection deviates from stated value, projection must be adjusted by replacing shim(s).

Note:
If dial indicator shows larger dimension, use is to be made of thicker shims and vice versa.

Fit ALDA aneroid box with measured shims.

Tighten cap nut to 50...70 Nm.

For testing with ALDA aneroid box, it is necessary to calculate respective differential pressure with respect to instantaneous atmospheric pressure (barometer reading).

Establish atmospheric pressure.

Calculate differential pressure:

Example:

Absolute pressure as per test-specification sheet	1050 hPa
Determined atmospheric pressure	980 hPa

Differential pressure	070 hPa
-----------------------	---------

Calculate maximum pressure:

Example:

Maximum absolute pressure as per test-specification sheet	1850 hPa
Determined atmospheric pressure	980 hPa

Maximum pressure	870 hPa
------------------	---------

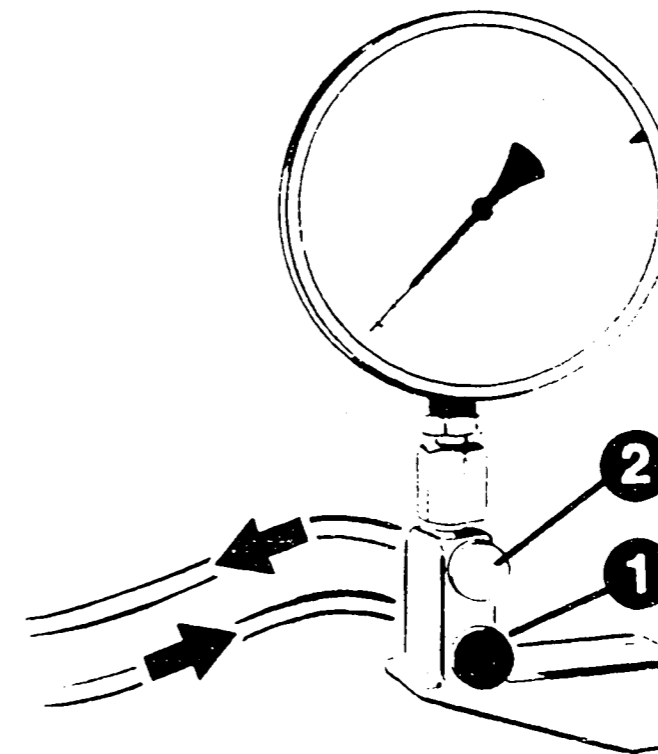

EMK 01105

1 = Screw for adjusting various pressures
2 = Screw plug, ALDA connection

LAYING OF LINES TO ALDA UNIT

* with compressed-air connection

Set maximum pressure at pressure regulator.
Connect up lower connection of adjuster to pressure regulator.
Connect up ALDA to upper connection of adjuster.
Apply calculated differential pressure to ALDA aneroid box.

*with ALDA tester

Connect up ALDA connection to tester.
Press ALDA button on tester.
Set absolute pressure in accordance with test-specification sheet.

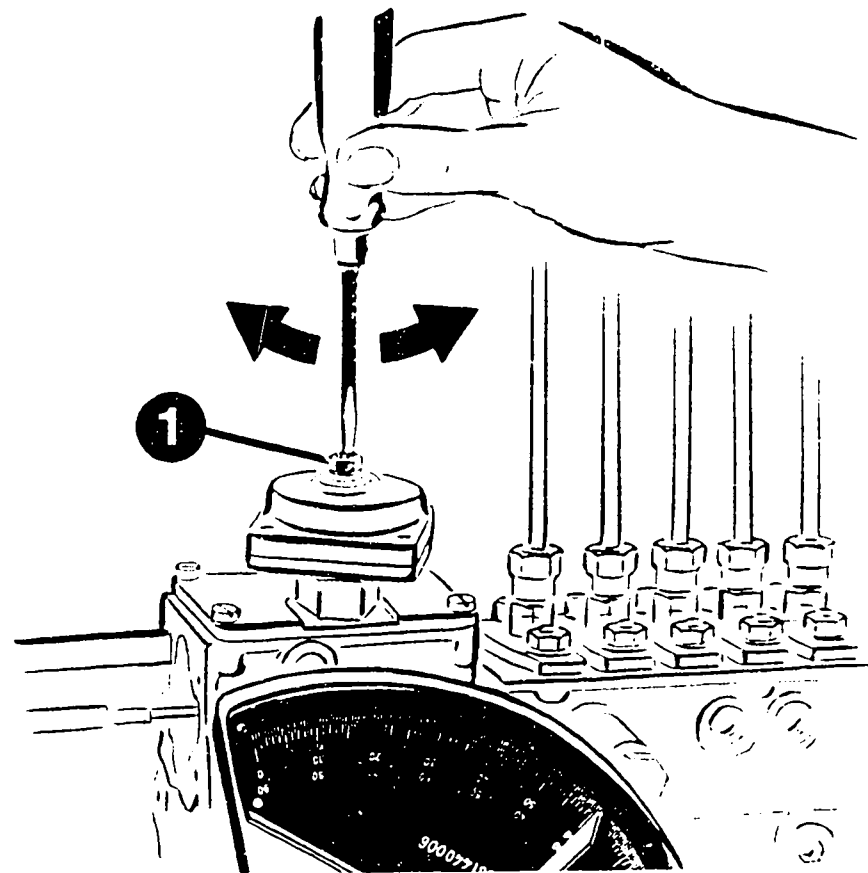

KMK 01106

1 = Adjusting screw

SETTING ALDA ADJUSTMENT
* Section "Adjustment"

Operate fuel-injection pump at appropriate speed.
Position control lever against full-load stop.

Apply calculated differential pressure or absolute pressure to aneroid box.

The resultant reduction in control-rod travel from the max. full-load control-rod travel must correspond to the value given on the test-specification sheet.

Perform correction at adjusting screw, ALDA aneroid box.

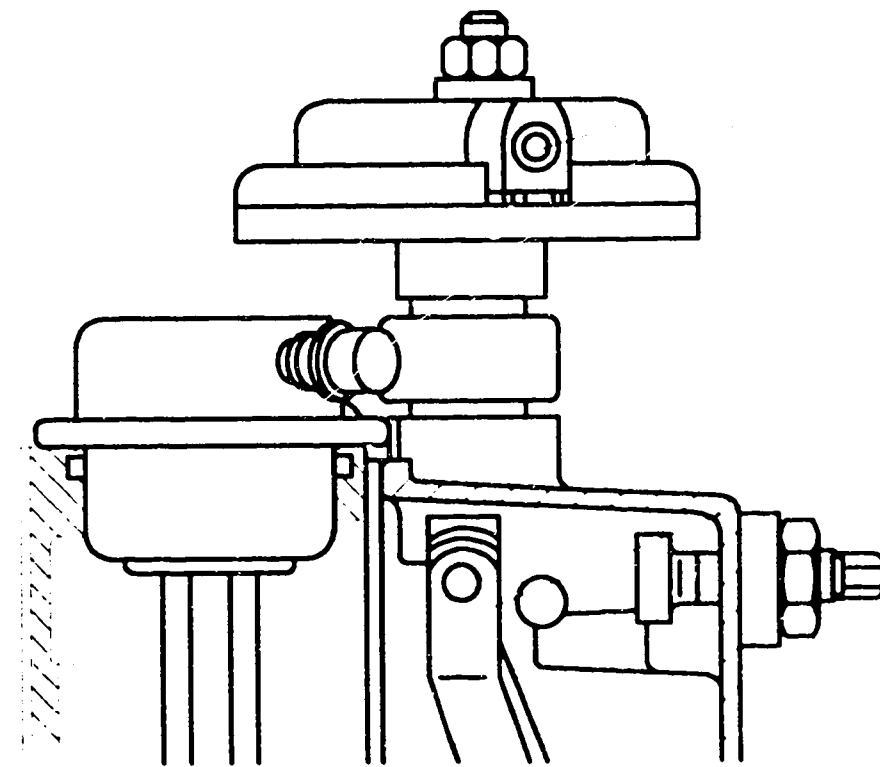

KMK00992

1 = Correction linkage
2 = Connection for connecting line to engine intake manifold (acquisition of absolute pressure)

CHECKING ALDA ADJUSTMENT
* Section "Measurement"

Determine required pressure.
If reduction in control-rod travel is not within stated tolerance, replace ALDA aneroid box.

Repeat measurement.

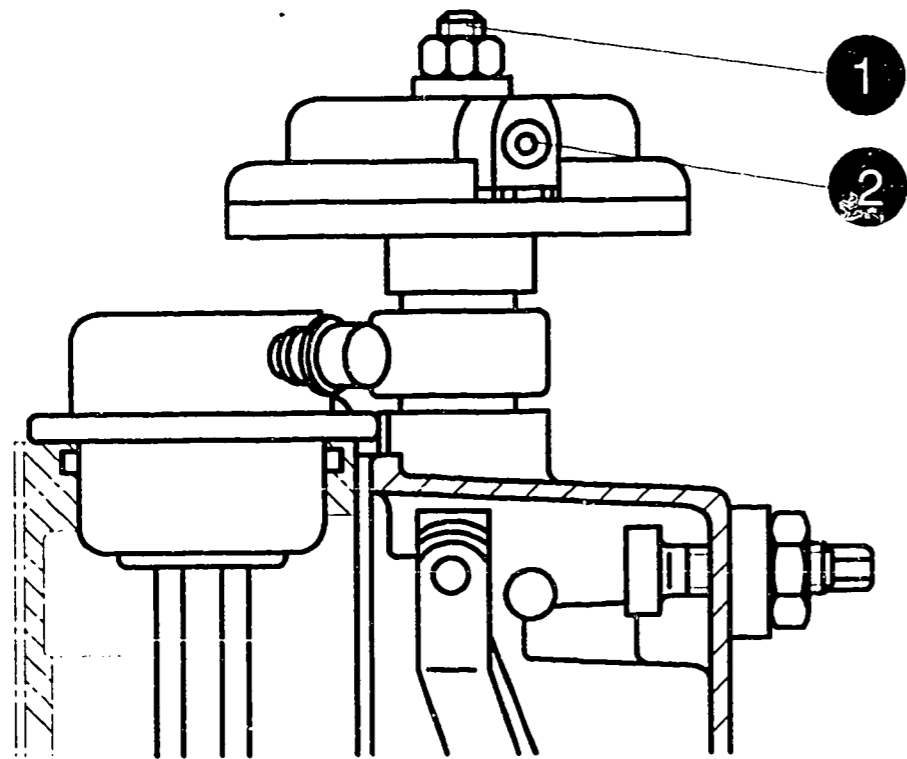

KMK00993

- 1 = Adjusting screw
- 2 = Connection for connecting line to engine intake manifold (acquisition of absolute pressure)

CHECKING DELIVERY WITH BOOST PRESSURE

* Section "Fuel-delivery characteristics"

Operate fuel-injection pump at appropriate speed.
Position control lever against full-load stop.

Apply calculated differential pressure or absolute pressure to ALDA aneroid box.

Correct injected quantity at adjusting screw of ALDA aneroid box.

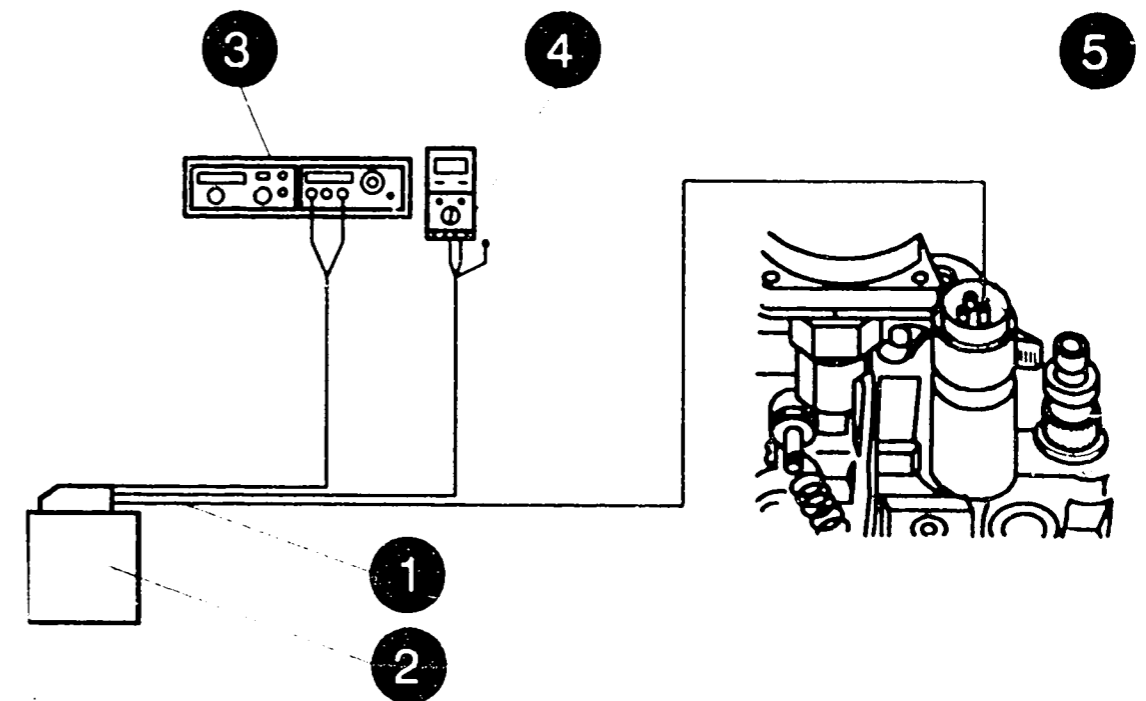

KMK00994

- 1 = Test line KDEP-P400/2 with system adapter lead KDEP-P400/4
- 2 = Evaluation circuit R5-1.2
- 3 = Regulator 13.5 V/0.5/3 A (or battery)
Connector: red (+), black (-)
- 4 = Digital voltmeter 0..5 V
Connectors: red = reference voltage
green = output voltage
blue = measurement ground
- 5 = Connection: plug, 3-pole

ADJUSTING RACK POSITION SENSOR

* Connection diagram

Connect up test and supply components to test line and system adapter lead in accordance with connection diagram and labeled legend.

Attach connector, 3-pole of system adapter lead KDEP-P400/4 to plug housing of pump.
Attach connector, red (+), black (-) (direct lead to 25-pole plug) to regulator.
Switch on regulator and set 13.5 volts.

Voltmeter:

* Connection (3-core lead) for testing U/Ref. (reference voltage of test control unit/supply voltage of rack position sensor): red (+), blue (-).
Desired reading: 4.99...5.01 V.
Incorrect value: tester defective.

* Connection for all other tests (U/Stan.): green (+), blue (-).

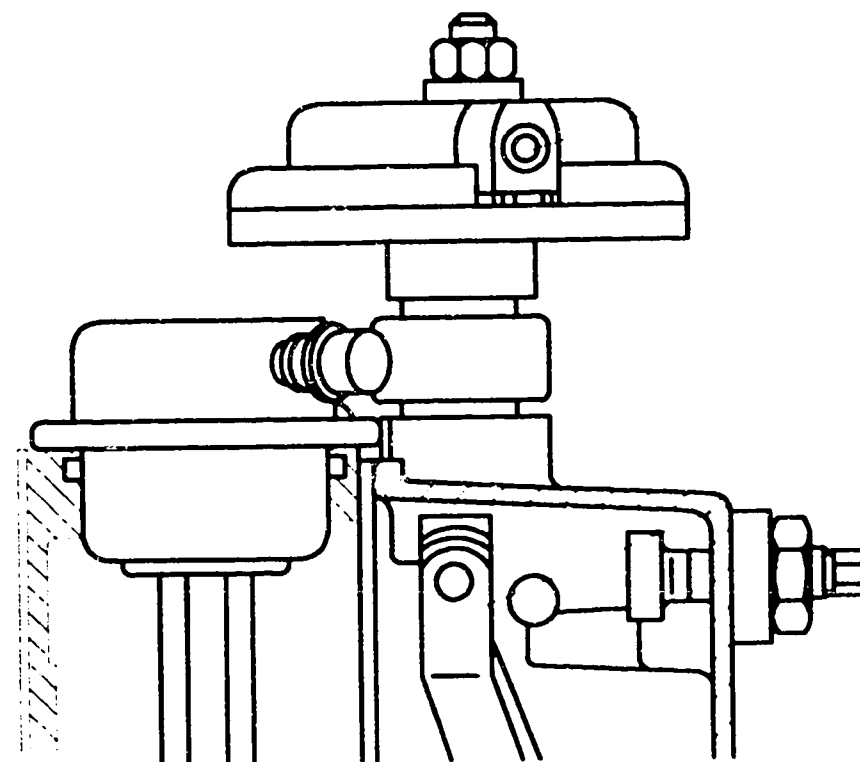

KMK00992

2 = Connection for connecting line to engine intake manifold (acquisition of absolute pressure)

* Connection for all other tests
U/Stan.: green (+)
blue (-)

Note:

U/Stan. is the voltage calculated by the test control unit from the rack-position-sensor signal and is thus a measure of the control-rod travel.

Position control lever against full-load stop.
Apply calculated differential pressure to ALDA aneroid box at connection.

Differential pressure = absolute pressure as per test-specification sheet - atmospheric pressure.

* Rack-position-sensor incoming inspection
(refer to test-specification sheet for "Check value")

Position control lever against full-load stop.
Operate fuel-injection pump at speed as per test-specification sheet.
Set 13.5 V at regulator.
If provided, apply absolute pressure or differential pressure to ALDA aneroid box.
Read off voltage value from digital multimeter.

If voltage value as per test-specification sheet is not obtained, adjust rack position sensor.

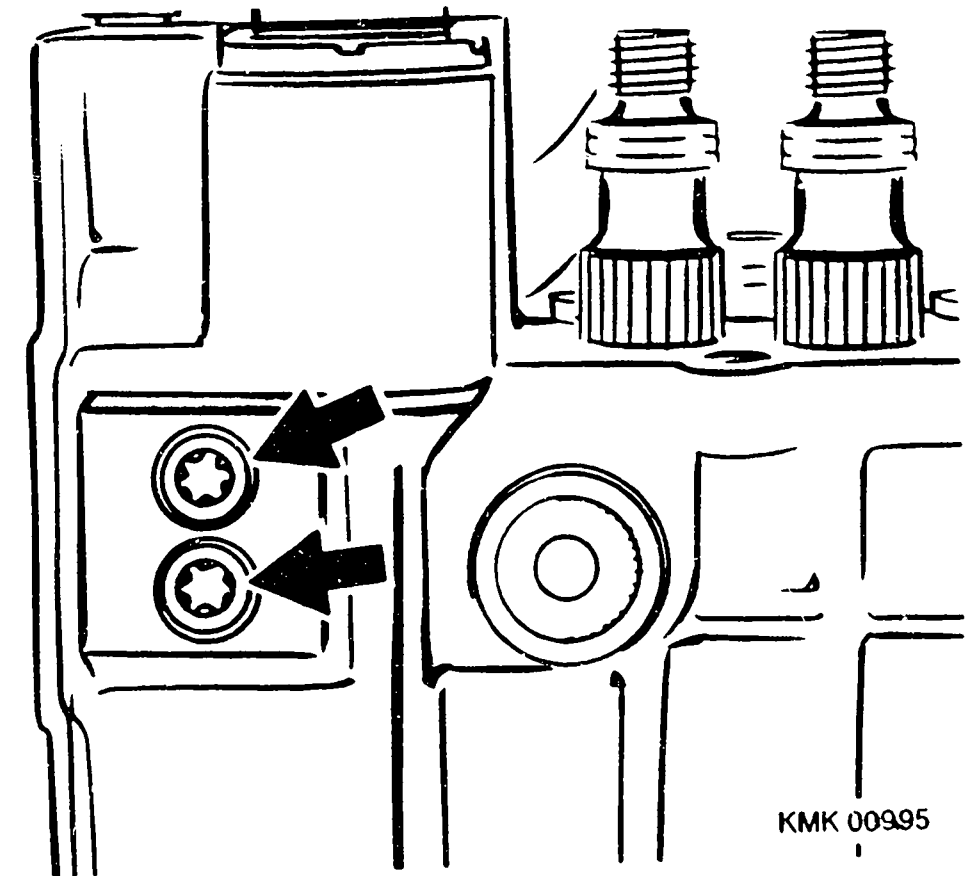

Arrows = Rack-position-sensor fastening screws

* Adjusting rack position sensor
("Setting" as per test-specification sheet):

Operate fuel-injection pump at speed as per test-specification sheet.
Use control lever to set delivery in accordance with test-specification sheet.
Voltage value must be attained in this process.

If set value is not attained, loosen fastening screws of rack position sensor.
Move rack position sensor until set value is indicated.
Position control lever against full-load stop.
Check voltage value.

Install shutoff unit and check function.
Completely assemble fuel-injection pump and detach from test bench.
Use test cone KDEP 1565 to check for leaks in camshaft chamber. Fit lead seal on pump.

TABLE OF CONTENTS

Section	Coordinate
Structure of microcard	A01
Special features/test specifications	A02
Tightening torques	A03
Governor map	A07
Instructions on testing governors	A09
Safety precautions	A11
Test conditions	A13
Test set-up	A14
Tools and test equipment	A16
Exploded views	A19
 Trouble-shooting chart for partial repair	 B01
* Checking position of control sleeves	B03
* Renewing shutoff stop screw	B04
* Checking shorting ring of rack position sensor for freedom of movement	B05
* Checking vacuum unit	B06
* Checking pneumatic idle increase (PLA)	B07
* Renewing idle auxiliary spring	B08
* Checking idle-quantity scatter	B10
* Renewing flyweight	B11

ADJUSTING RSF GOVERNOR WITH NO START-OF-DELIVERY
SENSOR SYSTEM

Preparation	B12
Governor presettings	B14
Adjusting control-rod-travel measuring device	B16
Static idle-stage adjustment	B17
Dynamic idle-stage adjustment	B18
 Adjusting full-load control-rod travel and measuring delivery	 B20
Adjusting full-load speed regulation	B21
Checking high idle	B22
Checking position of sliding sleeve	B24
Checking torque-control profile	B25
Starting control-rod travel and starting fuel delivery	B26
 Adjusting position of idle control lever	 B27

TABLE OF CONTENTS

Section	Coordinate
Adjusting idle control-rod travel	B28
Adjusting idle auxiliary spring	C01
Checking load take-up	C02
Idle auxiliary spring shutoff	C03
 Checking adjustment of idle auxiliary spring shutoff	 C05
 Correcting idle-auxiliary spring shutoff.....	 C07
 Fitting governor cover	 C09
Fitting vacuum control valve	C10
Concluding work	C12
 Checking fuel-injection pump for leaks	 C14

TABLE OF CONTENTS

Section	Coordinate
CHECKING RSFII GOVERNOR WITH START-OF-DELIVERY SENSOR SYSTEM	
Preparation	C15
Governor presettings	C18
Attaching control-rod-travel measuring device	C20
Static idle-stage adjustment	C21
Dynamic idle-stage adjustment	
* Vehicle with no two-mass flywheel	C22
* Vehicle with two-mass flywheel	C24
Adjusting full-load control-rod travel and measuring delivery	C26
Adjusting full-load speed regulation	C28
Setting high idle	D01
Checking position of sliding sleeve	D03
Checking torque-control profile	D04
Start. control-rod travel and start. fuel delivery..	D05
Adjusting position of idle control lever	D06
Adjusting idle control-rod travel.....	D07
Adjusting idle auxiliary spring	D09
Checking load take-up	D10
Idle auxiliary spring shutoff	D11
Check./correct. setting of idle aux. spring shutoff	D13
Installation of governor cover	D17
Attaching housing for servo magnet (ARD)	D18
Calibrating servo magnet	D19
Attaching servo magnet of idle-speed regulation	D22
Attach. and test. add-on modules/table of contents .	E28

TABLE OF CONTENTS

Section	Coordinate
ADJUSTING GOVERNOR RSFII WITH POSITIVE/NEGATIVE TORQUE CONTROL	
	D24
Governor presettings	E03
Attaching control-rod-travel measuring device	E05
Static idle-stage adjustment	E06
Dynamic idle-stage adjustment:	
* Vehicle with no two-mass flywheel	E07
* Vehicle with two-mass flywheel	E09
Adjusting full-load control-rod travel and measuring delivery	E11
Adjusting position of idle control lever	E12
Measuring idle control-rod travel and delivery	E13
Adjusting idle auxiliary spring	E15
Checking load take-up	E16
Adjusting idle auxiliary spring shutoff	E17
Adjusting full-load speed regulation	E18
Checking high idle	E19
Checking position of sliding sleeve	E21
Checking torque-control profile	E22
Measuring starting control-rod travel and delivery	E25
Concluding work	E27
Attaching and testing add-on modules	E28

TABLE OF CONTENTS

Section	Coordinate
ATTACHING AND TESTING ADD-ON MODULES	
Tools and test equipment	F01
Ambient-pressure-dependent	
full-load stop (ADA)	F03
* Checking pin projection	F03
* Adjusting pin projection	F04
Determining adjustment pressure	F05
Test connections	F06
Setting ADA adjustment	F07
Absolute boost pressure-dependent	
full-load stop (ALDA)	F09
* Checking pin projection	F09
* Adjusting pin projection	F10
Determining ambient pressure	F11
Laying of lines to ALDA unit	F12
ALDA adjustment test, setting/checking	F13
Measuring delivery with boost pressure	F15
Adjusting rack position sensor	F16

PUBLICATION INFORMATION

(c) 1996 ROBERT BOSCH GmbH Automotive Equipment -
 After-Sales Service, Department of Technical
 Publications KH/VDT, Postfach 30 02 20,
 D-70442 Stuttgart.
 Published by: After-Sales Service Department for Training
 and Technology (KH/VSK).
 Press date 03.1996.
 Please direct questions and comments concerning the
 contents to our authorized representative in your country.
 This publication is only for the use of the Bosch After-
 Sales Service Organization and may not be passed on to
 third parties.

Microfilmed in the Federal Republic of Germany.
 Microphotographié en République Fédérale d'Allemagne.